

S70



IO-Link

ADVANCED FIBER OPTIC AMPLIFIERS FOR HIGH SPEED AND LOW CONTRAST APPLICATIONS

- DIN rail mounting
- Double digital display
- High Speed models: 200 μ s ... 5 ms
- Super High Speed models: 10 μ s ... 1ms
- Teach-in setting via switch / button + / SET / -,
- Remote input
- IO-Link communication V1.1 COM2 2,3ms cycle time
- High level of parameterization
- Normalized connection with 2 m or 4-pole M8 cable



APPLICATIONS

- Processing and Packaging machinery
- Electronics assembling
- Pharmaceutical industry
- Cosmetic and bottling industries

S70

Response time		Super high speed: 10 μ s (S70...E2) High speed: 200 μ s (S70...E1), 15 μ s (S70...E2), 250 μ s (S70...E3) Fast: 50 μ s (S70...E2), 500 μ s (S70...E3) Standard: 500 μ s (S70...E1), 250 μ s (S70...E2), 1 ms (S70...E3) Medium range: 500 μ s (S70...E2) Long range: 2 ms (S70...E1), 1 ms (S70...E2), 4 ms (S70...E3) Extra long range: 5 ms (S70...E1), 12 ms (S70...E3)
	Repeatability	Super high speed: 5 μ s (S70...E2) High speed: 66 μ s (S70...E1), 5 μ s (S70...E2), 100 μ s (S70...E3) Fast: 12 μ s (S70...E2), 150 μ s (S70...E3) Standard: 100 μ s (S70...E1), 50 μ s (S70...E2), 180 μ s (S70...E3) Medium range: 80 μ s (S70...E2) Long range: 100 μ s (S70...E1), 165 μ s (S70...E2), 180 μ s (S70...E3) Extra long range: 100 μ s (S70...E1), 180 μ s (S70...E3)
Power supply	Vdc	10...30 V (current output models and digital output models) 12...30 (voltage output models) 18...30 V (mod. IO-Link mod. IO-Link -PZ)
	Vac	
	Vac/dc	
Output	PNP	•
	NPN	•
	NPN/PNP	
	relay	
	other	Analog out 4...20mA; Analog out 0...10V; Analog out 0...5V IO-Link V1.1 COM2 2,3ms cycle time (only model -PZ)
Connection	cable	•
	connector	•
	pig-tail	
Approximate dimensions (mm)		10x79x31.5
Housing material		ABS and polycarbonate
Mechanical protection		IP50, NEMA 1

TECHNICAL DATA

Power supply	10...30 V (current output models and digital output models) 12...30 (voltage output models)
Ripple	10% max.
Consumption (output current excluded)	40 mA max. (standard display mode), 30 mA max. (ECO display mode)
Light emission	red 660 nm (mod. S70...E1, S70...E3) red 635 nm (mod. S70...E2)
Setting	+ / SET / - push-button, LIGHT / DARK switch, RUN / PRG / ADJ mode switch yellow OUTPUT LED
Indicators	red SIGNAL LEVEL 4-digit display green THRESHOLD 4-digit display
Output	PNP or NPN PNP and push-pull (IO-Link mod. S70...PZ)
Output current	100 mA max.
Saturation voltage	1,5 V max. (mod. S70...N) 2 V max. (mod. S70...P/PZ)
Response time	Super high speed: 10 µs (S70...E2) High speed: 200 µs (S70...E1), 15 µs (S70...E2), 250 µs (S70...E3) Fast: 50 µs (S70...E2), 500 µs (S70...E3) Standard: 500 µs (S70...E1), 250 µs (S70...E2), 1 ms (S70...E3) Medium range: 500 µs (S70...E2) Long range: 2 ms (S70...E1), 1 ms (S70...E2), 4 ms (S70...E3) Extra long range: 5 ms (S70...E1), 12 ms (S70...E3)
Switching frequency	S70...E1: 2,5 kHz (High Speed), 1 kHz (Standard), 250 Hz (Long Range), 100 Hz (Extra Long Range) S70...E2: 50 kHz (Super High Speed), 33 kHz (High Speed), 10 kHz (Fast), 2 kHz (Standard), 1 kHz (Medium Range), 500 Hz (Long Range) S70...E3: 1 kHz (High Speed), 500 Hz (Fast), 250 Hz (Standard), 62,5 Hz (Long Range), 20 Hz (Extra Long Range)
IO-Link interface	baud rate: 38400 bps (COM2) process data width: 16 bits IODD files: provide all programming options of top panel interface, plus additional functionality 2,3ms cycle time V1.1.2 Smart Sensor Profile
Connection	2 m cable, M8 4-pole connector
Dielectric strength	500 Vac, 1 min between electronics and housing
Insulating resistance	>20 MΩ, 500 Vdc between electronics and housing
Electrical protection	class 2
Mechanical protection	IP50, NEMA 1
Ambient light rejection	according to EN 60947-5-2
Vibrations	0,5 mm amplitude, 10 ... 55 Hz frequency, for every axis (EN60068-2-6)
Shock resistance	11 ms (30 G) 6 shock for every axis (EN60068-2-27)
Housing material	ABS and polycarbonate
Operating temperature	-10 ... 55 °C
Storage temperature	-25 ... 85 °C
Weight	69 g max. cable vers., 21 g max. conn. vers.

DIMENSIONS

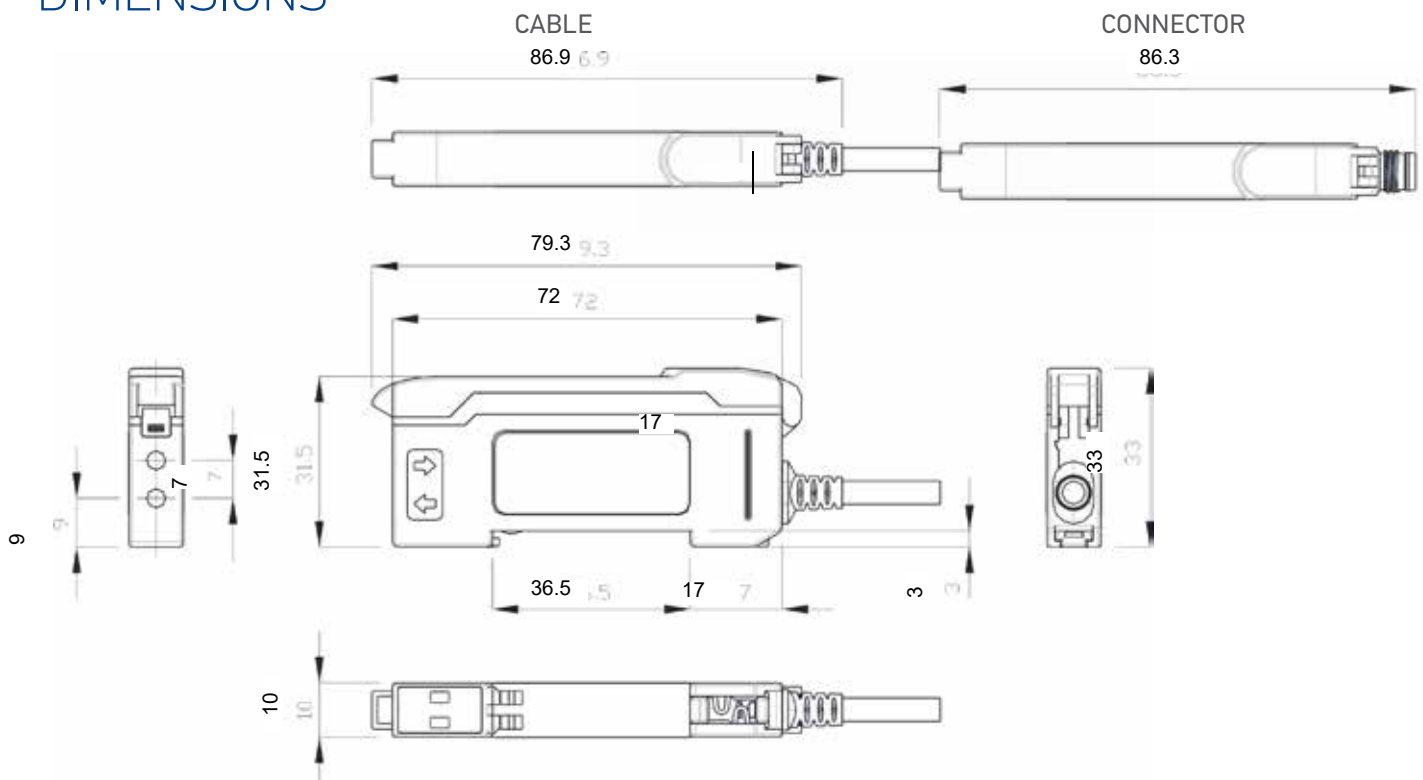

CONNECTIONS

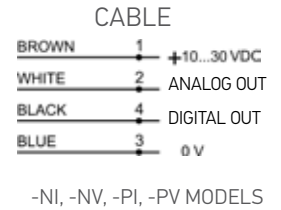
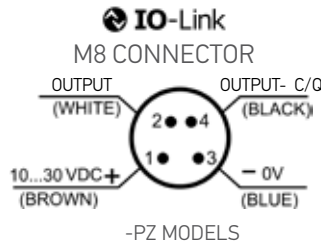
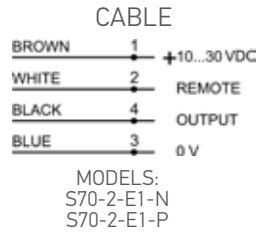
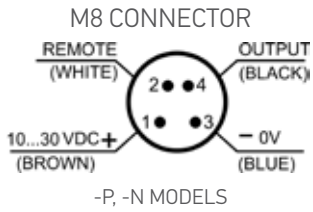

INDICATOR AND SETTINGS

The **RUN/PRG/ADJ Mode Switch** puts the sensor in RUN, PRG (Program), or ADJ (Adjust) mode. RUN mode allows the sensor to operate normally and prevents unintentional programming changes via the **+ /SET/ -** button. PRG mode allows the sensor to be programmed through the display driven programming menu. ADJ mode allows the user to perform TEACH and SET methods and Manual Adjust.

The **LO/DO Switch** is used to select Light Operate or Dark Operate mode.

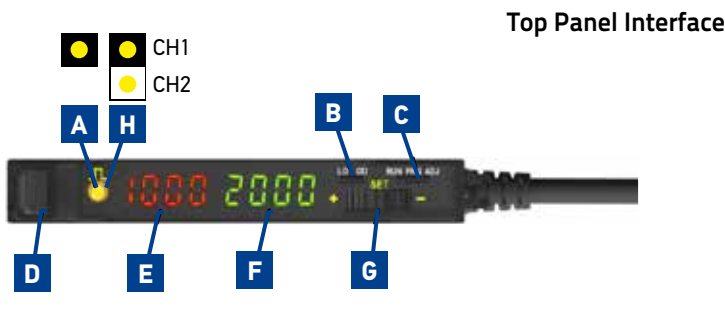

- A Output LED
- B LO/DO Switch
- C RUN/PRG/ADJ
- D Lever Action Fiber Clamp
- E Red Signal Level
- F Green Threshold
- G +/SET/- Rocker Button
- H CH1 Analog out, CH2 Discrete out (only S70...E3)

As an alternative the sensor can be programmed remotely and the remote input may be used to perform TEACH and SET methods (not available on IO-Link models).

DETECTION DIAGRAMS

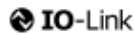

	S70-E1			
	HIGH SPEED	STANDARD	LONG RANGE	EXTRA LONG RANGE
Response Time	200 μ s	500 μ s	2 ms	5 ms
Repeatability	66 μ s	100 μ s	100 μ s	100 μ s

EXCESS GAIN

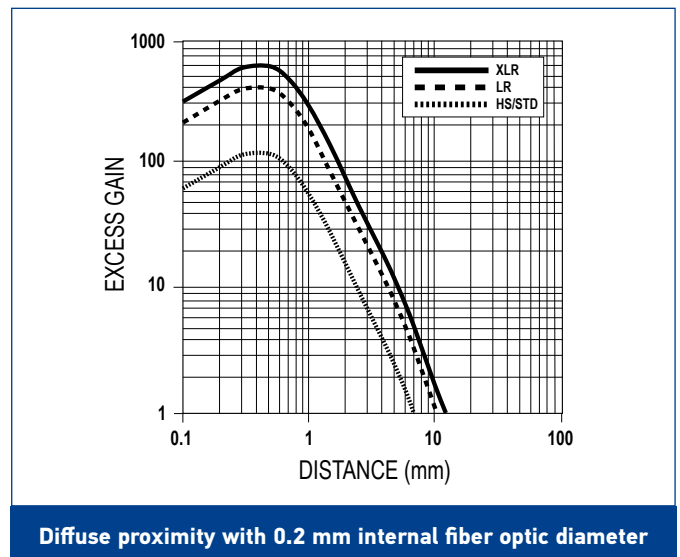
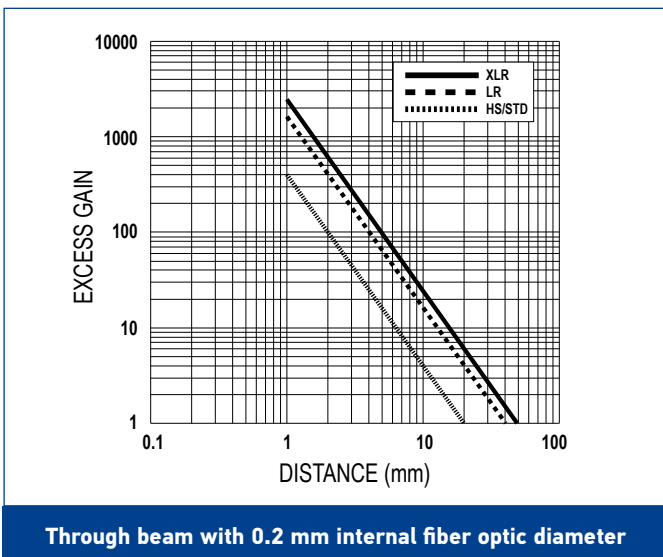

EXCESS GAIN

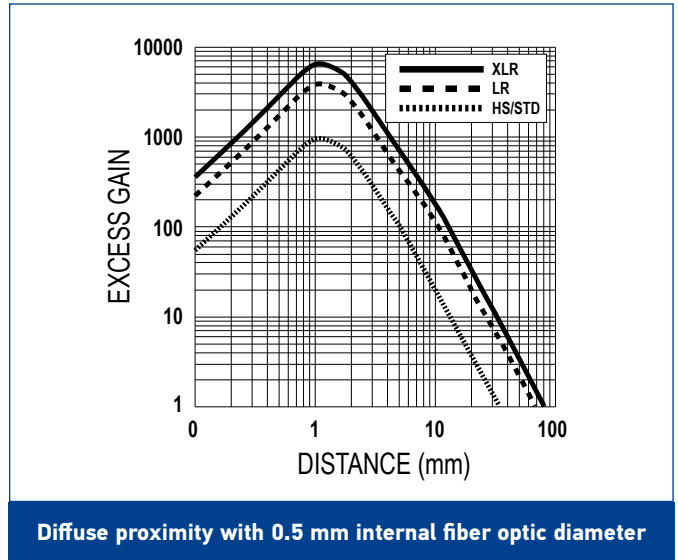
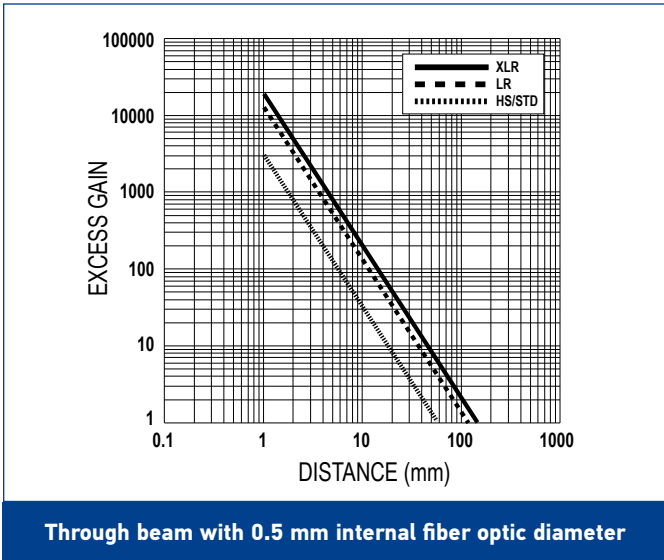

EXCESS GAIN

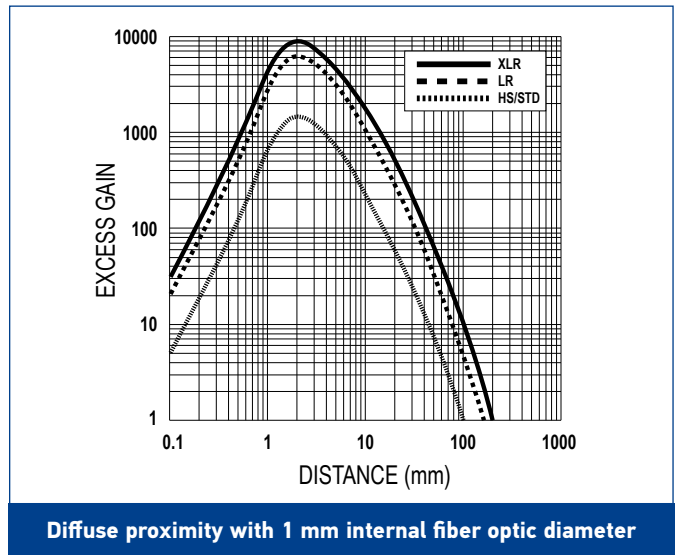
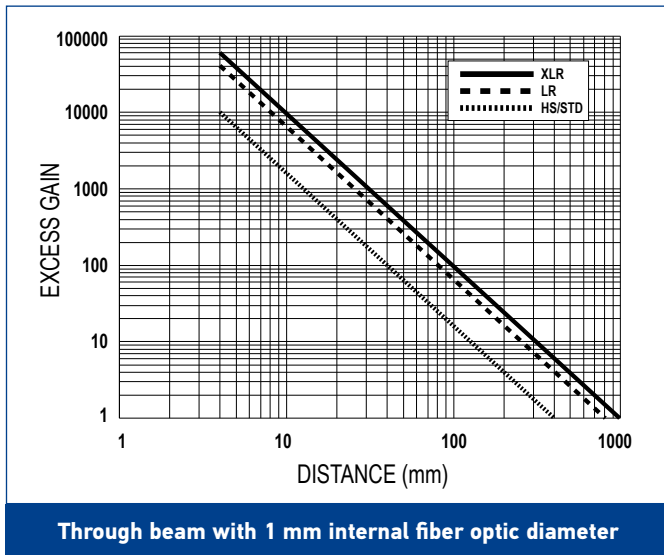

EXCESS GAIN

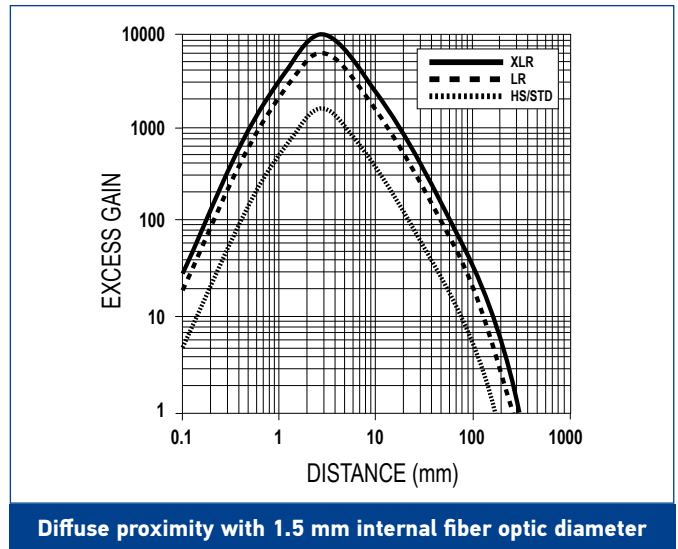
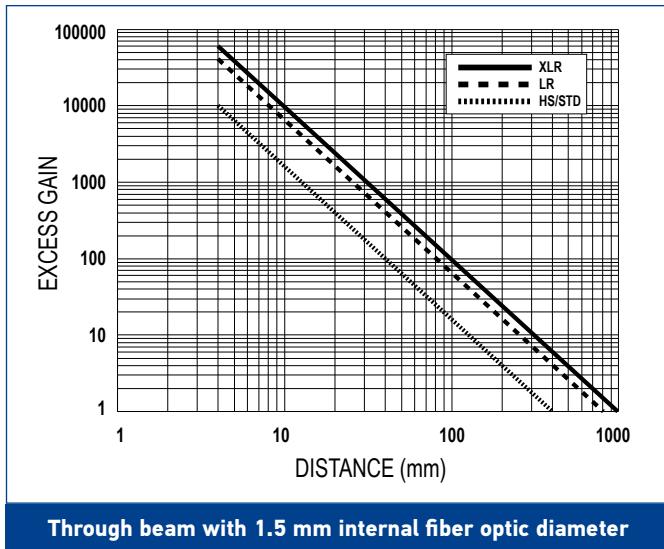

S70-E1

	HIGH SPEED	STANDARD	LONG RANGE	EXTRA LONG RANGE
Response Time	200 μ s	500 μ s	2 ms	5 ms
Repeatability	66 μ s	100 μ s	100 μ s	100 μ s

DETECTION AREA

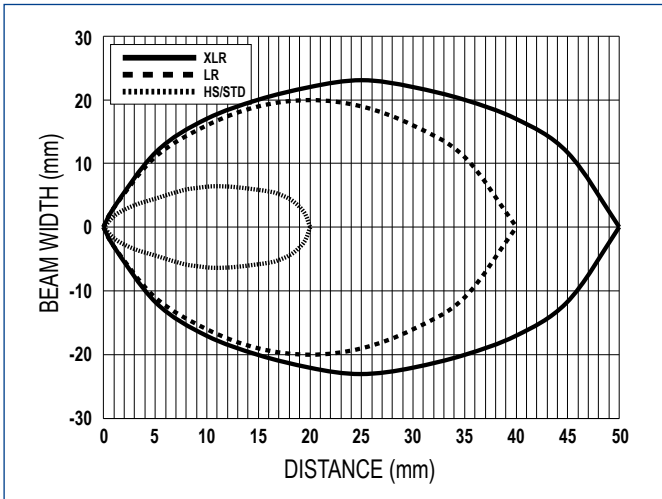

Through beam with 0.2 mm internal fiber optic diameter

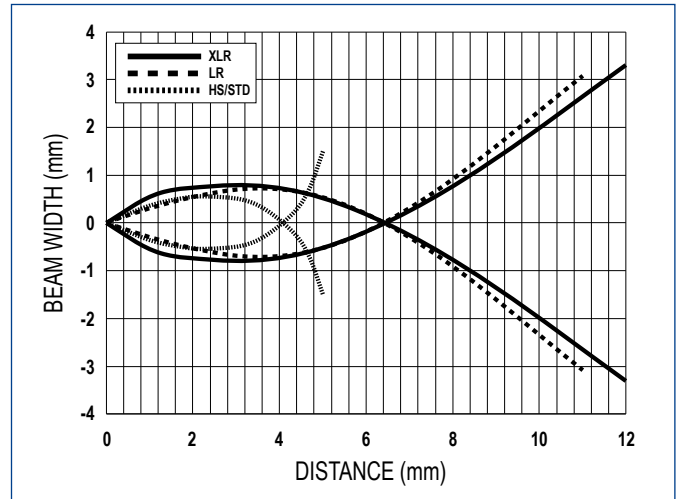

Diffuse proximity with 0.2 mm internal fiber optic diameter

DETECTION AREA

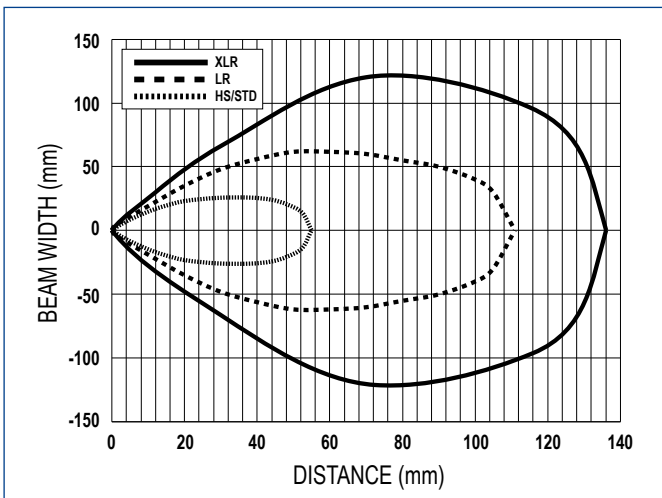

Through beam with 0.5 mm internal fiber optic diameter

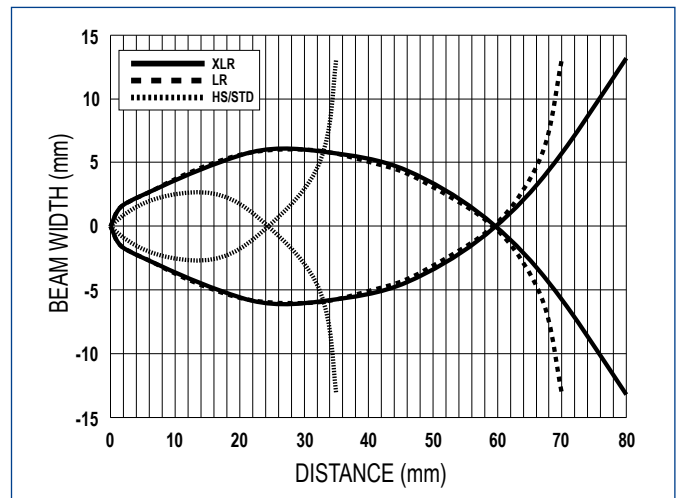

Diffuse proximity with 0.5 mm internal fiber optic diameter

S70-E1

	HIGH SPEED	STANDARD	LONG RANGE	EXTRA LONG RANGE
Response Time	200 μ s	500 μ s	2 ms	5 ms
Repeatability	66 μ s	100 μ s	100 μ s	100 μ s

DETECTION AREA

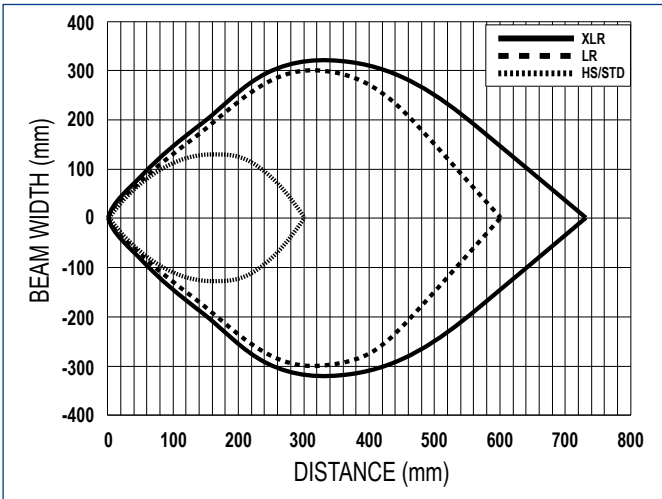

Through beam with 1 mm internal fiber optic diameter

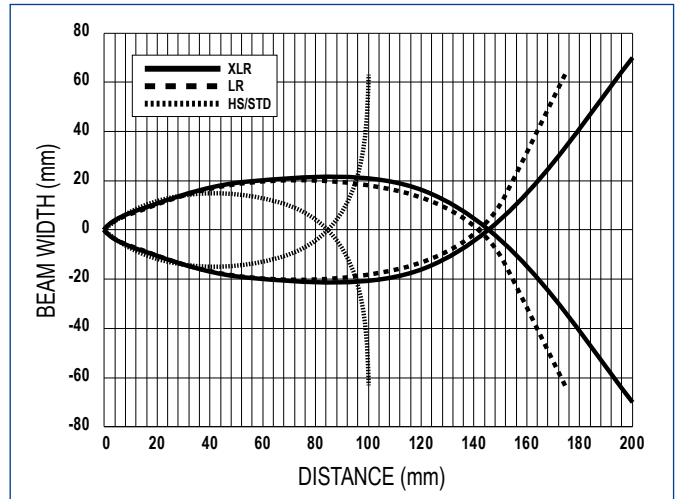

Diffuse proximity with 1 mm internal fiber optic diameter

DETECTION AREA

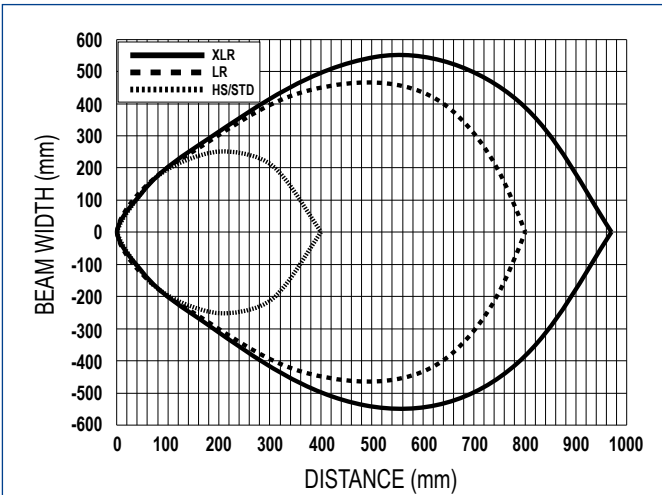

Through beam with 1.5 mm internal fiber optic diameter

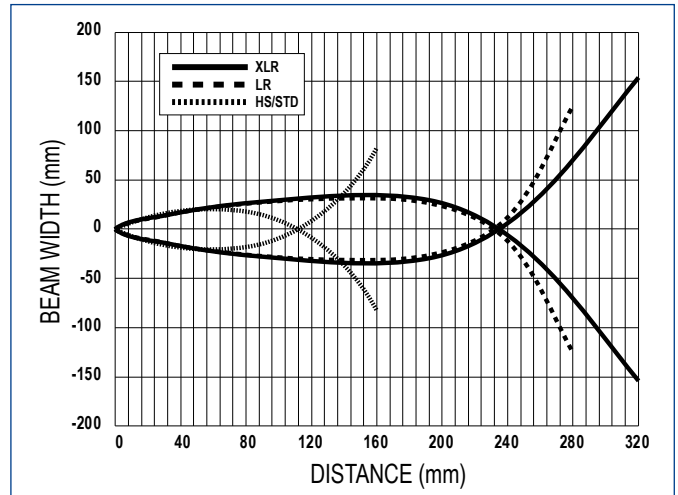

Diffuse proximity with 1.5 mm internal fiber optic diameter

S70-E2

	SUPER HIGH SPEED	HIGH SPEED	FAST	STANDARD	MEDIUM RANGE	LONG RANGE
Response Time	10 μ s	15 μ s	50 μ s	250 μ s	500 μ s	1 ms
Repeatability	5 μ s	5 μ s	12 μ s	50 μ s	80 μ s	165 μ s

EXCESS GAIN

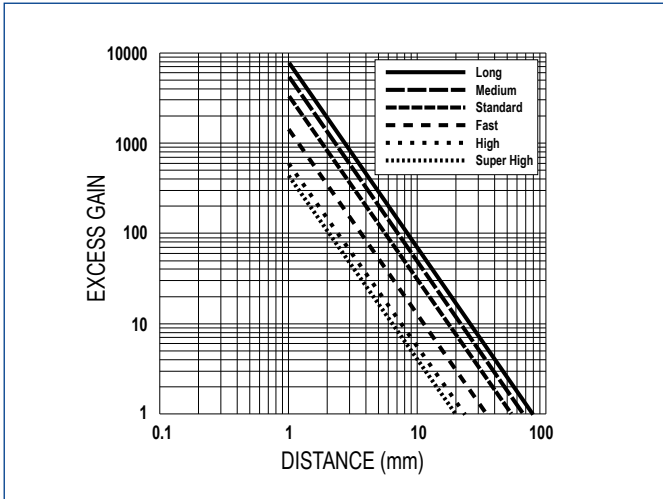

Through beam with 0.2 mm internal fiber optic diameter

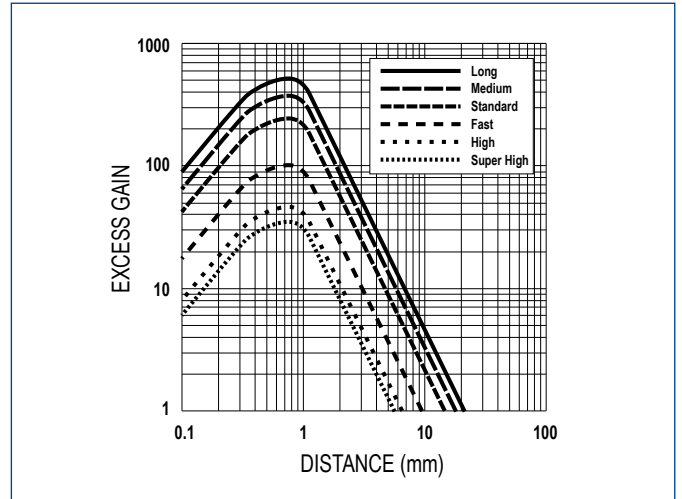

Diffuse proximity with 0.2 mm internal fiber optic diameter

EXCESS GAIN

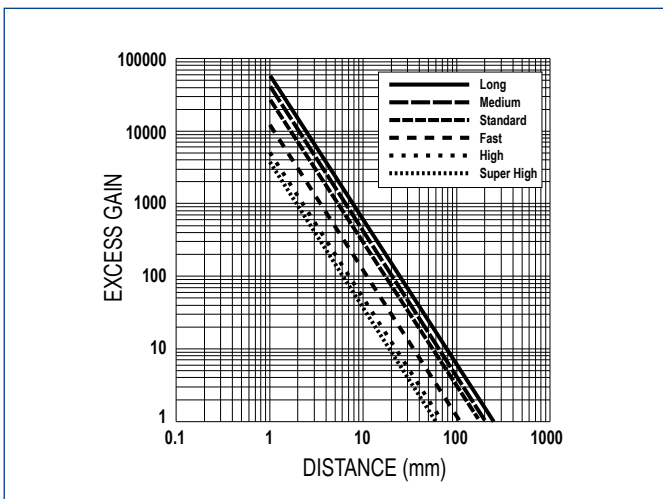

Through beam with 0.5 mm internal fiber optic diameter

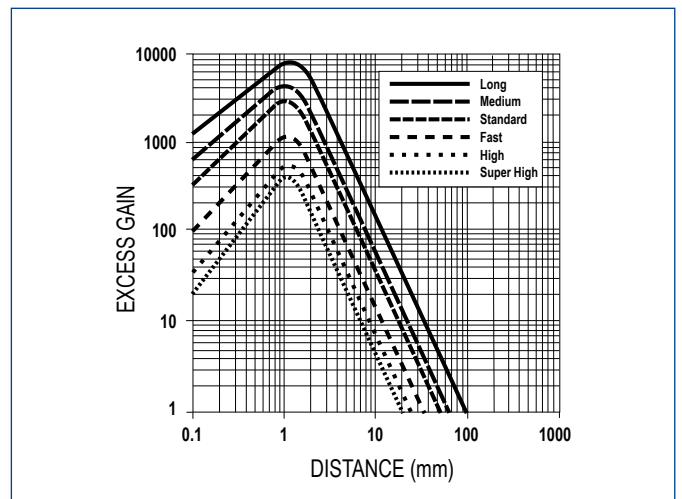

Diffuse proximity with 0.5 mm internal fiber optic diameter

S70-E2

	SUPER HIGH SPEED	HIGH SPEED	FAST	STANDARD	MEDIUM RANGE	LONG RANGE
Response Time	10 μ s	15 μ s	50 μ s	250 μ s	500 μ s	1 ms
Repeatability	5 μ s	5 μ s	12 μ s	50 μ s	80 μ s	165 μ s

EXCESS GAIN

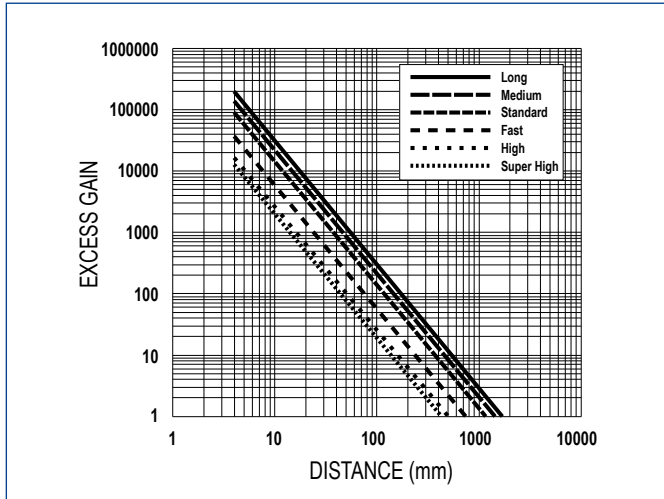

Through beam with 1 mm internal fiber optic diameter

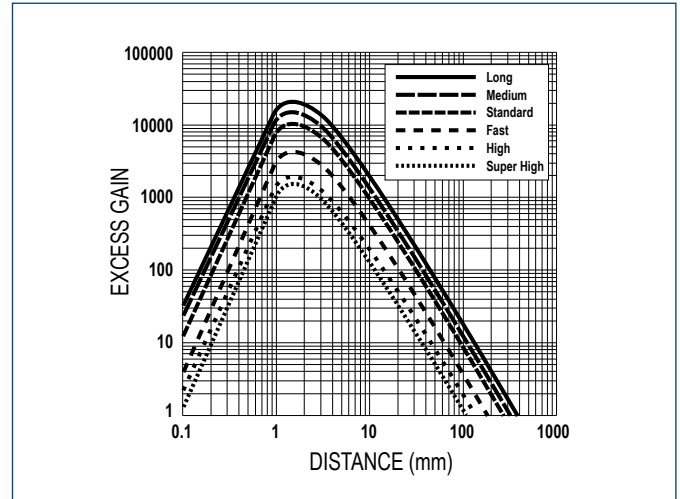

Diffuse proximity with 1 mm internal fiber optic diameter

EXCESS GAIN

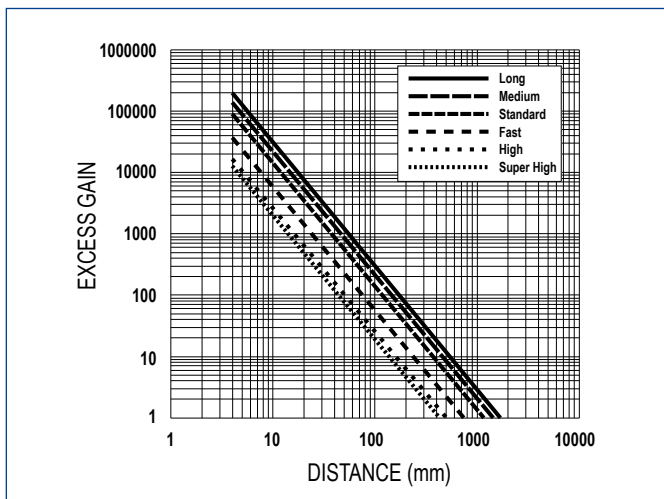

Through beam with 1.5 mm internal fiber optic diameter

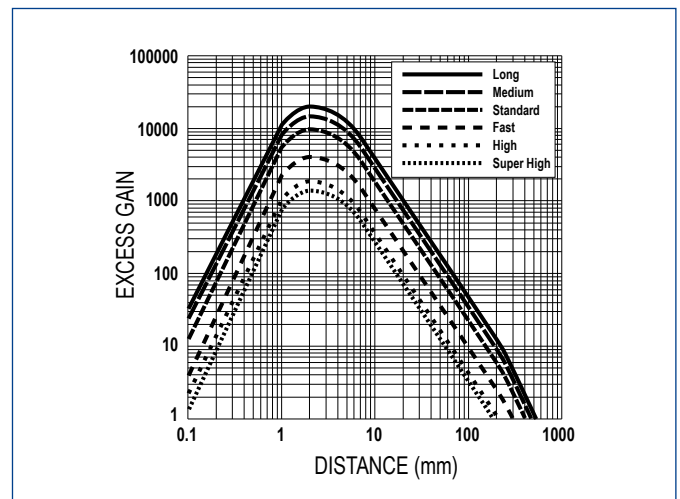

Diffuse proximity with 1.5 mm internal fiber optic diameter

S70-E2

	SUPER HIGH SPEED	HIGH SPEED	FAST	STANDARD	MEDIUM RANGE	LONG RANGE
Response Time	10 μ s	15 μ s	50 μ s	250 μ s	500 μ s	1 ms
Repeatability	5 μ s	5 μ s	12 μ s	50 μ s	80 μ s	165 μ s

DETECTION AREA

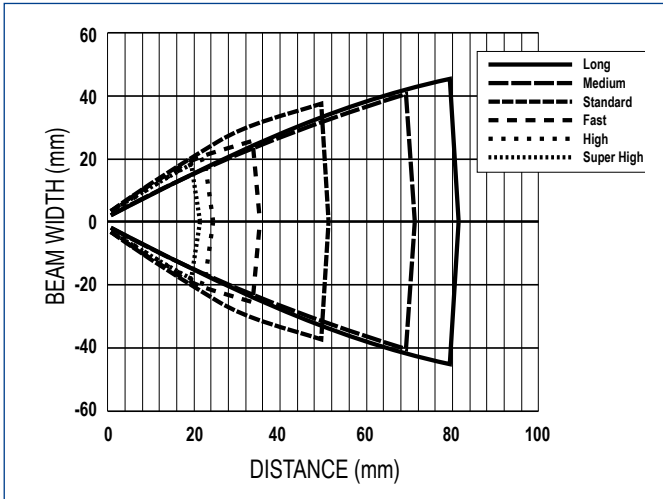

Through beam with 0.2 mm internal fiber optic diameter

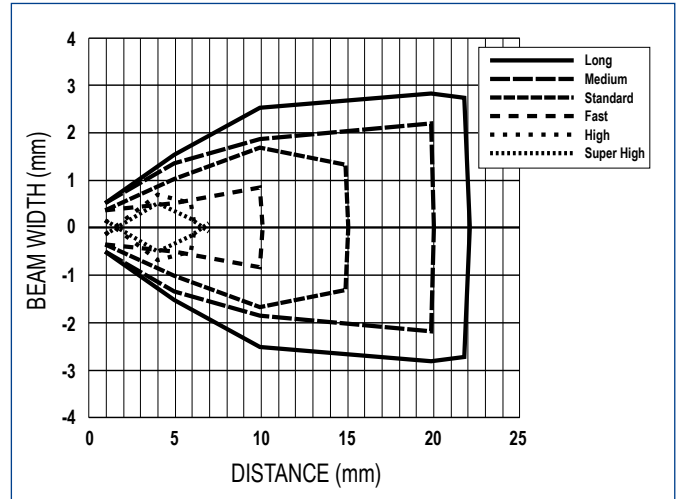

Diffuse proximity with 0.2 mm internal fiber optic diameter

DETECTION AREA

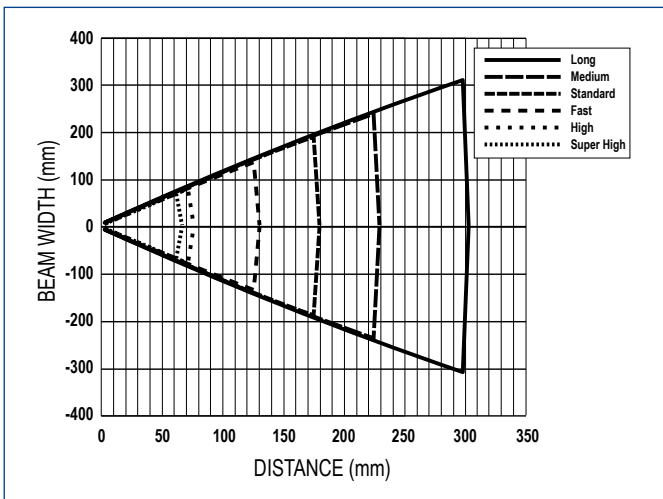

Through beam with 0.5 mm internal fiber optic diameter

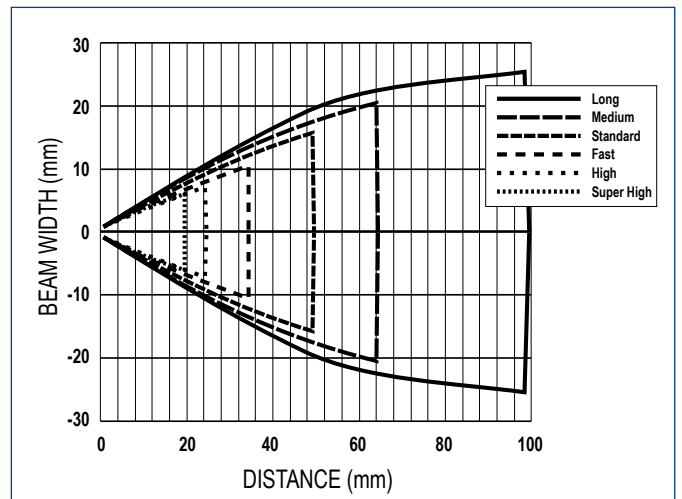

Diffuse proximity with 0.5 mm internal fiber optic diameter

S70-E2

	SUPER HIGH SPEED	HIGH SPEED	FAST	STANDARD	MEDIUM RANGE	LONG RANGE
Response Time	10 μ s	15 μ s	50 μ s	250 μ s	500 μ s	1 ms
Repeatability	5 μ s	5 μ s	12 μ s	50 μ s	80 μ s	165 μ s

DETECTION AREA

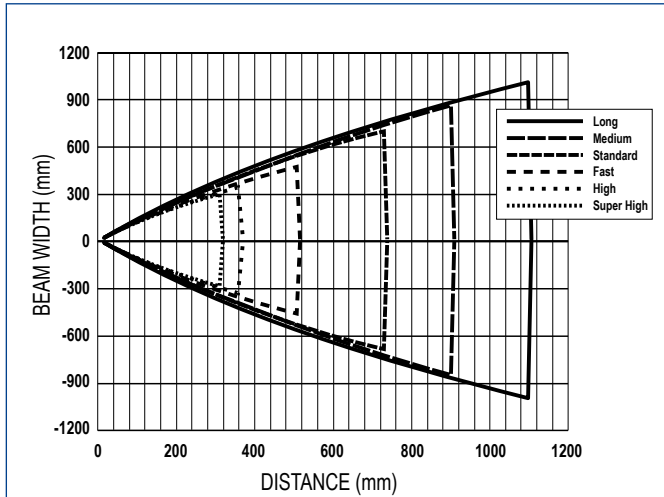

Through beam with 1 mm internal fiber optic diameter

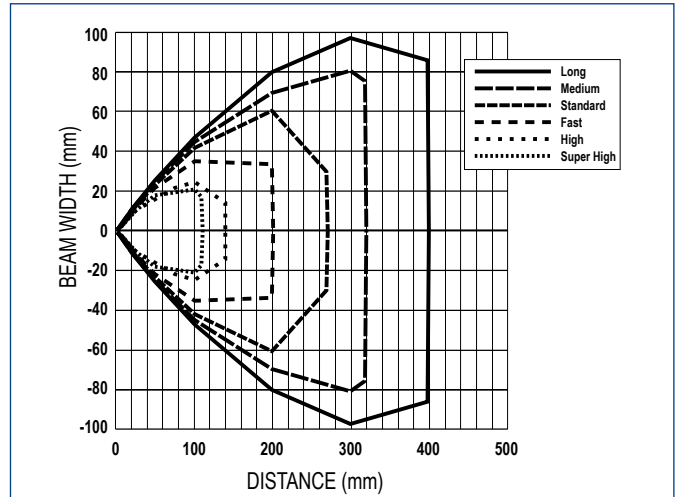

Diffuse proximity with 1 mm internal fiber optic diameter

DETECTION AREA

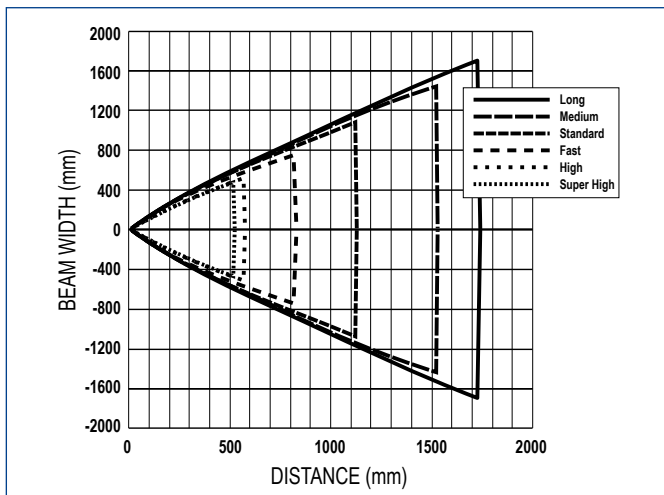

Through beam with 1.5 mm internal fiber optic diameter

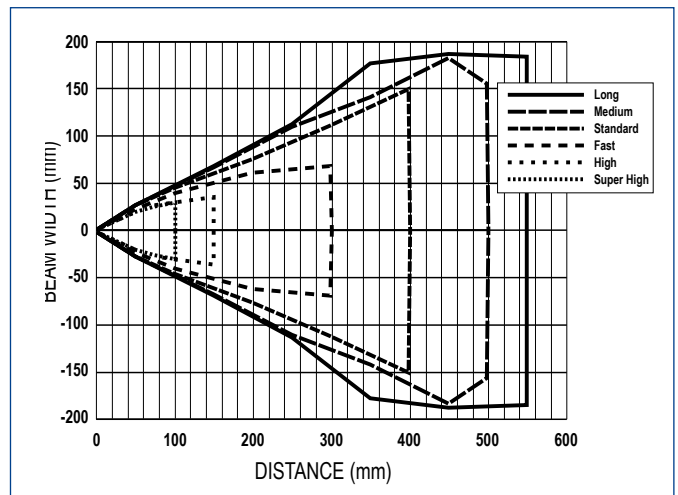

Diffuse proximity with 1.5 mm internal fiber optic diameter

S70-E3

	SUPER HIGH SPEED	HIGH SPEED	FAST	STANDARD	LONG RANGE	EXTRA LONG RANGE
Response Time	-	250 μ s	500 μ s	1 ms	4 ms	12 ms
Repeatability	-	100 μ s	150 μ s	180 μ s	180 μ s	180 μ s

EXCESS GAIN

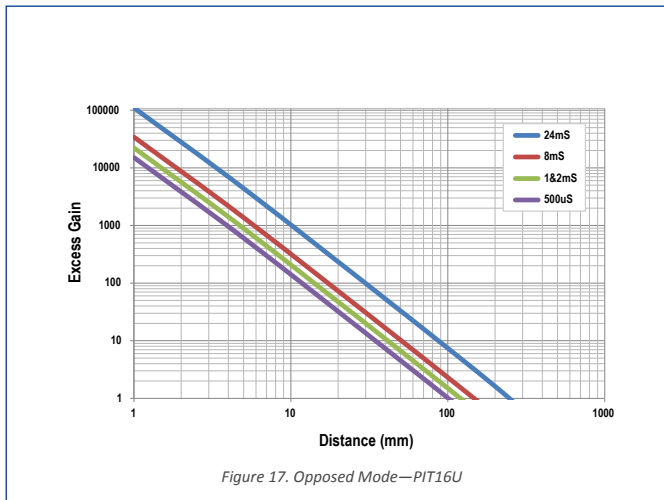

Through beam with 0.2 mm internal fiber optic diameter

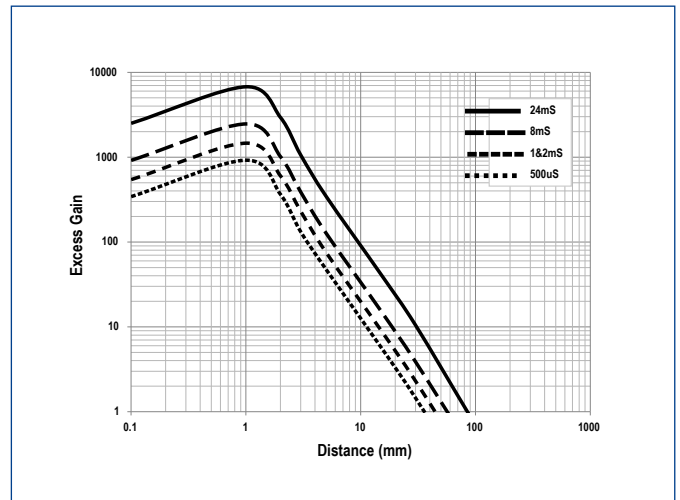

Diffuse proximity with 0.2 mm internal fiber optic diameter

EXCESS GAIN

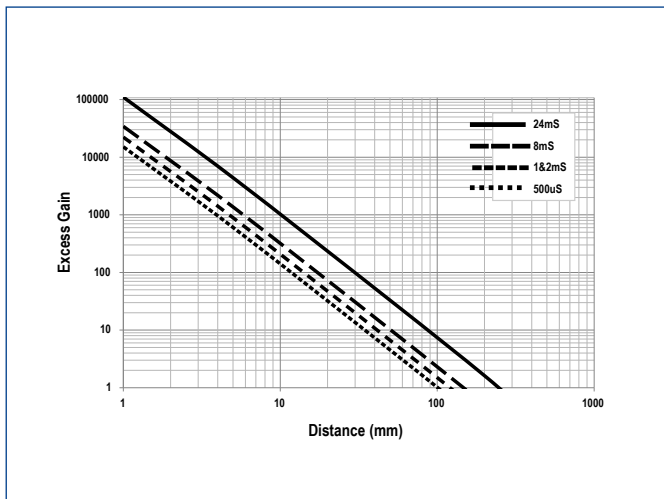

Through beam with 0.5 mm internal fiber optic diameter

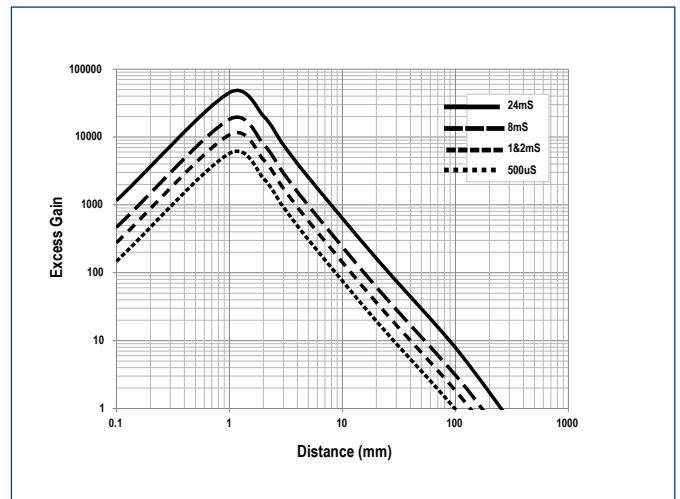

Diffuse proximity with 0.5 mm internal fiber optic diameter

S70-E3

	SUPER HIGH SPEED	HIGH SPEED	FAST	STANDARD	LONG RANGE	EXTRA LONG RANGE
Response Time	-	250 μ s	500 μ s	1 ms	4 ms	12 ms
Repeatability	-	100 μ s	150 μ s	180 μ s	180 μ s	180 μ s

EXCESS GAIN

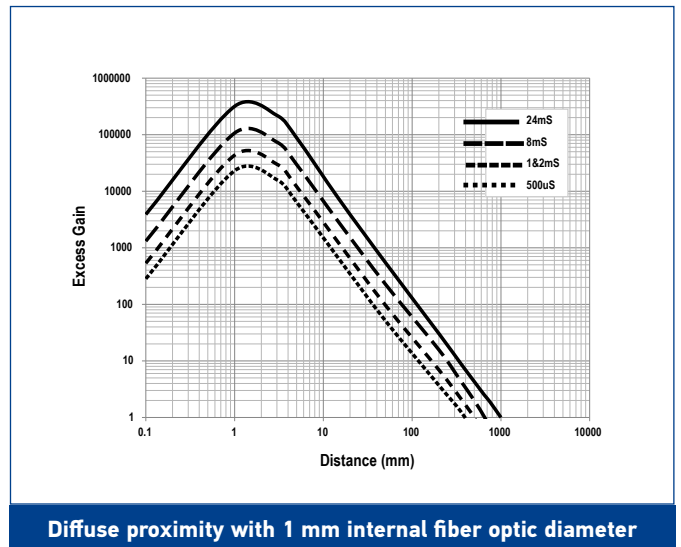
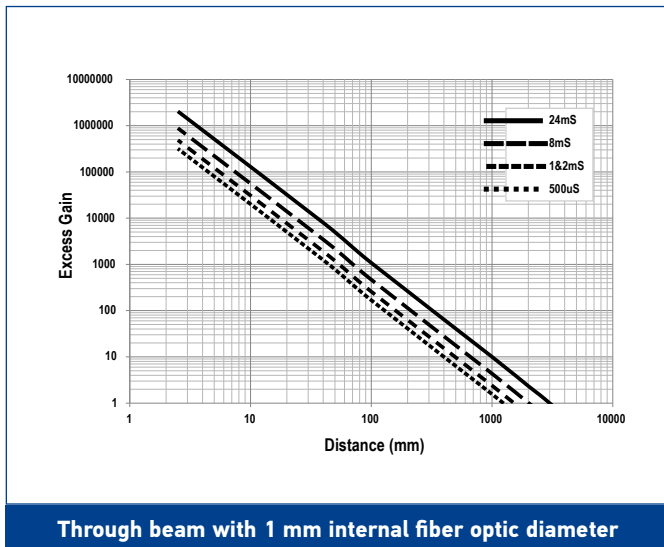

EXCESS GAIN

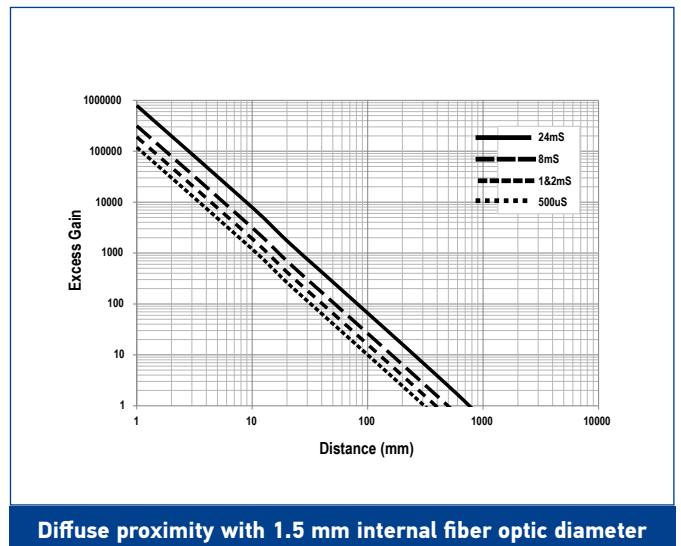
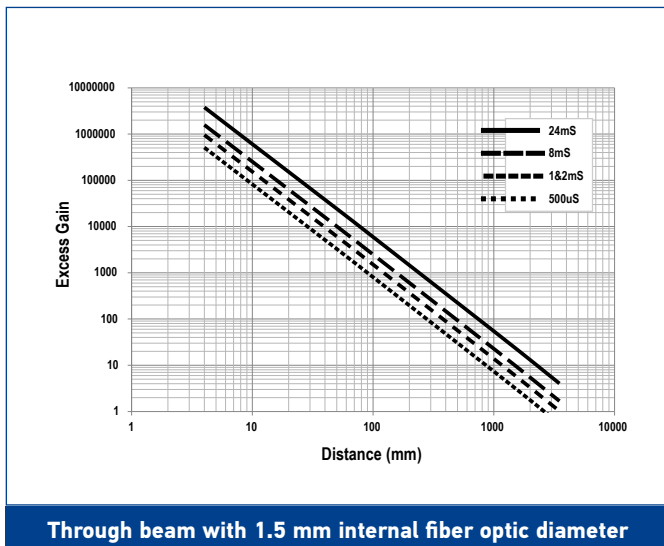

S70-E3

	SUPER HIGH SPEED	HIGH SPEED	FAST	STANDARD	LONG RANGE	EXTRA LONG RANGE
Response Time	-	250 μ s	500 μ s	1 ms	4 ms	12 ms
Repeatability	-	100 μ s	150 μ s	180 μ s	180 μ s	180 μ s

DETECTION AREA

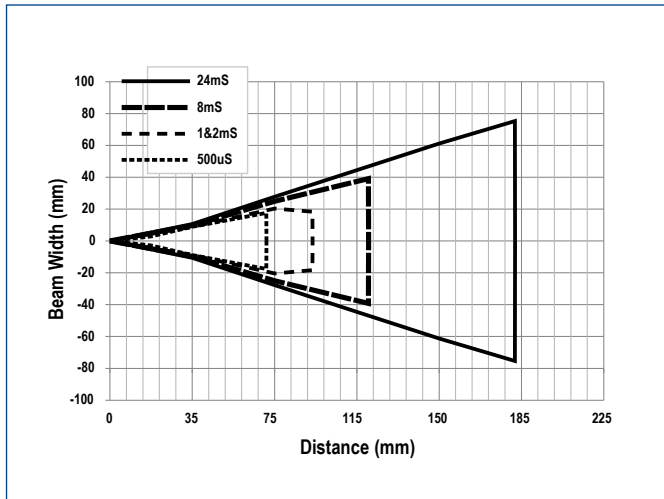

Through beam with 0.2 mm internal fiber optic diameter

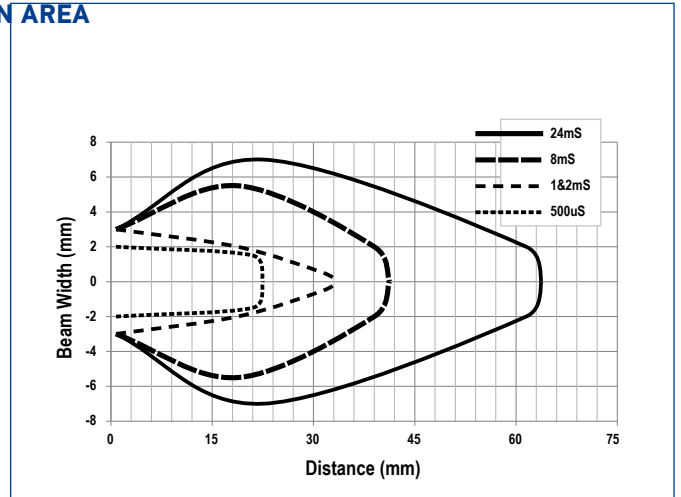

Diffuse proximity with 0.2 mm internal fiber optic diameter

DETECTION AREA

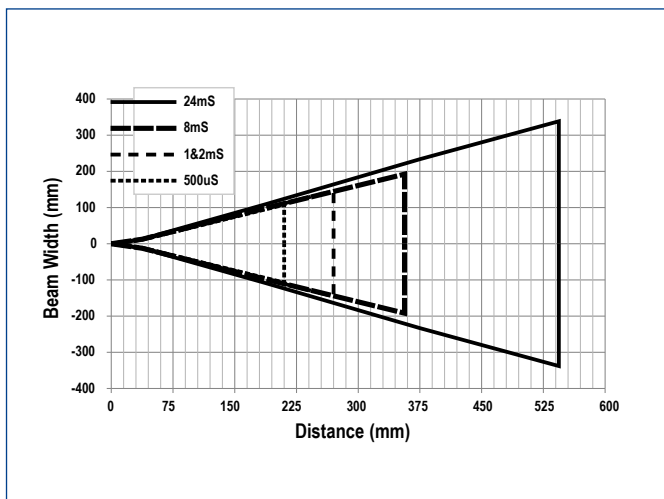

Through beam with 0.5 mm internal fiber optic diameter

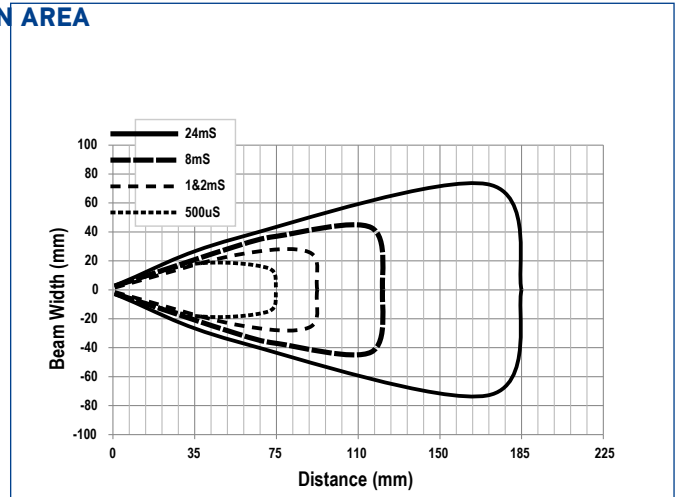

Diffuse proximity with 0.5 mm internal fiber optic diameter

S70-E3

	SUPER HIGH SPEED	HIGH SPEED	FAST	STANDARD	LONG RANGE	EXTRA LONG RANGE
Response Time	-	250 μ s	500 μ s	1 ms	4 ms	12 ms
Repeatability	-	100 μ s	150 μ s	180 μ s	180 μ s	180 μ s

DETECTION AREA

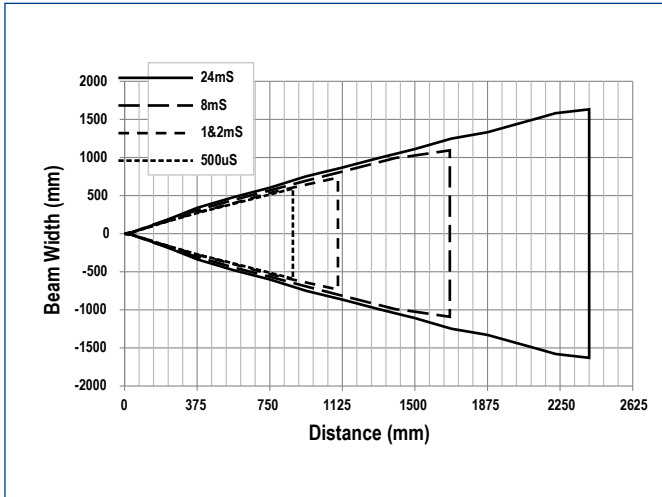

Through beam with 1 mm internal fiber optic diameter

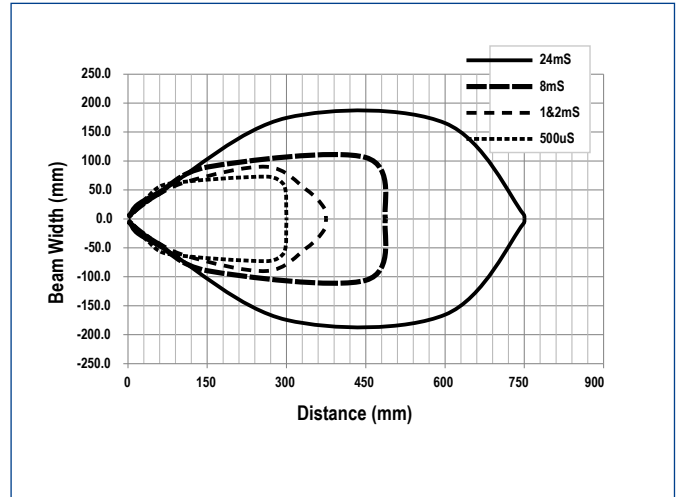

Diffuse proximity with 1 mm internal fiber optic diameter

DETECTION AREA

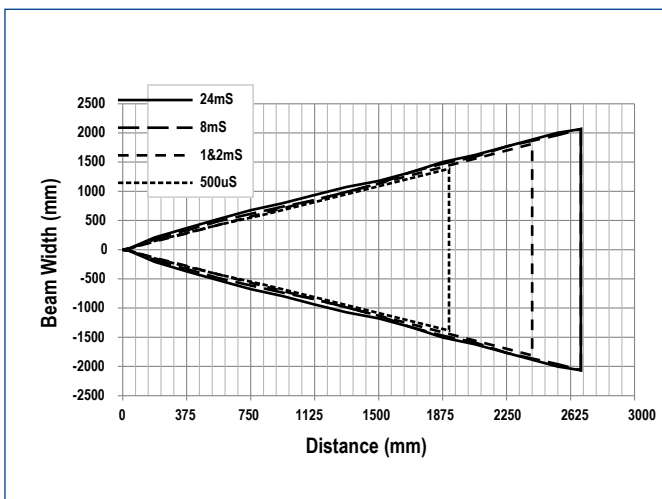

Through beam with 1.5 mm internal fiber optic diameter

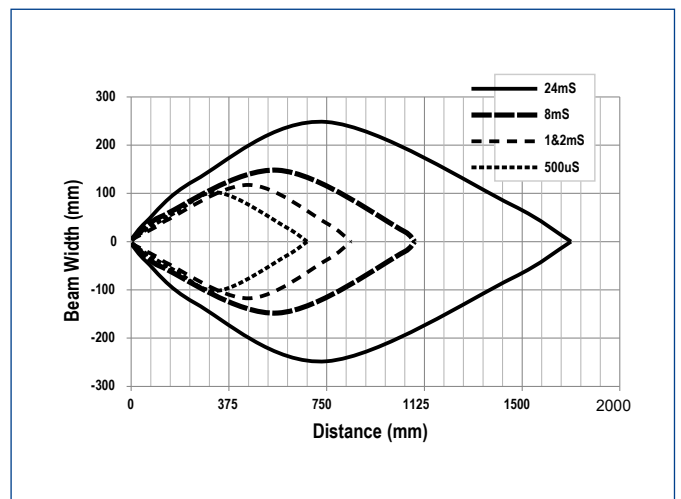

Diffuse proximity with 1.5 mm internal fiber optic diameter

MODEL SELECTION AND ORDER INFORMATION

OPTIC FUNCTION	RESPONSE TIME	CONNECTION	OUTPUT	MODEL	ORDER No.
Fiber Optic Amplifier	200 μ s ... 5 ms	2 m Cable	NPN	S70-2-E1-N	950561000
			PNP	S70-2-E1-P	950561010
		M8 Connector	NPN	S70-5-E1-N	950561060
			PNP	S70-5-E1-P	950561020
			PNP, push-pull IO-Link	S70-5-E1-PZ	950561030
			NPN	S70-5-E2-N	950561040
	10 μ s ... 1 ms	M8 Connector	PNP	S70-5-E2-P	950561050
			4...20mA, NPN	S70-5-E3-NI	950561100
		M8 Connector	0...10V, NPN	S70-5-E3-NV	950561080
			4...20mA, PNP	S70-5-E3-PI	950561090
			0...10V, PNP	S70-5-E3-PV	950561070
			250us...12ms		

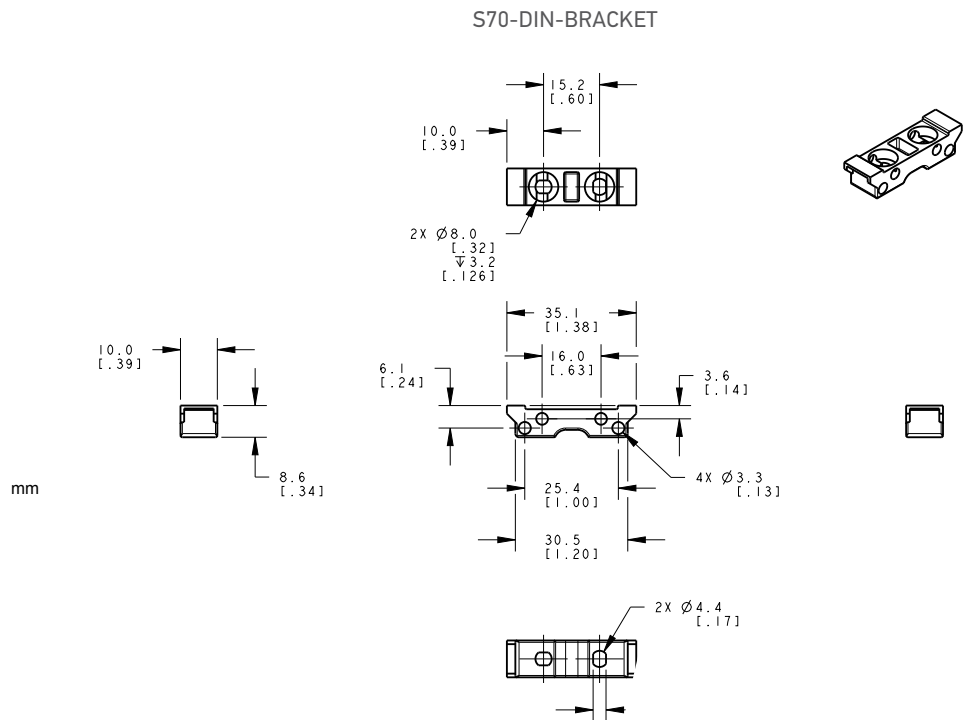
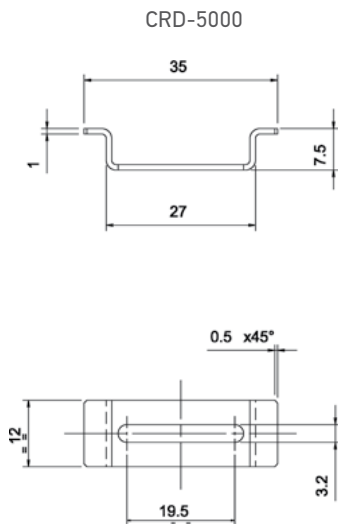

MODEL	DESCRIPTION	ORDER No.
CRD-5000	DIN rail mounting bracket	95ACC2790
S70-DIN-BRACKET	DIN rail mounting plastic bracket	95ACC8170

CABLES

TYPE	DESCRIPTION	LENGTH	MODEL	ORDER No.
Axial M8 Connector	4-pole, grey, P.V.C.	3 m	CS-B1-02-G-03	95A251420
		5 m	CS-B1-02-G-05	95A251430
		7 m	CS-B1-02-G-07	95A251440
		10 m	CS-B1-02-G-10	95A251480
Radial M8 Connector	4-pole, P.U.R.	2 m	CS-B1-02-R-02	95A251620
		5 m	CS-B1-02-R-05	95A251640
	4-pole, grey, P.V.C.	3 m	CS-B2-02-G-03	95A251450
		5 m	CS-B2-02-G-05	95A251460
		7 m	CS-B2-02-G-07	95A251470
		10 m	CS-B2-02-G-10	95A251530
	4-pole, P.U.R.	2 m	CS-B2-02-R-02	95A251630
		5 m	CS-B2-02-R-05	95A251650
Axial M12 Connector	5-pole, L coded power cable	3 m	CS-M1-02-B-03	95ACC0007
Axial M12 F/M8 M Connector	4-pole, double headed	3 m	CS-H1-02-B-03	95ACC0008
Axial M12 F/M12 M Connector	4-pole, double headed	3 m	CS-I1-02-B-03	95ACC0009

Rev. 03, 04/2019