

**BIZERBA**

... closer to your business

... Always in fashion ...

... Bizerba System class SC II scales



The new Bizerba System class stands for perfect weighing performance, encompassing a broad spectrum of weights. The scales are equipped with a high performance processor which utilises the latest communications technology and offers the highest level of flexibility in terms of individualising the settings – from the keypad layout to the software enhancements.

## ... Professional connections ...

### **Multi-functionality guaranteed**

SC II scales come in various different model variations, all optimally adapted to the relevant requirements – whether for serving customers, self-service, displaying the price or for use in the checkout area. The high quality weighing cells weigh small product quantities just as accurately as larger heavier loads. The various forms – platform scales, stand scales and scales with separate load receptor– combine weighing, labelling and cash till functions to form efficient work processes.

### **System integration guaranteed**

All of the SC II scales have one thing in common: the PC-based operating system Microsoft Windows® CE, the high performance 400 MHz processor and a 10/100 Mbit/s Ethernet network adaptor which enables up to 30 devices to communicate with the back office and between one another. The system can even be operated wirelessly, if required. The scales come with all the

relevant hardware interfaces as standard so that cash registers, scanners and e-cash terminals can be connected, hassle-free.

### **Efficiency guaranteed**

The SC II are already fitted with energy-saving components and now come with integrated lithium-ion battery technology as optional. This is an advantage with mobile trade or on market or special sales stalls as well as in the case of power cuts or fluctuations as the scales can function reliably for up to 10 hours without an external power supply. The scales can also be fitted with a 12 V adapter which enables them to be powered using a car battery.

### **Attractiveness guaranteed**

The Bizerba System Class fits in perfectly with any existing shop ambience thanks to its modern design and subtle case colour. Every last detail has been taken into consideration – including the ability to clean the scales in an instant. The suspended versions are particularly space-saving in design and can be positioned above any potentially unclean areas of the counter. The standing version impresses with its ergonomically designed operation, in direct eye contact with the customer. And the split version offers greater flexibility in the design of the operation area and the selection of the load receptor.





**Receipt printing**



**Label printing**



**Decorative labels**

**One printer, multiple applications**

The standard version of the SC II scales comes with a label printer which can produce receipts and adhesive price receipts in addition to labels (and decorative labels). This means that large amounts of text, as in the case of ingredients, recipes, recommended methods of preparation and advertising information can be printed out in a flexible manner using the best suited material. Label print-outs can also be reduced by printing 1 or 2 labels, depending on the length of text. And there are no more long queues caused by frequent paper changes and no more need to stockpile various pre-printed labels as individual layouts can be printed on blank paper. The use of Bizerba supplies however does increase the resilience and lifespan of the printhead as the labels and paper are optimally adapted to suit the Bizerba System class.

**What could be more cost-efficient? Do it yourself!**

As an alternative, a linerless printer can be used which operates using Bizerba linerless thermo-rolls without the need for carrier tape. An investment which brings plenty of advantages:

- **More labels**  
 due to longer run length  
 (Price saving approx. 40 %)
- **Less paper consumption**  
 due to the automatic adaptation of the paper length to the text length
- **Fewer roll changes**  
 even with increased customer numbers
- **Sticking not stapling**  
 Secure and hygienic adhesion to bags – none of the dangers presented by stapling
- **Less waste – No carrier tape**  
 Helps protect the environment and save on waste disposal costs
- **Only with Bizerba Linerless:**  
 Adhesive-free grip edge on receipt (European patent EP 1053289B2)

# SC II 100 / SC II 200 ...

## SC II 100

Platform scales for serving customers, self-service and price labelling. Checkout area solutions combined with a cash till drawer.



SC II 100 customer view

## SC II 200

Platform scales with customer display on stand for serving customers and price labelling.



SC II 100



SC II 200 customer view



SC II 100  
With Niro cash till drawer



SC II 200

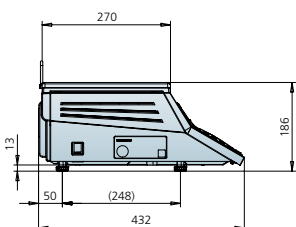

SC II 100

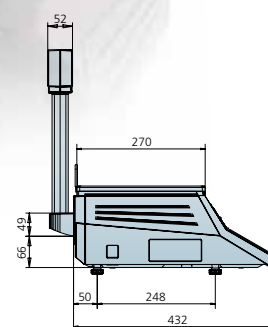
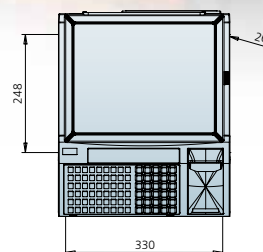
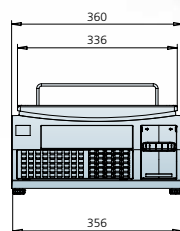

SC II 200

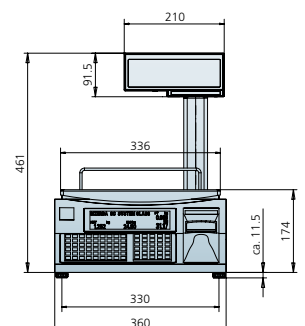



# SC II 100 G

## SC II 100 G

Platform scales with separate load receptor up to max. 150 kg for serving customers and displaying prices.

SC II 100 G customer view



SC II 100 G



SC II 100 G  
with load receptor type 18 A



SC II 100 G  
with load receptor type 150 (350)

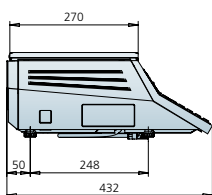

SC II 100 G

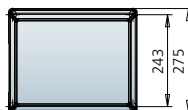
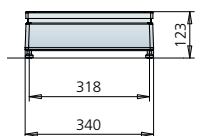
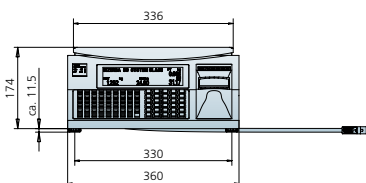

Load receptor type 18 A

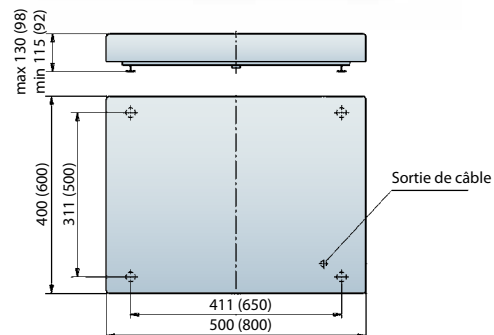

Load receptor type 150 (350)

### Informative display/display field

The LCD displays on the System class can be adapted to different lighting conditions via the dimmer function. Text and customer information of up to 35 characters can be displayed in a bright, clear and legible manner via the high resolution, back-lit graphics display. This enables the customer to follow all of the information, even if advertising text is also included. The six display lines guarantee optimal user operation and programming.



# SC II 400 ...

**BIZERBA**  
 ... closer to your business

## SC II 400

Suspended scales for serving customers or self-service, in particular in areas which require damp cleaning such as with fruit, vegetable and fish sales. Comes with 48 or 96 keys with a mix of components.



SC II 400 customer view



SC II 400

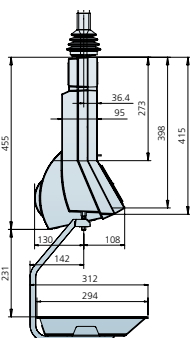
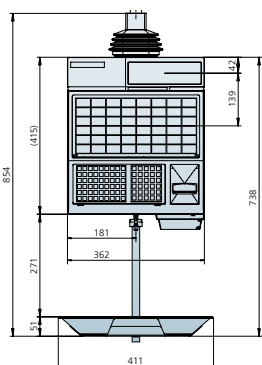

SC II 400







# SC II 500 ...

## SC II 500

Self-service or Quick-service scales with keypad and customer display on stand.  
Available with 48, 96 144 or 192 keys or with a mix of components.



SC II 500 Customer view



SC II 500

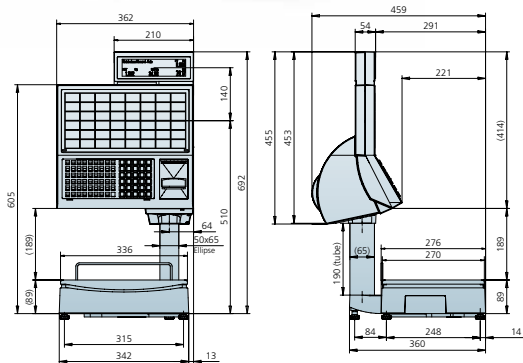

SC II 500 SB1 / QS1

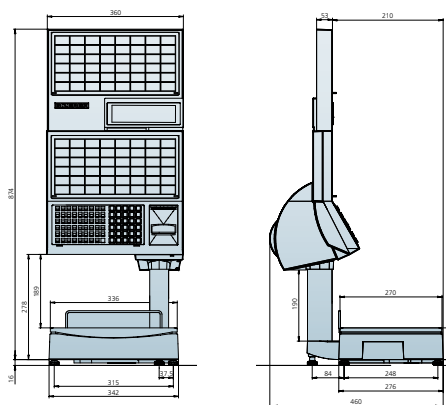

SC II 500 SB2 / QS2

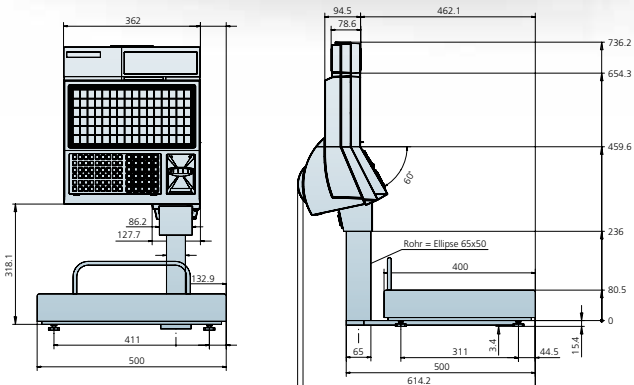

SC II 500 SB1 / QS1 with load receptor type 150

# SC II 800 ...

## SC II 800

Stand scales for serving customers or self-service. Checkout area solution combined with cash till drawer.



SC II 800 Customer view



SC II 800 with tactile keypad and Niro cash till drawer



SC II 800

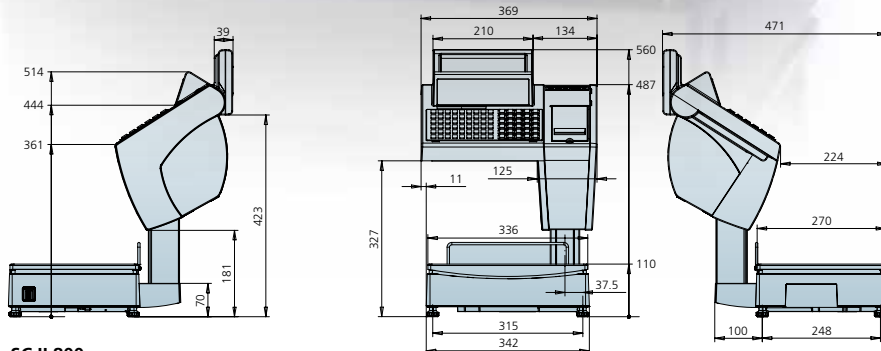

SC II 800

### Tailor-made right down to the reporting function

The Bizerba System class adapts to the user, and not the other way around. The flexible configuration of the tactile and membrane keypad enables the device to be individually adapted to your operational and/or service processes. The PLUs and functions are easy to modify. Even untrained staff members will quickly learn to use the scales. If required and as an additional help feature for temporary staff, coloured key pictograms can

also be added via a keypad frame. Just one press of the key is sufficient to initiate an entire functional process. This saves valuable minutes, avoids operational errors and enables time-controlled report issuing without the need for staff input: regular, daily, weekly or monthly reports can be automatically issued as required and on time.

**BIZERBA**

■ ... closer to your business



# BIZERBA

... Boost sales with  
Visual Merchandising ...



... natürlich  
**Frisch**  
Einfach lecker  
und voller Vitamine

Equipped with a customer supplied 7 inch screen (option), SC II scales display full-screen and long-term advertising. When the PLU is started, additional information, product images or additional purchasing information (cross-selling) can also be displayed on the customer screen. Contents can be loaded very easily, e.g. from a USB stick, over the Ethernet by manual distribution (FTP) or by using Bizerba *.RetailImpact* software.

# SC II 100 7" ...

## SC II 100 with 7" Display

Platform scale for serving customers.

7" customer screen for professional advertising and product information.



SC II 100 7" Customer view



Full-screen advertising



Long-term advertising

### Advertise your offers to specific target groups

The scale can store 12 advertising lists for 12 months with any number of images (1 to 99). In serving breaks, the full screen is free to display adverts (full-screen advertising). While serving, the advertising area is reduced automatically (long-term advertising).

Images in jpg and bmp file formats are suitable for full-screen and long-term advertising. The images are adapted automatically to the scale's screen resolution. This reliably avoids any impairment to scale functions (journal, data backup, updates, etc.), since the scale has enough memory capacity for advertising at all times.

# SC II 400 7" ...

## SC II 400 with 7" Display

Suspended scale for serving customers.  
in the fruit, vegetable or fish department.  
7" customer screen for professional  
advertising and product information.



SC II 400 7" Customer view



## Long-term advertising



# SC II 800 7" ...

**BIZERBA**  
... closer to your business

## SC II 800 with 7" Display

Stand scale for serving customers.

7" customer screen for professional advertising and product information.



SC II 800 7" Customer view

Full-screen advertising



The keys of the Bizerba System class can be individually adapted to your requirements as the keypad functions are flexible in terms of their configuration. The keypad layout can also be designed to suit your needs. Just one press of

the key is sufficient to initiate an entire functional process (macro). This prevents operational errors and enables, for example, time-controlled report issuing.

## ... Unique tailor-made keypads ...

### Operator keypads

When it comes to the operator keypad, you can choose from the standard membrane keypad or a tactile keypad.

### Membrane keypad



*Colourful keys make the device easy to use, even for temporary staff. Bizerba Screen Designer software is available, if required, to enable the individual design of the membrane keypad.*

### Tactile keypad



*The tactile keypad is tried and tested worldwide. It has a great feel and guarantees to offer secure, fast and comfortable operation. The silicon membrane also enables labelling of the keyboard.*



*Silicon membrane panel with 54 keys*



*Silicon membrane panel with 30 keys*



*Tactile keypad with optional 24 keys in keypad frame for use in self-service areas*



**Mixed components on self-service keypad  
 with large and small keys**

Text, PLU and graphics can all be displayed on the self-service keypad, depending on requirements: with 12, 24, 48, 72, 96, 120, 192, 216 tactile keys – or individual mixed component designs from 12 to 216 keys. The scope of the design is further enhanced by the addition of 4 different key sizes to make the operator

keypad layout even clearer. The result: greater clarity, user comfort and operational security. It is easy to find the right key even with large product ranges and the flexible programming of the keypad means that seasonal adaptations can be implemented quickly and effectively.



**Self-service keypad 48 keys**



**Self-service keypad 48 keys and 24 key frame added to operator keypad**



**Self-service keypad 96 keys and 24 key frame added to operator keypad**



**Self-service keypad 48 keys and operator keypad (shown with optional tactile keypad)**



**Self-service keypad 96 keys and operator keypad (shown with optional tactile keypad)**



**Self-service keypad – mixed components**



**Self-service keypad for entering item number via the numbers**

Even the basic version of the Bizerba System class comes with a data exchange interface. Personnel planning can be optimised using a host connection and based on customer frequency analyses. The control and planning of the product assortment is also possible based on the item, product group, analyses of whether products are selling well or not and user information.

## ... Tomorrow's technology, today ...

### Remote data management and updates

The remote service supports and accelerates communication between the headquarters and scales. All adjustments can be made and checked from a remote location. Data on all of the scales can also be updated and software functions activated or de-activated. The scales can also be adjusted in real time to take account of price offers (e.g. happy hour) or customer loyalty programmes (e.g. linking loyalty rewards with products).

Applying new weighing programme standards to the entire scales system is also hassle-free. All data is saved automatically via the remote update function and then fed back to the scales database. An e-mail will then be sent, reporting whether the programme update for the relevant scales has been successfully completed. This saves both valuable time and costs for the service employees on-site. It is also a reliable means of ensuring that all of the devices are operating using the same data, without any time-consuming labour-intensive checks. The high

performance and fast-operating hardware of the Bizerba System class guarantees fast operation and forms the basis for future updates and expansions. This means that users can implement new standards and ideas in a fast and flexible manner.

### Added value you can count on

The integrated 32 MB database means that there is no need to add additional memory cards and enables the entire product range to be stored by each set of scales. As a result, all of the scales can easily be used in another department in the event of a malfunction or shortage, thereby increasing security and availability. Large quantities of item data (such as basic price and unit price), product descriptions, product groups and shelf lives can be downloaded as standard. And here is plenty of storage capacity left over for a comprehensive reporting system – to present the turnover for the various product groups, optimise storage or for periodic comparisons of various turnover levels. And last but not least, sales can be increased and managed economically using the Bizerba System class through targeted price reductions on perishable goods, supported by customer loyalty card systems and a turnover-based staff reward system.



***Bizerba System Class scales fit in perfectly with the available IT infrastructure (optional wireless). The addition of an inventory control system means that price modifications, new items, special deals and turnover analyses can be carried out in a matter of seconds. This enables the full range of SC II services to be used.***

The next generation of retail concepts – all from one place and with specialist expertise from the fresh foods industry.

#### Ideal form and function

The daily cleaning of the scales is made much easier thanks to the smooth case surface and protected wear-free keys. The print heads simply fold away to enable the thorough cleaning of the printer. And if something isn't working properly, the Bizerba Service can offer fast and competent support.

The protection of your investment through the preventative care and maintenance of the devices is easily and effectively enhanced through the modular offers included in the Bizerba service contracts. The wide range of services available is further extended by the comprehensive range of original Bizerba accessories and various financing and leasing options offered by BLG Bizerba Leasing.

Whatever form you choose, it's always fun to work with the Bizerba System class devices as they are so easy to operate and run smoothly. This is all thanks to the high quality design and material used.



**SC II**

<b>Weighing range</b>	3/6 kg	6/15 kg	15/30 kg <sup>1)</sup>	30 kg <sup>1)</sup>
<b>Scale interval</b>	1/2 g	2/5 g	5/10 g	5 g
<b>Minimum load</b>	20 g	40 g	100 g	100 g
<b>Max load</b>	-6 kg	-15 kg	-30 kg	-30 kg
Automatic zeroing function, programmable zeroing key				<sup>1)</sup> Option

**SC II 100 G with load receptor type 150/350 in (kg)**

<b>Weighing range</b>	6/15	15/30	30	30/60	60	120	60/150
<b>Scale interval</b>	2/5 g	5/10 g	5 g	10/20 g	10 g	20 g	20/50 g
<b>Minimum load</b>	40 g	100 g	100 g	200 g	200 g	400 g	400 g

**Load receptor type 150/350**

- Bell-shaped weighing platform is made of stainless steel
- The main and platform frame are made of milde steel (galvanized) or in stainless steel

**Display**

- LCD dot matrix display 64 x 240 dot with LED back lighting, colour: orange
- Adjustable contrast and brightness
- Character count for text: approx. 35
- Number of lines for programming: 6
- Weight display: 4 or 5-digit
- Basic price display: 6-digit, Sale price display: 7-digit
- Tare weight display: 4 or 5-digit

**Customer screen (option) for SC II 100, 400 and 800**

- 7" TFT LCD colour screen with LED backlighting, WVGA resolution (800 x 480 dots)
- Product images
- Cross-selling images
- Full-screen advertising
- Long-term advertising

**Keypad**

- Membrane or tactile keypad (option), 84 keys incl. 30 function and 54 direct keys for PLU and/or other functions
- Flexible programming
- Integrated programming keypad
- Membrane keypad can be labelled via insert and tactile keypad via frame (option)
- Frame attached to tactile keypad with 24 self-service keys

**Self-service keypad (SC II 400 and SC II 500)**

- Short-stroke, tactile with membrane
- Number of self-service keys: 48 standard and a further 48 via additional panel with model SC II 500 (option)
- Frame attachable to operator keypad with 24 self-service keys (option)
- Number of self-service keys: max. 72 or 120
- Extra large self-service keys: max. 12 or 24
- Mixed components with different key sizes possible

**Fast operator keypad (SC II 400 und SC II 500)**

- Short-stroke, tactile with membrane
- Number of QS keys: 96 standard and a further 96 via additional panel with model 500 (option)
- Extra large QS keys: max. 12 or 24
- Mixed components with different key sizes possible

**Label printer**

- 432 dots
- Resolution: 8 dots/mm
- Print speed: 102 mm/s
- Graphics, logo printing, large/small lettering, various font types and sizes, EAN/UPC barcodes
- Label length max. 300 mm, label width max. 58 mm, print width 52 mm
- Flexible configuration of label size and layout, various pre-defined label sizes and layouts
- Transposable onto adhesive or receipt paper
- Label layout on receipt paper
- Selectable counterfoil

**Linerless printer**

- Like the label printer
- Receipt and label layout without carrier tape
- Variable label length depending on data quantity

**Operating system**

- Microsoft Windows® CE

**Data storage**

- 32 MB on SD card

**Programmable data per PLU**

- Basic/ unit price, product description max. 500 characters, additional text max. 6000 characters, product images, product group, shelf life, barcode, price override, tare weight, VAT, offer price, offer text, by count (= number of items), fixed weight, price basis kg, 100 g, 500 g, lb, 1/4 lb, graduated price, timed campaigns, 3 price categories

**Operating modes**

- Operator, self-service and quick service- Cash till functions with pay-in/out function
- Manual or automatic price labelling, with or without addition
- Weight and fixed price labelling
- Pre-selected number for automatic printing

**Reports/ evaluations**

- Comprehensive flexible configuration of reporting for PLU, product groups, main product groups, VAT, sales staff, department, main department, training
- Frequency of sales for department, product groups and sales staff
- Various assortment criteria
- Price modification journal, electronic log of receipts
- In combination with licensed software: cashier, inventory, wastage weighing, returns, operator time recording

**Other service features**

- Function menus, weighing programmes loadable via interface, various tare weight options, operational help on display, password protected menu, remote programme update, remote service, language switching of menu

**Other service features with use as operator scales**

- Receipt cancellation, scrolling function with cancellation, paying in/out, foreign currency conversions, seller log on/off, bonus points, customer card

**Licences for software module**

- Proof of origin, till function, scanning, electronic cash, operator time recording, inventory, weighing, branch returns

**Interfaces**

- 1 x Ethernet interface (10/100 Mbit/s) for the scales system with up to 32 devices or to connect to computer, for automatic configuration of the network parameters DHCP and DNS. Data protocol. TCP/IP and UDP, data transfer by XML file
- 2 x serial interfaces RS 232 for connecting a scanner or electronic cash terminal (interface protocol subject to licence)
- 1 x USB port for version with 7" TFT colour screen
- 1 x interface (RJ 12) for controlling cash till drawer
- Wireless LAN (option) IEEE 802.11 b/g/a for floating vendor operating with up to 16 devices or for connecting to a computer
- Various forms of encryption and authentication

**Battery operation (option)**

- Internal lithium-ion battery pack (not for the SC II 400 model and not in combination with wireless LAN), can be charged via the scales power supply within 3.5 hours
- Operating time approx. 10 hours with LCD dot matrix display
- Operating time approx. 2 hours (UPS) with 7" TFT colour screen (Operating time dependent on ageing and charge state of rechargeable battery)

**External battery operation (option)**

- 12 V, via a special battery connection cable (not for the SC II 400 model and not in combination with wireless LAN)

**Temperature range**

- -10 °C to + 40 °C

**Operating voltage**

- (- 15 + 10 %) 230 V or (- 15 + 10 %) 120 V

**Power consumption**

- at 230 V min. 60 mA / max. 250 mA, at 120 V min. 75 mA / max. 350 mA

**Network frequency**

- 50 / 60 Hz

**Members of the Bizerba Group**

Bizerba GmbH & Co. KG  
 Wilhelm-Kraut-Straße 65  
 72336 Balingen  
 Germany  
 Tel. +49 7433 12-0  
 Fax +49 7433 12-2696  
 marketing@bizerba.com  
 www.bizerba.com

Bizerba UK Limited  
 2-4 Erica Road  
 Stacey Bushes  
 Milton Keynes  
 Buckinghamshire  
 MK12 6HS  
 U.K.  
 Tel. +44 1908 682740  
 Fax +44 1908 682777  
 sales@bizerba.co.uk

Bizerba USA Inc.  
 1804 Fashion Court  
 Joppa, MD 21085  
 USA  
 Tel. Office +1 732 565-6000  
 Tel. Service +1 732 565-6001  
 Fax +1 732 819-0429  
 us.info@bizerba.com  
 www.bizerbausa.com

Bizerba Canada Inc.  
 2810 Argentinia Road #9  
 Mississauga,  
 Ontario L5N 8L2  
 Canada  
 Tel. +1 905 816-0498  
 Fax +1 905 816-0497  
 ca.info@bizerba.com  
 www.bizerba.ca

Bizerba (Shanghai) Weigh Tech & Systems Co.Ltd.  
 D-3, Qianpu Road, Shuhui Real Est.Park  
 East New Area of Songjiang, Ind.Zone  
 201611 Shanghai  
 China  
 Tel. +86 (21) 67 60 09 99  
 Fax +86 (21) 67 60 09 98  
 marketing.china@bizerba.cn  
 www.bizerba.cn