



# SM-5000BS

PC Based Self Service System Scale

## Simple, Fast & Intuitive Operation

Visual & audio operation guidance makes operation a breeze

Email alert when label ends reduces down time

High speed printing reduces waiting time



SM-5000BS

*Searching for  
a New Balance*

## Self Service Scale with Intuitive User Interface

- Smooth, fast and simple operation
- Visual and audio prompts to guide operation
- Email alert for label change
- Fast printing speed of 150mm/sec\*
- Innovative full colour screen to enhance store image
- Hot keys can be set to display most popular choices simplifying the key selection process

## Attractive & High Contrast Electronic Signage

### InfoCard

Database updates at the server are wirelessly transmitted over to the InfoCard, ensuring price and product information are in sync with the checkouts at all times.



### e.LABEL with Integrated Hi-Touch

e.LABEL with integrated Hi-Touch function acts as a remote PLU preset key to ensure fast and easy PLU retrieval. When tapped, the PLU is automatically sent to the DIGI PC based self service scale.



## Multi - Media Possibilities

Up sell or cross sell with the multi-media functionality by simply interfacing with a remote display.



Remote Display

## Built - In Barcode Scanner

Workspace is reduced as the SM-5000BS comes with an optional barcode scanner that is ergonomically built into the scale.



Built - In Barcode Scanner

### Specifications

Capacity	Max 6kg	Max 15kg / 30lb	Max 30kg
Single Interval	e = 2g	e = 5g / 0.01lb	e = 10g
	e = 1g	e = 2g	e = 5g
Capacity	Max 3 / 6kg	Max 6 / 15kg	Max 15 / 30kg
Multi Interval	e = 1 / 2g	e = 2 / 5g	e = 5 / 10g

Model	SM-5000BS	SM-5500B (12.1)
Dimension (mm)	385.0(W) x 436.0(D) x 578.6(H)	385.0(W) x 507.0 Max(D) x 148.1(H)
Customer Display	12.1 Inch Colour LCD with Touch Screen	
CPU	iMX31	
Memory	512MB DDRAM (Factory Default)	
Label Size (mm)	80(W) x 240(H) (Max)	
Label / Receipt Roll Diameter	125mm (Max)	
Paper Width	80mm (Max)	
Printing Speed	Up to 150mm/second*	
Power Source	AC 100 / 110 or 220 / 230 / 240 Volts (50/60 Hz) Factory Default	
Operating Temperature	- 10°C to +40°C	
Humidity	15% to 85% RH	
Standard Interface	RS232C, Ethernet 10/100 Base T, USB 2.0 Host	
Net Weight	18.9kg	13.2kg
Options Available	Wireless LAN (IEEE 802.11b/g), Scanner (In Built), Card Reader, Remote Display, Linerless Receipt Printer	
Others / Variant	SM-5000 series, SM-5000H, SM-5500 Console	

\*To achieve maximum printing speed, high sensitivity thermal paper is necessary. Contact DIGI for details.

### Dimension (mm)

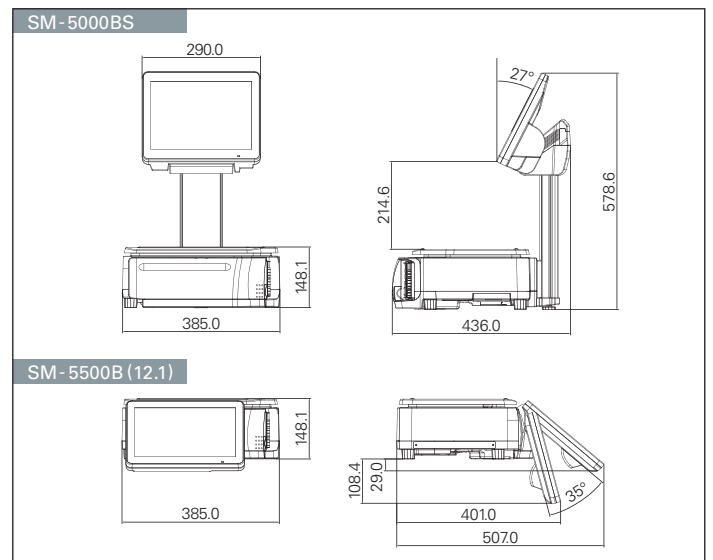

• Specifications are subject to change without prior notice.  
• Meet or exceed OIML Class III requirements.

## TERAOKA WEIGH-SYSTEM PTE LTD.

4 Leng Kee Road #05-02/03/04/05/11  
SIS Building SINGAPORE 159088  
TEL : +65 6472 2996  
SALES: +65 6378 5387  
FAX : +65 6863 4614  
URL : www.teraoka.com.sg  
E-MAIL : bdd@teraoka.com.sg

## TERAOKA SEIKO CO., LTD.

13-12 Kugahara 5-chome, Ohta-ku,  
Tokyo 146-8580, JAPAN  
TEL : +81-3-3752-2131  
FAX : +81-3-3752-2801  
URL : www.digisystem.com  
E-MAIL : info@hq.digi.co.jp