

# EC II 100 E / C / CD

## Retail scale

### Operating instructions

as from program version 2.10

61079852148 en-US

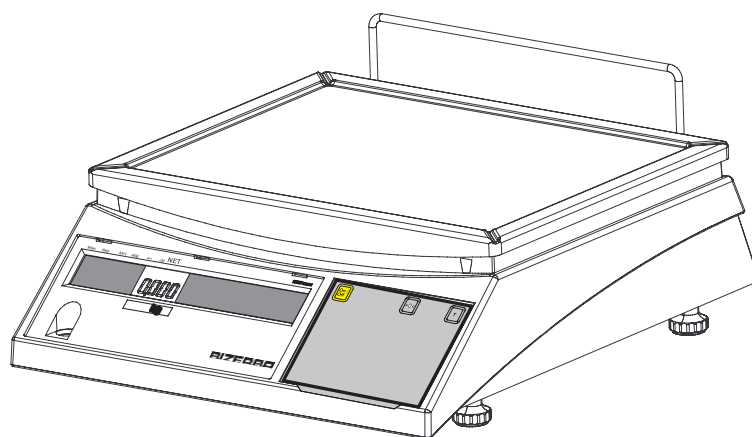
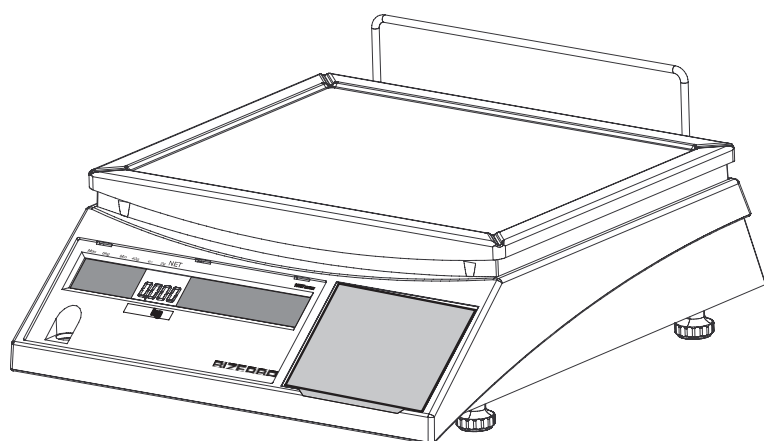

**Bizerba Service**  
**www.bizerba.com**

© 04 / 2016

Alle Rechte vorbehalten  
All rights reserved  
Tous droits réservés  
Reservados todos los derechos  
Tutti i diritti riservati

Bizerba GmbH & Co. KG,  
72336 Balingen

Postfach 10 01 64  
72301 Balingen, Germany  
Telephone (+49 7433) 12-0, Fax (+49 7433) 12-2696  
E-mail: [marketing@bizerba.com](mailto:marketing@bizerba.com)  
Internet: [www.bizerba.com](http://www.bizerba.com)

# Contents

<b>1</b>	<b>About these instructions .....</b>	<b>5</b>
1.1	Safe-keeping .....	5
1.2	Target group .....	5
1.3	Symbols used .....	5
1.4	Warnings .....	6
<b>2</b>	<b>About the device.....</b>	<b>7</b>
2.1	Device types .....	7
2.2	Optional batter pack module .....	7
2.3	Intended use .....	7
2.4	Identification plate .....	7
2.5	Verification information .....	9
2.6	Standards and directives .....	9
2.6.1	Measuring technology .....	9
2.6.2	Electromagnetic compatibility .....	10
2.6.3	Electrical safety .....	10
2.7	Operating conditions .....	10
2.7.1	Start-up and operation .....	10
2.7.2	Modifications and spare parts .....	11
2.7.3	Repair or service .....	11
2.8	Warranty .....	11
2.9	Disposal of devices/environmental protection .....	11
<b>3</b>	<b>Safety instructions .....</b>	<b>13</b>
3.1	Requirements for operating personnel.....	13
3.2	Operational safety .....	13
3.2.1	Electricity.....	13
3.2.2	Cleaning.....	13
3.3	System-related sources of hazards .....	14
<b>4</b>	<b>Installation.....</b>	<b>15</b>
4.1	Transport and storage.....	15
4.2	Installation and assembly.....	15
4.2.1	Requirements to the place of installation .....	15
4.2.2	Unpacking .....	15
4.2.3	Leveling of scale .....	16
4.3	Power supply .....	16
4.3.1	Mains connection .....	16
4.3.2	Battery pack/battery .....	18
4.3.3	External 12V battery operation (optional) .....	22
4.4	Decommissioning.....	23
<b>5</b>	<b>Device and operating controls .....</b>	<b>24</b>
5.1	Display .....	24

5.2	Keyboard.....	24
5.2.1	Membrane keyboard.....	24
5.2.2	Key functions .....	25
5.2.3	Scale without keys (control scale).....	25
<b>6</b>	<b>Operation.....</b>	<b>26</b>
6.1	Switching scale on, off and zero setting.....	26
6.1.1	Switch-on .....	26
6.1.2	Switch off .....	26
6.1.3	Zero setting .....	27
6.2	Tare functions .....	27
6.2.1	Tare balancing for unknown tare values .....	27
6.3	Programming .....	29
6.3.1	Activate menu input .....	29
6.3.2	Menu call-up, menu selection and escape menu .....	30
6.3.3	General programming sequence .....	30
6.3.4	Programming overview .....	31
6.3.5	Configuration menu Pr5 - - .....	31
6.3.6	Service menu Pr 7- - .....	33
<b>7</b>	<b>Troubleshooting .....</b>	<b>37</b>
7.1	Interference suppression .....	37
7.2	Error descriptions .....	37
7.3	Error messages.....	37
<b>8</b>	<b>Maintenance.....</b>	<b>39</b>
8.1	Cleaning.....	39
8.2	Maintenance .....	39
<b>9</b>	<b>Technical data.....</b>	<b>40</b>
9.1	Dimensions .....	40
9.2	Power supply .....	40
9.3	Special ambient conditions .....	40
	<b>Subject index .....</b>	<b>41</b>
<b>10</b>	<b>Annexe.....</b>	<b>43</b>
	Declaration of conformity EC II .....	44
	EU declaration of conformity EC II.....	45

# 1 About these instructions

Read the operating instructions carefully before connecting and switching on the device so that you can make most of the device's quality and possible applications.

These operating instructions explain how to operate and set the device.

It also includes functions that are only required by Bizerba Service. Contact your Bizerba specialist if necessary.

Bizerba products undergo continuous further development and are subject to different country-specific regulations. Examples of pictures and graphics included in these instructions may vary from the version you have received.

## 1.1 Safe-keeping

These operating instructions are an integral part of the device and must be kept next to it, easily accessible for all personnel.

When selling this device, these operating instructions have to be attached in their entirety.



## 1.2 Target group

The device must be operated by trained personnel only. This means that the operator has to be familiar with the contents of these operating instructions.

Installation, maintenance and repairs must be performed by Bizerba authorized specialists only.

## 1.3 Symbols used

Various symbols are used in these instructions.

Symbol	Description
	Text with arrow prompts you to carry out an action.
	A key symbol prompts you to press this key.
<Key>	Text within < > refers to a key.
<Key> + <key>	Key combination. Press and hold first key, press second key.
"Display"	Text within " " shows the display text.
	Item number in figure.

### Information



Additional information for better understanding.



### Instructions



These instructions must be strictly observed.

## 1.4 Warnings

Warnings are divided into danger levels by the signal word above the warning symbol. Structure of warnings and meaning of signal words are described in these instructions as follows.

	<p><b>⚠ DANGER</b></p> <p><b>Source of danger with high risk of imminent danger to persons!</b>  <b>The consequences are:</b>  <b>life threatening injuries,</b>  <b>serious health damage</b></p> <ul style="list-style-type: none"> <li>– Measurements for prevention of danger are specified.</li> </ul>
	<p><b>⚠ WARNING</b></p> <p><b>Source of danger with medium risk of possible danger to persons!</b>  <b>The consequences can be:</b>  <b>serious injuries,</b>  <b>damage to health,</b>  <b>serious damage to property</b></p> <ul style="list-style-type: none"> <li>– Measurements for prevention of danger are specified.</li> </ul>
	<p><b>⚠ CAUTION</b></p> <p><b>Source of danger with low risk of possible danger to persons!</b>  <b>The consequences can be:</b>  <b>injuries,</b>  <b>damage to property.</b></p> <ul style="list-style-type: none"> <li>– Measurements for prevention of danger are specified.</li> </ul>
	<p><b>NOTICE</b></p> <p><b>Source of danger, improper use!</b>  <b>Damage to property can result.</b></p> <ul style="list-style-type: none"> <li>– Measurements for prevention of danger are specified.</li> </ul>

## 2 About the device

### 2.1 Device types

EC II 100 E

With tare, ON/OFF and set zero key

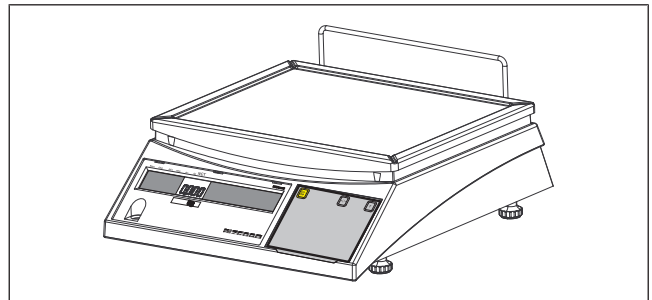

Illustration 1: EC II 100 E

EC II 100 C control scale

The control scale does not have any keys.

Versions:

- Verified control scale
- Non-verified control scale with the following text on the glass pane:
  - ① "Non-verified control scale. Price will be calculated at verified checkout scale"

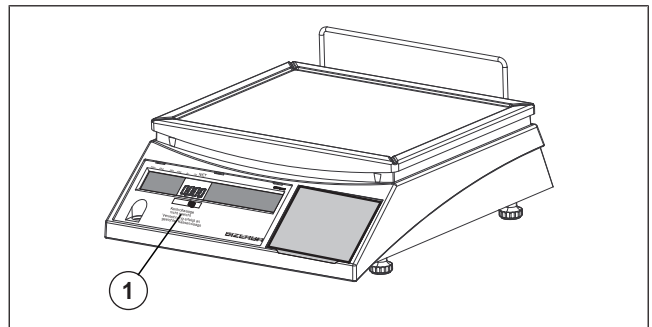
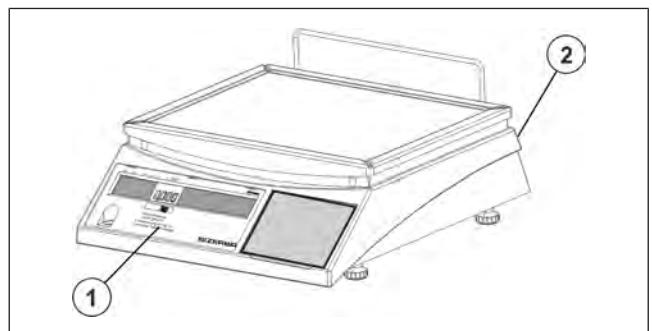

Illustration 2: EC II 100 C

EC II 100 CD control scale with customer display

- ① Operator display
- ② Customer display



### 2.2 Optional batter pack module

The rechargeable battery module is used to connect the battery/rechargeable battery block and also contains the battery charging circuit. It allows the scale to be battery-operated.

### 2.3 Intended use

The EC II 100 E and C scale is designed as a control scale to be used by customers, for mobile vending and goods receiving inspection.

Only use the device in accordance with intended use.

### 2.4 Identification plate

Identification plate of verified scale with EC type-approval.

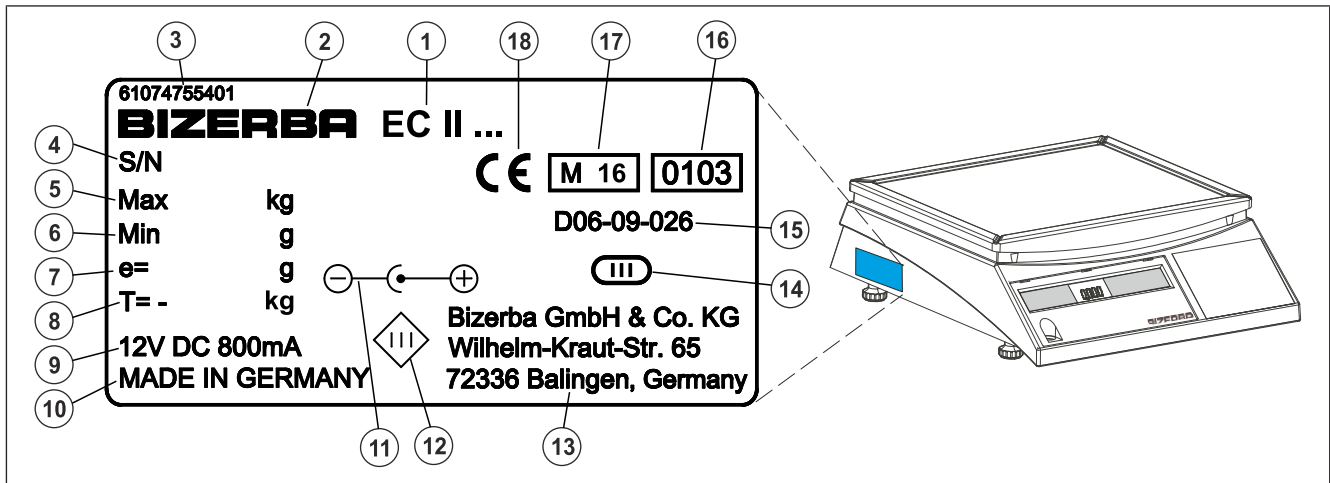

Explanations of the individual labels:

①	EC II ...	Type designation
②	Bizerba	Manufacturer
③	61074755401	Identification plate no.
④	S/N	Device No.
⑤	Max 6 kg	Maximum load
⑥	Min 40 g	Minimum load 40 g
⑦	e = 2 g	Verification scale interval 2 g
⑧	T= - 6 kg	Subtractive maximum tare load
⑨	12V DC 800 mA 9V DC 200 mA	Electrical data
⑩	MADE IN GERMANY	Country of manufacture
⑪	⊖ — ⊕	Connector for plug-in power supply unit and external battery operation
⑫	⚡	Symbol for protective low voltage, protection class 3
⑬	Bizerba GmbH & Co. KG	Manufacturer's address
⑭	III	Scale accuracy class III
⑮	D06-09-026	No. of EC type approval
⑯	0103	Identification number of notified body "Weights and Measures authorities - Stuttgart"
⑰	M 16	Metrology mark with the last two digits of the year when the marking was attached.



18	CE	CE marking
----	----	------------

## 2.5 Verification information

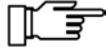

### Note related to scales being used in Germany.

If new or refurbished devices [...] are used, they need to be registered at the notified authority according to state law, at latest six weeks after setting into operation.

### Metrological notes for EU countries

The identification plate of the scale has a CE mark followed by the metrology mark (M + year two-digital; framed) and the number of the notified body. Until 04/19/2016 the green **M** was used as part of the metrology marking. Such a scale can be started up and operated on-site provided that it is not connected to an auxiliary device which is subject to metrological approval.

Scales which are connected on site to an auxiliary device which is subject to metrological approval must undergo a conformity assessment or metrological approval. Only then, legal for trade use is permissible.

Scales without metrology mark or control marks may not be used in legal for trade applications.

Scales calibrated for a certain gravity zone (specified on the scale) must not be used in other zones.

As per legal requirements, the scale user must ensure that the scale is used for its intended purpose. This includes the observance of legal requirements, especially in case of changes, amendments and extensions.

### Information on verification (early re-verification)

The verification of a scale is executed according to the respective statutory country regulations. The verification validity period for non-automatic scales (up to 3 tons), for example, is generally 2 years in Germany. The verification validity starts as soon as the device is put on the market.

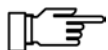

When conformity assessment is carried out by Bizerba the scale is sealed by means of control marks with marking "Gesichert BIZERBA" on the control marking locations. Verifications must be carried out by the operator of the scale according to the legal requirements.

### Verification information for non-EU countries

The statutory regulations of the specific countries must be observed.

## 2.6 Standards and directives

### 2.6.1 Measuring technology

2014/31/EC

Non-Automatic Weighing Instruments Directive (NAWI)

OIML R76-1                      Organisation internationale de métrologie légale  
Nonautomatic weighing instruments

DIN EN 45501                    Metrological aspects of non-automatic scales

## 2.6.2 Electromagnetic compatibility

2014/30/EC                      EMC Directive

DIN EN 61000-6-1              Interference immunity  
Living, business and industrial areas as well as small busi-  
nesses

DIN EN 55022                    Interference emission for information technology equipment

DIN EN 61000-3-2              Harmonic currents

DIN EN 61000-3-3              Voltage fluctuations and flickers

GB 9254-1998                  Information Technology Equipment - Radio Disturbance Charac-  
teristics - Limits and Methods of Measurement

## 2.6.3 Electrical safety

2014/35/EC                      Low voltage directive

DIN EN 60950-1,  
VDE 0805                        Information technology equipment - Safety

DIN EN 60529                  Protection types through housing (IP code)

## 2.7 Operating conditions

- ⇒ Please follow the operating conditions prior to start-up and during operation.
- ⇒ If you are in doubt concerning the practical application of these conditions, please contact Bizerba or the responsible customer service.



- For safety reasons, the machine should be turned off immediately if it displays faults repeatedly, or damage is incurred of any type or if there is a possible risk of injury.
- Please inform the next customer service agent.

For other manufacturers' equipment included in our scope of supply, the respective manufacturer's regulations take preference if they deviate from our conditions.

### 2.7.1 Start-up and operation

- ⇒ Only put device into operation after the supervision and operating staff has carefully read the operating and programming instructions.
- ⇒ Only carry out programming as per our operating and programming instructions.
- ⇒ Please pay special attention to and memorize all safety and hazard information!
- ⇒ Only let trained personnel operate the device.
- ⇒ Carry out regular training!

⇒ Only use equipment for its intended purpose.

### 2.7.2 Modifications and spare parts

- ⇒ Please, use only Bizerba original wear and tear parts, spare parts and replacements parts.
- ⇒ Modifications to the devices require our prior written consent.

### 2.7.3 Repair or service

- ⇒ Repair or service of the scale may only be carried out by trained and qualified Bizerba personnel.
- ⇒ Send device to nearest service center for repair.
- ⇒ Always return device in the original box (keep box for future use).

## 2.8 Warranty

Installation, start-up and initial training are carried out by trained staff of the Bizerba sales offices, customer service locations or by companies commissioned by Bizerba.

### **Bizerba is not responsible for damages caused by:**

- non-observance of operating conditions and operating instructions.
- defective electrical installation by the customer.
- structural changes to the devices.
- removal of verification seals and safety stamp marks.
- incorrect programming and operation.
- natural wear and tear.

### **The warranty will lapse, if:**

- defects/damages occur as a result of interventions by persons not authorized by Bizerba.
- any spare parts or operating material other than original Bizerba ones are used.
- any thermal ticket rolls and labels other than original Bizerba ones are used.
- Labels and thermal ticket rolls are used, which have not been manufactured to Bizerba specification or approved by Bizerba.

If you reset or program devices, check the new setting with a test run and test printout. This helps to avoid incorrect results.

Only trained staff may operate the devices.

Check that Bizerba products are handled correctly and repeat training if necessary.

Bizerba products undergo continuous further development and are subject to different country-specific regulations. Examples of pictures and graphics contained in these operating instructions may vary from the version which you received.

## 2.9 Disposal of devices/environmental protection



### **Only valid for Germany!**

**The application of the disposal regulations is based on legal regulations of the respective country.**

---

This device contains batteries which fall under the Batteries Act for the return and disposal of used batteries and accumulators.

This ordinance requires you, as the end user, to return the device to the manufacturer or dealer, at the end of its proper use, for the purposes of recycling and correct disposal.

Bizerba and its dealers are naturally willing to take back these defunct old devices.

Please contact your specialist in these cases.

If your device contains a rechargeable battery, you are required by the Battery Ordinance to return the used battery to the dealer or the public return points provided for this purpose.

Naturally, Bizerba and its dealers will also take back the used batteries.



**⚠ CAUTION**

**Risk of explosion if batteries are not replaced properly.  
Please follow the manufacturer's instructions when disposing  
of used batteries.**

## 3 Safety instructions

The safety instructions must be observed throughout the installation, operation, cleaning and maintenance procedures.

### 3.1 Requirements for operating personnel

The device must only be operated by personnel trained in the operation of this equipment. The operating personnel must read and understand the safety instructions in these operating instructions.

Please pay special attention to and memorize all safety and hazard information! Carry out regular training!

Operators (purchasers) as well as supervisory and operating staff must carry out programming and data protection on Bizerba systems and devices exclusively in accordance with the Bizerba operating and programming instructions.

Only use equipment for its intended purpose.

### 3.2 Operational safety

This device was developed and manufactured based on the latest technical know-how. However, personal injury, material damage or environmental damage can occur if the device is not properly used. Relevant warnings in these instructions make users aware of these residual risks.



Shut down equipment immediately in the event of recurring faults, damage of any type, and suspicion of risk of injury.

Inform Bizerba Service.

---

#### 3.2.1 Electricity

Connecting the wrong supply voltage can damage electrical components and the device can catch fire.

When opening the device, live wires could be freely accessible and the user could suffer an electric shock.

- ⇒ Compare the data of the supply voltage with the specifications on the identification plate of the plug-in power supply unit.
- ⇒ First, the mains data has to match the connection values of the scale. Only then you may connect the device to the power supply.
- ⇒ Opening the device must be carried out by trained and qualified Bizerba personnel only.
- ⇒ Disconnect device from supply voltage, battery pack or battery voltage before opening the device.

#### 3.2.2 Cleaning

Device could get damaged as a result of water penetrating the device or the use of wrong cleaning agents.

- ⇒ Make sure that water cannot penetrate the device during cleaning.
- ⇒ Do not use any alcohol, acetone or aggressive cleaning agents or abrasive cleaners.

### 3.3 System-related sources of hazards

	<p><b>⚠ WARNING</b></p>
	<p><b>Wrong supply voltage!</b>  <b>Destruction of electrical components, risk of fire</b></p> <ul style="list-style-type: none"> <li>– Compare the data of the supply voltage with the specifications on the identification plate of the plug-in power supply unit.</li> <li>– Only connect device to power supply if mains data matches the connection values of the scale.</li> </ul>

	<p><b>Check before connecting to mains!</b></p> <ul style="list-style-type: none"> <li>– Before connecting the device, check</li> <li>– mains data on identification plate.</li> <li>– mains data of the mains supply.</li> </ul>
---	---

	<p><b>⚠ CAUTION</b></p>
	<p><b>Switched-off device energized</b>  <b>Even when the device is switched off, the electronics is energized.</b></p> <ul style="list-style-type: none"> <li>– Pull out the power plug to de-energize the device.</li> </ul>

	<p><b>⚠ WARNING</b></p>
	<p><b>Opening the device!</b></p> <ul style="list-style-type: none"> <li>– Opening the device must be carried out by trained and qualified Bizerba personnel only.</li> </ul>

## 4 Installation

### 4.1 Transport and storage

Always transport and store the device in its original packaging.

### 4.2 Installation and assembly



- Installation, first commissioning, adjustment, initial instruction, maintenance and repair work may only be performed by our customer service and/or by companies or persons authorized by us.

---

#### 4.2.1 Requirements to the place of installation

The place of installation must fulfill the following conditions:

- Installation surface must be level.
- Make sure to install the device in a dry place free from vibrations, oscillation and protected from drafts.
- Set up devices based on operation, work flow and maintenance aspects.
- In order to prevent unacceptable heating, there must be free air convection around the scale.

#### Scale in mobile operation

In mobile operation the scale might be exposed to other outer conditions as compared to closed rooms such as wind, vibrations etc.

- ⇒ When transporting the scale in a transport vehicle, scale must be standing on foot screws, be tilt and slip-proof.
- ⇒ Place scale on even and stable floor space.
- ⇒ Place scale horizontally by adjusting the foot screws using the spirit level. [▶ 16]
- ⇒ Operate scale with mains connection or batteries. For battery operation, batteries should be fully charged.
- ⇒ If the display is unstable in case of wind or vibrations, adjust the sensitivity of the scale in menu Pr533. [▶ 33]
- ⇒ Protect scale from moisture, rain and direct sunlight.

#### 4.2.2 Unpacking

- ⇒ Open packaging, remove accessories and lift the device carefully out of the packaging.

### 4.2.3 Leveling of scale

In order to compensate for any small irregularities in the floor space, the scale can be leveled with the help of the spirit level and by adjusting the foot screws.

- ① Spirit level
- ② Foot screws

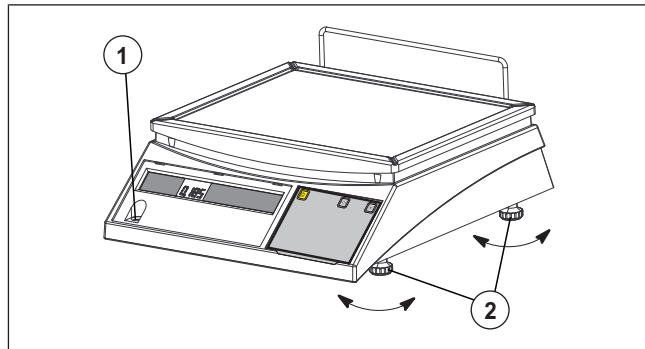
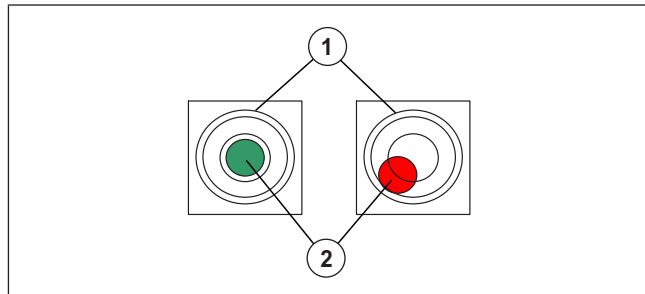

Illustration 3: Leveling

⇒ Turn foot screws until air bubble ② is located in the center of the spirit level ①.



– Re-level the scale after each change of location.

### 4.3 Power supply

The scale can be supplied with power in different ways:

- Mains voltage [▶ 16]
- Internal battery packs/batteries [▶ 18]
- External batteries [▶ 22]

#### 4.3.1 Mains connection

	<b>⚠ WARNING</b>
	<p><b>Wrong supply voltage!</b>  <b>Destruction of electrical components, risk of fire</b></p> <ul style="list-style-type: none"> <li>– Compare the data of the supply voltage with the specifications on the identification plate of the plug-in power supply unit.</li> <li>– Only connect device to power supply if mains data matches the connection values of the scale.</li> </ul>



## Installation of power supply provided by customer

The installation of the power supply for connecting to our equipment must be carried out in accordance with the international specifications and the regulations derived from them. These essentially include the recommendations of at least one of the following commissions:

- International Electro-technical Commission (IEC)
- European Committee for Electro-technical Standardization (CENELEC)
- German Association for Electrical, Electronic and Information Technologies (VDE)

### Check before mains connection

Our devices are built according to VDE protection III (extra-low voltage) and must be connected to a plug-in power supply unit with extra-low voltage.

#### Plug-in power supply units:



- Make sure that the scale is supplied via a listed plug-in power supply unit with identification class 2 and that electrical ratings are shown on the identification plate.

### Connect plug-in power supply unit

The plug-in power supply unit EC II 100 C is supplied with a connecting cable which is 5m long.



- Secure power cable from falling out by means of strain relief.

- ① Strain relief
- ② Connection:  
Cable connector from plug-in power supply unit  
**or**  
connecting cable from external battery pack

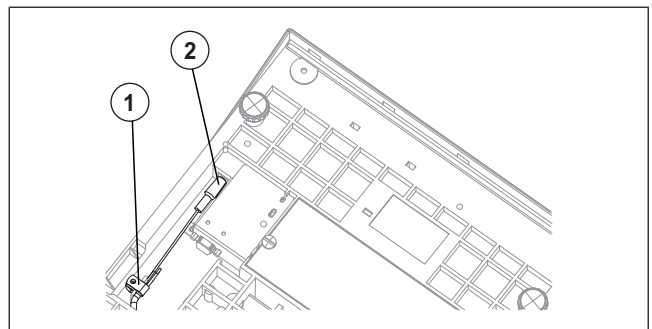

Illustration 4: Cable connector

- ⇒ Insert cable connector from plug-in power supply unit at bottom side of the scale ②.
- ⇒ Protect cable connector from falling out or being pulled out with the strain relief ①.

⇒ Insert plug-in power supply unit ①.

When connecting the plug-in power supply unit to the mains supply, the scale starts with the display test.

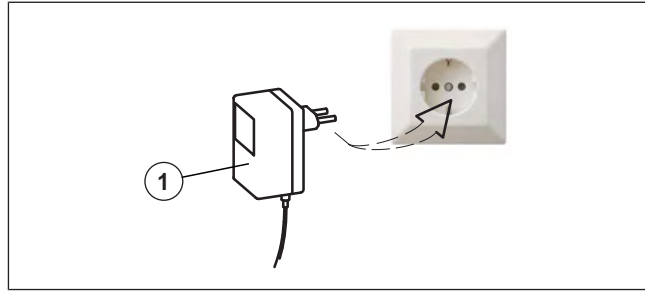

Illustration 5: Plug-in power supply unit

### 4.3.2 Battery pack/battery

The scale can be battery-operated.

With fully charged battery pack/batteries:

- approx. 120 hours if display illumination is switched off.
- approx. 70 hours if display illumination is switched on.



**The scale can be programmed in such a way that it switches off when not in use. This means that the scale can be battery-operated for longer.**

The switch-off time can be set to a value between 1 and 99 minutes (menu setting Pr531 [▶ 32]).

- Switch scale on again with <ON/OFF>, [▶ 26].



**Disposal of battery packs/batteries [▶ 11].**

### Insert battery packs/batteries

<b>NOTICE</b>	
	<p><b>Device damage due to reverse polarity of battery packs/batteries</b></p> <ul style="list-style-type: none"> <li>– When inserting the batteries, make sure to use correct position. The symbols + and - are shown on the base of the battery compartment and on the batteries.</li> <li>– Make sure that the position of these symbols matches.</li> </ul>

The battery compartment is located at the bottom of the scale and is protected by means of a cover which is screwed on.

- ⇒ Unplug plug-in power supply unit ① in order to separate the scale from the mains.

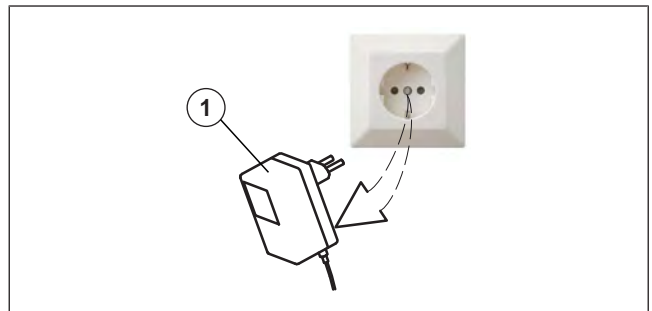

Illustration 6: Plug-in power supply unit

- ⇒ Remove load platter ②.

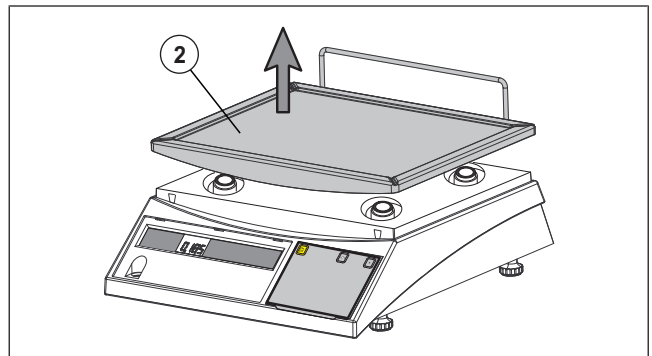

Illustration 7: Scale

- ⇒ Turn over the scale.  
The battery compartment is accessible from the bottom of the scale (cover ③).
- ⇒ Remove screw ④ from cover and remove cover ③.

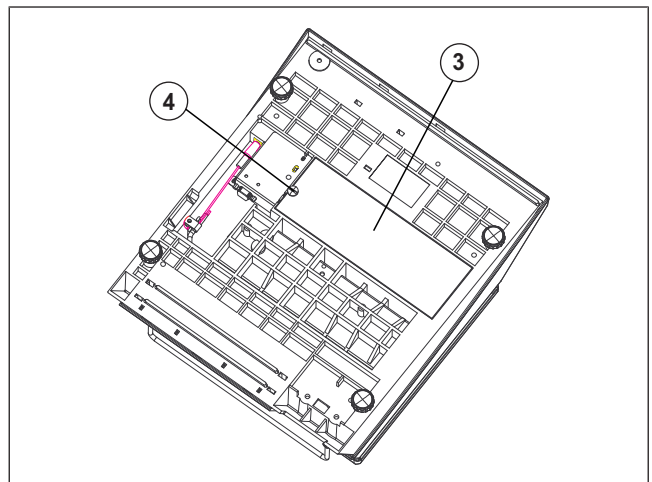

Illustration 8: Bottom of scale

- ➔ Insert battery packs/batteries according to symbols in the battery compartment ⑤ and pay attention to correct +- polarity.
- ➔ Close battery compartment in reverse order.

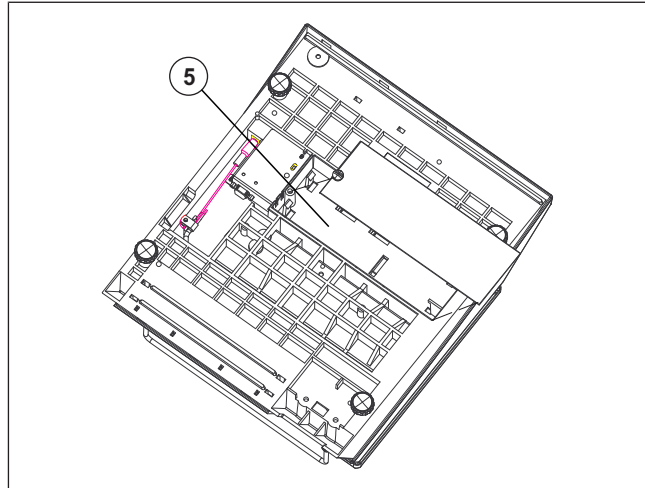

Illustration 9: Battery compartment

- ➔ Check switch ⑥ before switching the scale on:
  - When using battery packs, the switch must be set to "NIMH" ⑦. The switch is set to "NIMH" if the sticker ⑧ is not destroyed.
  - When using batteries, the switch must be set to "Battery" ⑨.

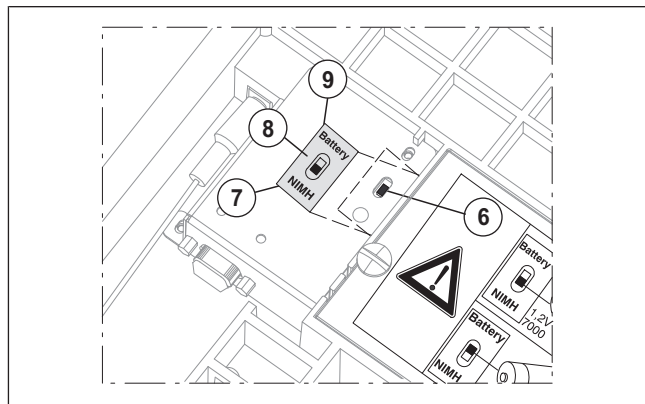

Illustration 10: Switch

	⚠ <b>WARNING</b>
<p style="margin: 0;"><b>Switch NIMH battery pack or battery incorrectly set</b></p> <p style="margin: 0;"><b>Batteries can explode.</b></p> <ul style="list-style-type: none"> <li>– Set switch to "Battery" if batteries are being used.</li> </ul>	

	<table border="1" style="width: 100%; border-collapse: collapse;"> <tr> <td style="text-align: center; font-size: small;">Battery</td> <td style="text-align: center;">   <small>NIMH</small> </td> <td style="text-align: center;">   <small>1,2V NIMH 7000 mAh Size D</small> </td> </tr> <tr> <td style="text-align: center; font-size: small;">Battery</td> <td style="text-align: center;">   <small>NIMH</small> </td> <td style="text-align: center;">   <small>1,5V Battery</small> </td> </tr> </table>	Battery	 <small>NIMH</small>	 <small>1,2V NIMH 7000 mAh Size D</small>	Battery	 <small>NIMH</small>	 <small>1,5V Battery</small>	<p style="margin: 0; font-weight: bold; font-size: small;">WARNING! Explosionsgefahr.</p> <p style="margin: 0; font-size: x-small;">Nur NiMH Akkus verwenden. Schalterstellung bei Verwendung von Batterien beachten.</p> <p style="margin: 0; font-weight: bold; font-size: small;">WARNING! Risk of Explosion!</p> <p style="margin: 0; font-size: x-small;">Use only NiMH rechargeable batteries. Make sure that the switch is in the right position for battery use.</p> <p style="margin: 0; font-weight: bold; font-size: small;">AVVERTENZA! Pericolo d'esplosione.</p> <p style="margin: 0; font-size: x-small;">Usare solo accumulatori NiMH. Fare attenzione alla corretta posizione dell'interruttore durante l'uso con batteria.</p> <p style="margin: 0; font-weight: bold; font-size: small;">AVERTISSEMENT! Danger d'explosion.</p> <p style="margin: 0; font-size: x-small;">Utiliser seulement des accumulateurs NiMH. Faire attention à la position correcte du commutateur en cas d'utilisation de batteries.</p> <p style="margin: 0; font-weight: bold; font-size: small;">¡ADVERTENCIA! ¡Peligro de explosión.</p> <p style="margin: 0; font-size: x-small;">¡Utilizar sólo acumuladores NiMH. ¡Observe la posición correcta del conmutador en caso de utilizar baterías.</p>
Battery	 <small>NIMH</small>	 <small>1,2V NIMH 7000 mAh Size D</small>						
Battery	 <small>NIMH</small>	 <small>1,5V Battery</small>						

## Operation using rechargeable batteries

The battery pack discharges even while not in use for a longer period of time if the scale is not connected to the power supply. Therefore, the scale should be connected to the mains supply every 3 months at the latest.

When the scale is working in mains operation, the battery packs are only recharged while the scale is switched on (trickle charging).

Overloading the batteries is prevented automatically by an integrated charging circuit. This charging circuit also prevents any damaging total discharge. The battery lifetime reduces if it is permanently operated at an almost discharged state.

	<b>⚠ WARNING</b>
	<p><b>Use of normal batteries or wrong battery packs</b></p> <p><b>Batteries may explode or leak</b></p> <ul style="list-style-type: none"> <li>– Only use NIMH battery packs 7000 mAh 1.2 V (6 per device) with the same rated storage capacity.</li> <li>– Only install battery packs from the same manufacturer, type and age.</li> <li>– Only use leakproof battery packs.</li> </ul>



### Battery pack lifetime

Battery packs have a limited lifetime. As a result the capacity of the batteries decreases, as does the serviceable life of the scale in rechargeable battery operation.

- Insert new battery packs in order to achieve full power of the scale in battery operation.

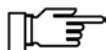

### Battery charging functions

The rechargeable batteries are charged during mains operation, but only when the scale is switched on. There are 2 charging functions for charging the battery packs in the scale. These can be selected in menu Pr532:

#### Loading new battery packs





In case of new battery packs, a trickle charge of 16 hours must be carried out two times [▶ 32].

Option automatic charging is active again after each trickle charge.

#### Automatic charging

The batteries are automatically charged through internal measurement of the charging condition in the scale.

### Battery symbol display

- ⑥ Battery pack symbol
-  Battery operation / battery charging in order.
-  flashing slowly:  
mains operation / batteries are being charged
-  flashing quickly:  
Warning, batteries require charging.  
(Depending on the age of the battery packs and the ambient temperature, it is possible to continue operation for about 10 to 120 minutes).
-  flashing very quickly  
Battery voltage too low, scale will continue to operate for a short time.  
Warning "ACCU LO" appears in the display, then the scale switches off.
- Battery symbol not visible:  
Scale on mains / batteries are charged

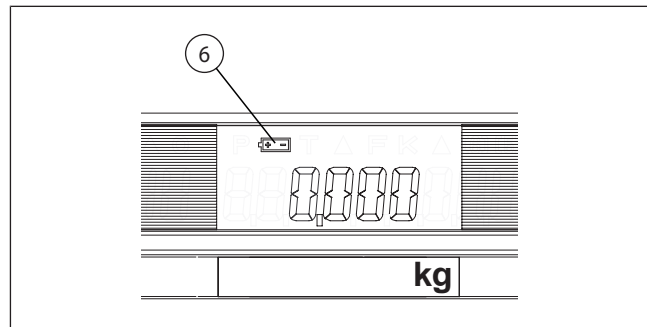

Illustration 11: Display

### Operation with mains and battery pack

	<b>CAUTION</b>
	<p><b>Use of wrong plug-in power supply unit damages the scale.</b></p> <ul style="list-style-type: none"> <li>– Make sure that data of plug-in power supply unit matches the data on the type plate of the scale.</li> </ul>

- ⇒ Insert plug-in power supply unit ①
- The scale is supplied via the mains while batteries are being charged.
- In the event of failure of the mains supply, the scale automatically switches to rechargeable battery operation and back to mains supply as soon as the mains power supply is restored.

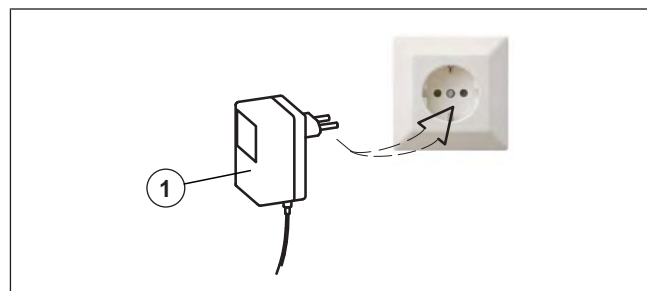



Illustration 12: Plug-in power supply unit

#### 4.3.3 External 12V battery operation (optional)

The scale can be optionally operated with an external battery pack. To do this, the external battery is connected to the power supply input via a connection cable.

The power source (external battery) must meet the requirements of the power limit in accordance with UL 60950 and IEC 60950-1: 2001, paragraph 2.5.

## Connection example

- ⑨ Connection cable   
The connection (limited power source) must have 4 A which is to be provided by customer.

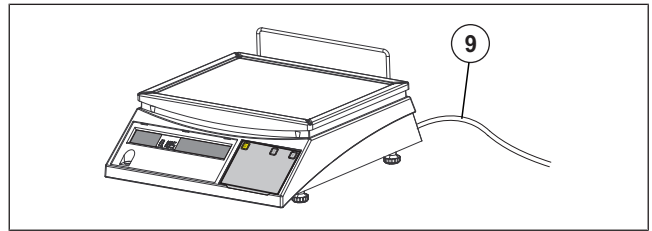

Illustration 13: Connection cable

- ⑩ Connection:  
Cable connector from plug-in power supply unit  
**or**  
connecting cable from external battery pack

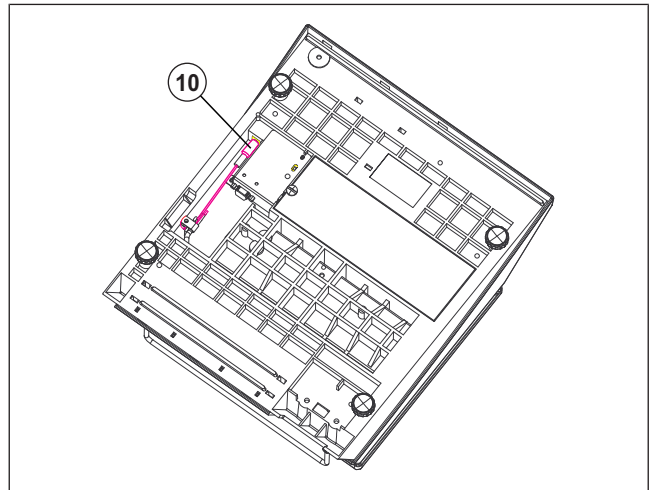

Illustration 14: Scale connection

## Convert from mains operation to external battery operation Convert

- ⇒ Disconnect cable from plug-in power supply unit at bottom side of the scale ⑩.
- ⇒ Attach connecting cable to a 12V outlet.
- ⇒ Attach connecting cable to the bottom of the scale ⑩.

## Convert from external battery operation to mains operation Convert

- ⇒ Unplug connecting cable at bottom of the scale ⑩.
- ⇒ Insert cable with plug-in power supply unit at bottom side of the scale ⑩.
- ⇒ Insert plug-in power supply unit in outlet.

## 4.4 Decommissioning

- ⇒ To put the scale out of operation for a prolonged period of time, remove the cable connector from the plug-in power supply unit at the bottom of the scale.
- ⇒ Remove battery packs or batteries from the battery compartment.
- ⇒ Clean the scale according to the cleaning instructions.

## 5 Device and operating controls

### 5.1 Display

The display is divided as follows:

- ① Weight value
- ② Symbols

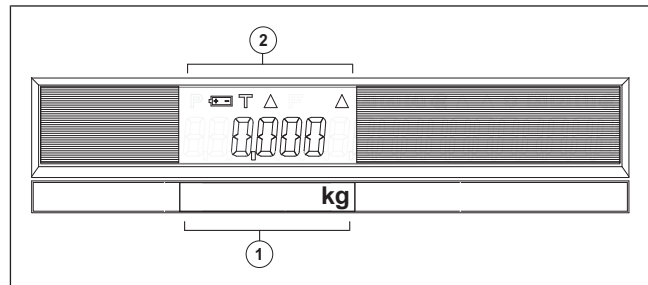

Illustration 15: Display EC II 100 E

### 5.2 Keyboard



**Keyboard designs are country-dependent.**

#### 5.2.1 Membrane keyboard

The membrane keyboard has a transparent insert where the keyboard labeling can be inserted if required.

- ① Membrane keyboard
- ② Keyboard labeling

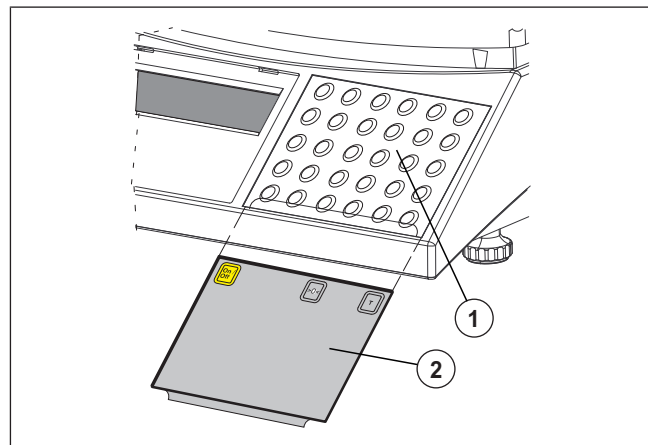





Illustration 16: Membrane keyboard



## 5.2.2 Key functions

- ③  Switches the scale on / off
- ④  Switches the scale on / off
- ⑤  Taring

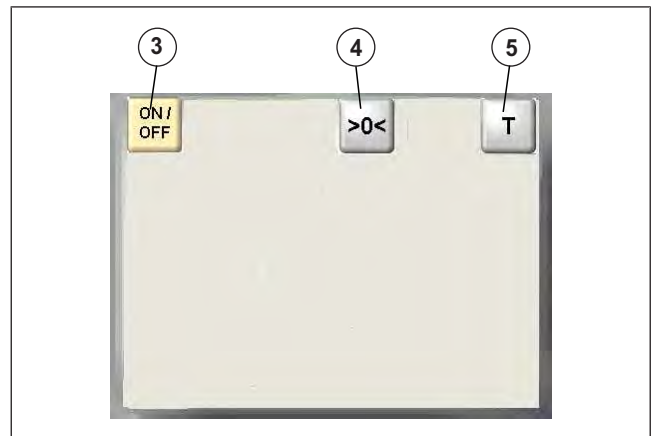

Illustration 17: Keyboard labeling

## 5.2.3 Scale without keys (control scale)

The control scale does not have any keys.



- To switch the control scale on and off, connect or disconnect plug-in power supply unit.

- ① Control scale cover

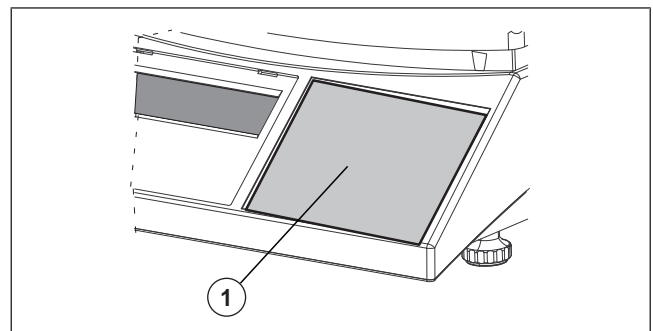





Illustration 18: Keyboard cover

## 6 Operation

### 6.1 Switching scale on, off and zero setting

- ①  ON/OFF button
- ②  Zero setting key
- ③  Tare key

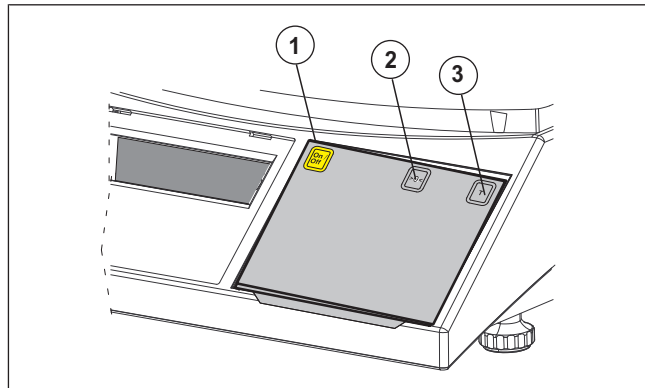

Illustration 19: Keyboard

#### 6.1.1 Switch-on

##### Control scale EC II 100 C

- ⇒ Make sure that scale is unloaded.
- ⇒ Insert plug-in power supply unit.

The display is tested automatically. All digits and symbols are displayed for approx. 5 sec.

Afterwards, the weight display automatically goes to "0.000" kg when unloaded and the scale is ready for operation.

##### Scale EC II 100 E

The <ON/OFF> key can be activated or deactivated (setting [▶ 32]).

- ⇒ Make sure that scale is unloaded.

-  If <ON/OFF> is activated, press <ON/OFF> until you hear a signal.
- If <ON/OFF> is deactivated, insert the plug-in power supply unit.

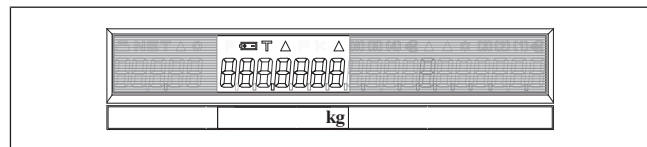

The display is tested automatically. All digits and symbols are displayed for approx. 5 sec.

Afterwards, the weight display automatically goes to "0.000" kg when unloaded and the scale is ready for operation.

#### 6.1.2 Switch off

Unintentional switch off of the scale is not possible.

##### Control scale EC II 100 C

- ⇒ Disconnect plug-in power supply unit.

## Scale EC II 100 E



Press and hold <ON/OFF> until display turns dark.

The scale counts backwards "OFF 3"- 2- 1.

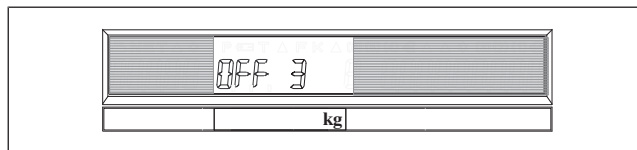

The display then goes dark and the scale is switched off.

If the key is released too soon, the scale will start the display test again.

### 6.1.3 Zero setting

The scale has an automatic zero setting device.

Minor zero point changes are compensated automatically.

After switching the scale on, the weight display is automatically set to "0.000" kg provided that the scale is unloaded.

The weight display can (if the display is not set to zero) be reset again with the scale unloaded.

#### Example

After switching on, the display does not indicate zero.

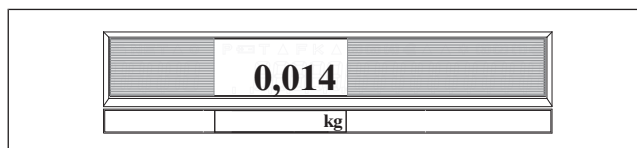

Press <Zero setting>.

The display indicates zero.

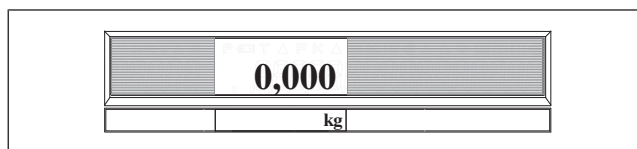

## 6.2 Tare functions

Taring sets the scale display to "0" regardless of the load. The available weighing range for the EC II 100E is reduced by the amount of the tare load (subtractive tare).

### 6.2.1 Tare balancing for unknown tare values



**An unknown tare weight ( empties) is a non-article related tare which is to be weighed and tared.**

Scales with a weighing range below 10 kg allow the full range to be tared.

For scales with a weighing range above 10 kg, taring of up to 9.995 kg max (max. 4 digits) is possible (depending on country).

The tared value is subtracted from the total weighing range.

The tare command is only directly executed when the weight display is stationary.

### Taring with unknown tare

Weigh article in an empty (tare) with the weight unknown.

- ⇒ Place empties on the scales.

The weight display ① indicates the weight of the empty container, e.g.: "0.535" kg.

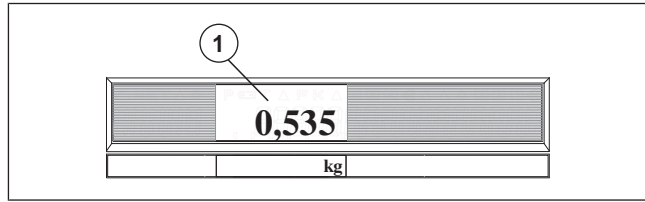

Illustration 20: Unknown tare



Press <Tare>.

The tare value is adopted. Symbol "△" ② indicates that the tare was adopted.

The weight display ① indicates "0.000" kg.

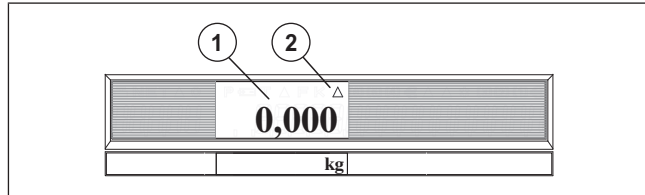

- ⇒ Fill product into empty container.

The weight display ① indicates the net weight of the article "2.000" kg.

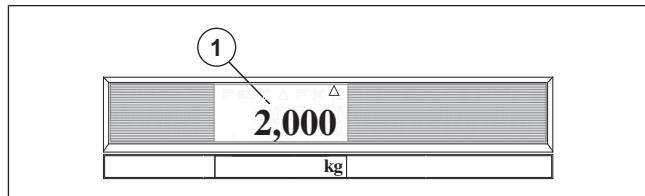

### Batch tare (country-related)

Determine unknown tare, weigh article, re-tare and weigh next article net.

- ⇒ Place empties on the scales.

The weight display ① indicates the weight of the empty container, e.g.: "0.535" kg.

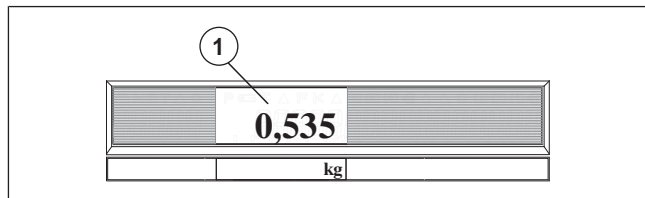

Press <Tare>.

The tare value is adopted. Symbol "△" ② indicates that the tare was adopted.

The weight display ① indicates "0.000" kg.

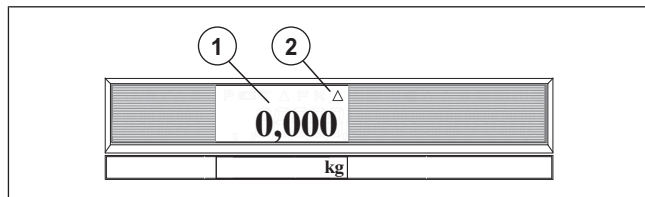

Fill product into empty container.

The weight display ① indicates the net weight of the article "0.800" kg.

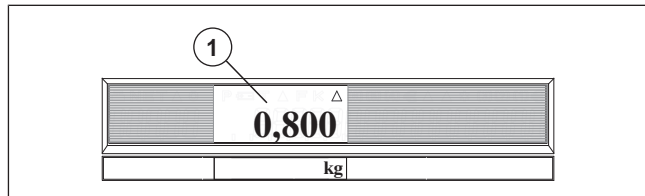



Press <Tare>. Article and empty weight are tared <sup>②</sup>. The weight display <sup>①</sup> indicates "0.000" kg.

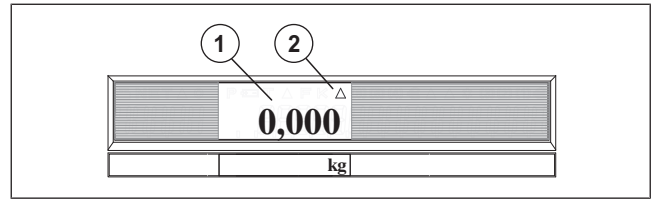

The complete weighing range can be used for tare for scales below 10kg.

### Deleting tare

⇒ Unload scale.



Press <Tare>. Symbol "△" is no longer displayed. The weight display <sup>①</sup> indicates "0.000" kg.

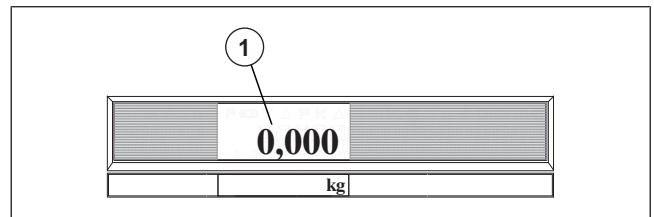

## 6.3 Programming



– Have menus adjusted by our sales offices and customer service departments or companies authorized by us.

- ① Key <Clear>
- ② Keys <0> to <9> (10-key keypad)
- ③ Keys <10>, <11>, <12>
- ④ Key <ON/OFF>
- ⑤ Key <Mod>
- ⑥ Key <Fix>

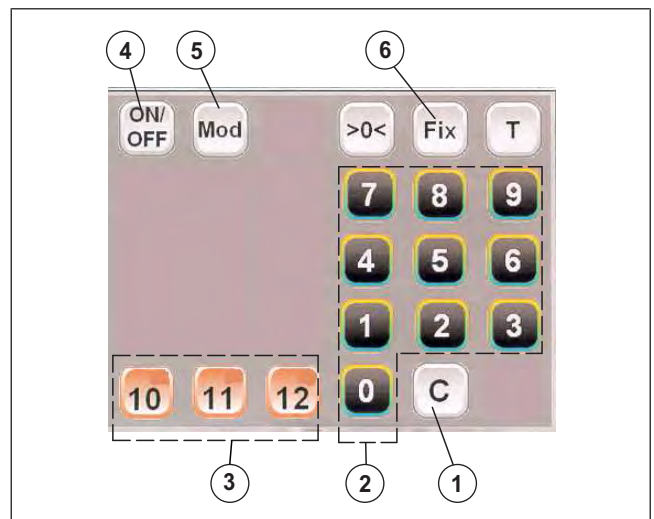

Illustration 21: Programming keys

### 6.3.1 Activate menu input

The menu input can only be activated during switch-on.



Press and hold <ON/OFF> until display turns dark.



Press <ON/OFF>. The display is tested automatically.



During the display test press keys <10>, <11> and <12> one after another.

No beep should be heard when the keys are pressed.

### 6.3.2 Menu call-up, menu selection and escape menu

- ① Input field for menu selection
- ② Input field for functions

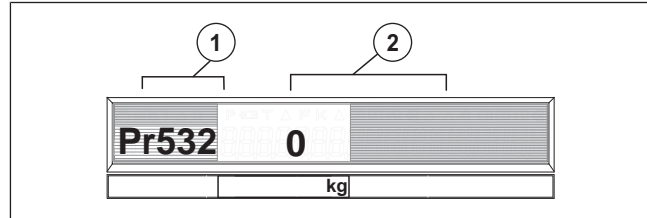

Illustration 22: Programming display

### 6.3.3 General programming sequence

#### Menu call-up



Call up menu.

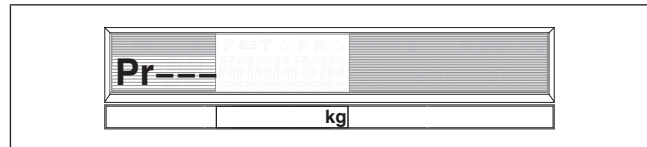

#### Select menu



Select menu.

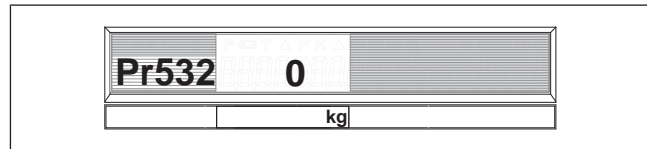

#### Make setting



e.g. set function <1>.

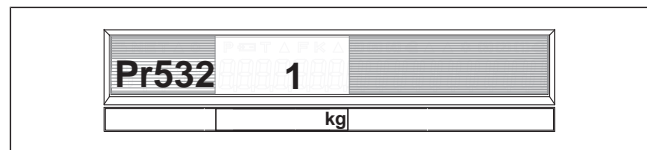

Confirm setting with <Fix>.

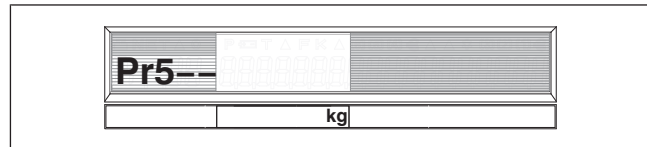

#### Exit menu



Exit menu.

The scale returns to the initial display.

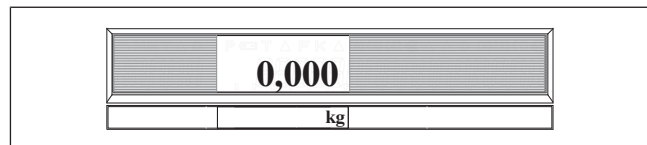

### 6.3.4 Programming overview

Configuration	Setting option		Menu	See page
<b>Activate/deactivate &lt;ON/OFF&gt;</b>	<b>2</b>	<ON/OFF> active	Pr501	[▶ 32]
	<b>3</b>	<ON/OFF> inactive		
<b>Turn-off function</b>	<b>00</b>	Scale is not turned off	Pr531	[▶ 32]
	<b>01-99</b>	Turn-off time after min.		
<b>Battery charging function</b>	<b>0</b>	No charging	Pr532	[▶ 32]
	<b>1</b>	Automatic charging		
	<b>2</b>	Trickle charging		
<b>Scale (display) sensitivity</b>	<b>0-9</b>		Pr533	[▶ 33]

Service personnel	Setting option		Menu	See page
<b>Load cell type Display</b>		<div style="border: 1px solid black; padding: 5px; display: inline-block;">Pr715 Cod 60201</div>	Pr715	[▶ 33]
<b>Logbook monitoring</b>		<div style="border: 1px solid black; padding: 5px; display: inline-block;">Pr730 0</div>	Pr730	[▶ 34]
<b>Turn-off function in mains operation</b>	<b>0</b>	Turn-off function during mains operation inactive.	Pr792	[▶ 36]
	<b>1</b>	Turn-off function active during mains operation		
<b>Turn-on time Power-saving mode (SLEEP)</b>	<b>03</b>	Time in minutes (0-99 min)	Pr793	[▶ 36]

### 6.3.5 Configuration menu Pr5 - -

#### Overview menu configuration

Deactivate <ON/OFF> key	Pr501
Turn-off function	Pr531
Battery charging function	Pr532
Scale (display) sensitivity	Pr533

## Deactivate <ON/OFF> key (Pr501)

- ① Input option:
- 1 Control scale EC II C. The keyboard is disabled. The <ON/OFF> key does not work.
  - 2 <ON/OFF>, <zero setting> and <T> are active.
  - 3 <ON/OFF> is deactivated. <Zero setting> and <T> are active.

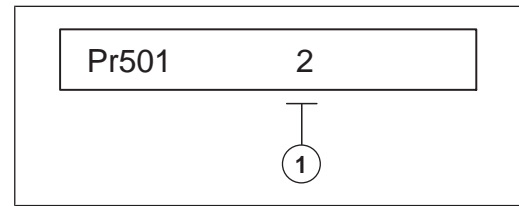

## Turn-off function (Pr531)

- ① Input option:
- 00 Scale is not turned off.
  - 01-99 Battery operation: Turn-off time in minutes, if no action occurs on the scale.  
Mains operation: Note setting in menu Pr792.

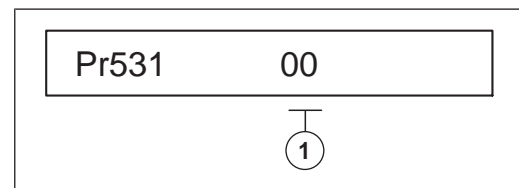

⇒ To turn the scale on after an automatic turn-off press <ON/OFF>.

If the turn-off time is set to > 10 min., the scale goes into power-saving mode after a time set in menu Pr793. "SLEEP" appears in the display.

⇒ To wake up the scale from the power-saving mode press any key.

After about 3 seconds the scale is ready for operation again.

## Battery charging function (Pr 532)

- ① Input option:
- 0 No charging.
  - 1 Automatic charging  
The charging condition of the batteries is measured in the scale and the batteries are automatically recharged as needed.
  - 2 Trickle charging for new batteries  
New batteries require two trickle charges of 16 hours each. Automatic charging is active again after each trickle charge.

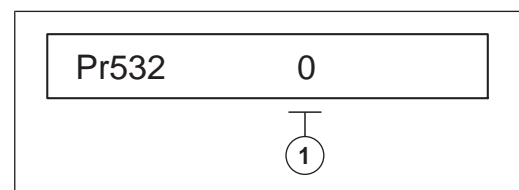



## Scale display sensitivity (Pr533)

The sensitivity setting regulates damping in the event of vibrations at the place of installation (e.g. for market operation).



**The higher the setting, the longer it takes until standstill of the display.**

① Input option:

**0** Display sensitive (standard) with stable, vibration-free scale floor area

01-99 Display increasingly insensitive

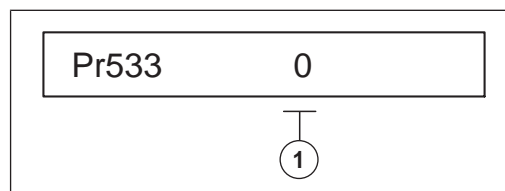

### 6.3.6 Service menu Pr 7- -

#### Overview service menu

Display the load cell type	Pr715
Logbook monitoring	Pr730
Activate/deactivate turn-off function in mains operation	Pr792
Switch-on period of power-saving mode (SLEEP)	Pr793

#### Display load cell type (Pr715)

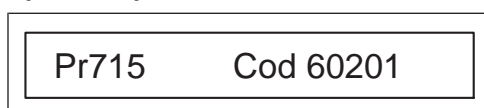

Illustration 23: Display example

Display	Load cell types	Load capacity	Interval
Cod 120201	WS18,WS36	12 kg	2 g
Cod 150501	WS18,WS36	15 kg	5 g
Cod 150502	WS18,WS36	6/15 kg	2/5 g
Cod 150503	WS18	6/15 kg	2/5 g
Cod 151501	WS18, WS12	15 lb	0.005 lb
Cod 150201	WS18	15 kg	2 g
Cod 252111	WS18	25 lb	1/8 oz
Cod 030011	WS36	30 kg	10 g
Cod 301111	WS18,WS36	30 lb	0.01 lb
Cod 301112	WS18,WS36	15/30 lb	0.005/0.01 lb

Display	Load cell types	Load capacity	Interval
Cod 301113	WS18	15/30 lb	0.005/0.01 lb
Cod 301501	WS18,WS36	30 lb	0.005 lb
Cod 300501	WS36	30 kg	5 g
Cod 300111	WS36	30 kg	10 g
Cod 300112	WS36	15/30 kg	5/10 g
Cod 300113	WS36	15/30 kg	5/10 g
Cod 060101	WS18, WS12	6 kg	1 g
Cod 060201	WS18, WS12,WS36	6 kg	2 g
Cod 060202	WS18, WS12	3/6 kg	1/2 g
Cod 060203	WS12	3/6 kg	1/2 g
Cod 601111	WS36	60 lb	0.01 lb
Cod 601211	WS36	60 lb	0.02 lb
Cod 601212	WS36	30/60 lb	0.01/0.02 lb

### Logbook monitoring (Pr730)

Information can be requested from the logbook in menu Pr730.

#### Logbook monitoring overview



Press <Fix> in order to display the software ID. (step 1)



Press the shift key to call up logbook entries. (step 2)

Each entry in the logbook is distributed on several displays which is respectively shown as a step.

Step	Display
21	Consecutive number of the logbook entry, department number, component number.
22	Version number of the loaded software.
23	Date and time of download.

#### Example: Invocation of logbook entries



<Press Mod>.

Pr---



Press <7>, <3> and <0> on the 10-key keypad.

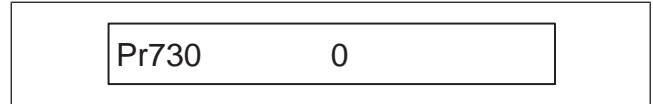

Press <Fix> in order to display the software ID (2). (step 1 (1))

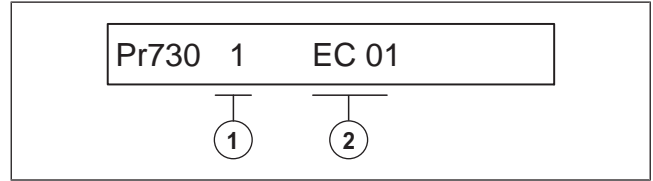

Press the shift key to call up logbook entries (step 2) and to call up further steps.

- ① Current number of entry
- ② Department number
- ③ Component number

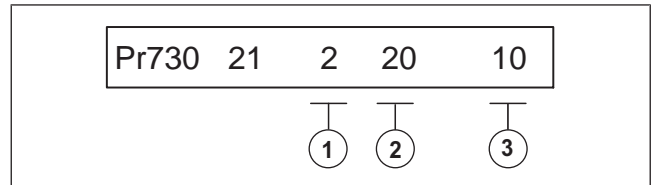

Illustration 24: Step 21

- ① Version number of the loaded software

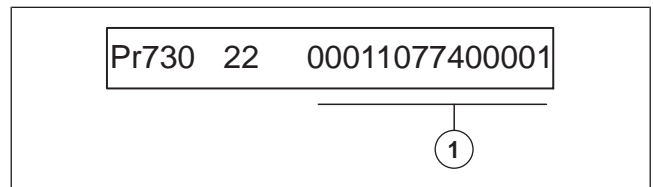

Illustration 25: Step 22

- ① Date
- ② Time

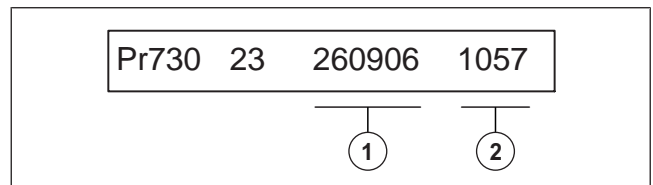

Illustration 26: Step 23



Press the shift key to display the next entry.

Repeat as often as needed until all entries were displayed.

If all entries have been displayed, the scale returns to the initial menu display.

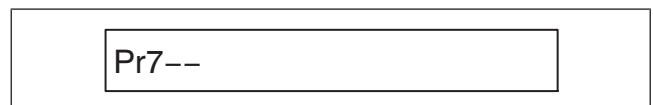

## Activate/deactivate turn-off function in mains operation (Pr792)

The turn-off function for mains operation is activated or deactivated in menu Pr792. (See also Pr531 [► 32].)

- ① Input option:
- 0 Turn-off function during mains operation inactive.
  - 1 Turn-off function during mains operation active.

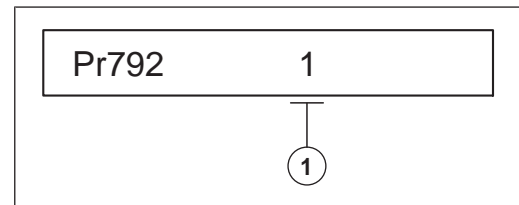

## Switch-on period of power-saving mode (SLEEP) (Pr793)

The time after which the scale is put into power-saving mode can be set in menu Pr793.

If a turn-off time >10 minutes is set in menu Pr 531, the ADC (analog digital converter) is put into power-saving mode after approx. 3 minutes as standard. (See also Pr531, [► 32].)

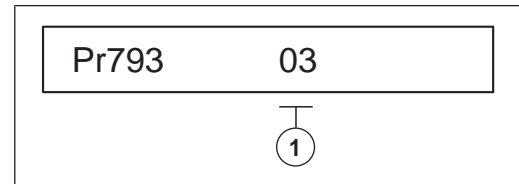

- ① Input option:
- 03 Time in minutes after which the scale goes into power-saving mode (00-99)



**If a time of 00 minutes is set or a time which is greater than the turn-off time in Pr531, power-saving mode will not be executed.**

## 7 Troubleshooting

### 7.1 Interference suppression

	 <b>WARNING</b>
	<p><b>Electric shock when working on the supply voltage</b></p> <ul style="list-style-type: none"> <li>– Work on the mains power supply may only be carried out by trained and qualified personnel.</li> </ul>

- ⇒ In case of electrical disturbances in the mains power supply, interference suppression devices must be installed by customer, e.g.:
  - Provision of separate mains cable to BIZERBA equipment.
  - In case of problems, the feeding lines to Bizerba devices should include a capacitive decoupled isolation transformer or some other interference suppressing device.

### 7.2 Error descriptions

Fault	Cause	Remedy
Display does not illuminate.	No supply voltage. No battery voltage or battery pack/battery empty.	<ul style="list-style-type: none"> <li>⇒ Check plug-in power supply unit and plug it in.</li> <li>⇒ Check connection plug-in power supply unit/connector connecting cable.</li> <li>⇒ Check battery pack/battery and charge, if needed.</li> <li>⇒ Press &lt;ON/OFF&gt;</li> </ul>
Weight value display not at zero or modified.	Load platter is incorrectly positioned or objects are touching the load platter. Soiling on or beneath the load plate. Scale not leveled.	<ul style="list-style-type: none"> <li>⇒ Clean load plate, position correctly and remove objects.</li> <li>⇒ Level scale.</li> <li>⇒ Switch scale off and on again.</li> </ul>

### 7.3 Error messages

Operating errors or faults in the electronic system are indicated by "Cod" and a code number.

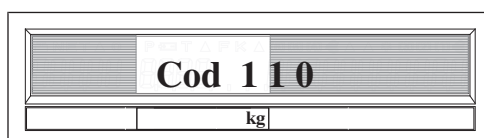

<b>Error message</b>	<b>Cause</b>	<b>Remedy</b>
Cod 112	Movement of the scale during start-up.	⇒ Do not move scale during switch-on! ⇒ Switch scale off and on again.
Cod 115	Scale is below zero.	⇒ Switch scale off and on again.
Cod 110	Scale loaded during start-up.	⇒ Unload scale. ⇒ Switch scale off and on again.
Cod110	Scale below zero during start-up.	⇒ Position load platter. ⇒ Switch scale off and on again.
Other error code digits	---	⇒ Switch scale off and on again.

## 8 Maintenance

### 8.1 Cleaning

Cleaning instructions must be observed during installation, operation and maintenance.

	<b>NOTICE</b>
	<p><b>Incorrect cleaning agents!</b>  <b>Damage of device surfaces.</b></p> <ul style="list-style-type: none"> <li>– Do not use spirit, acetone or aggressive cleaning or scouring agents.</li> </ul>

	<b>NOTICE</b>
	<p><b>Cleaning!</b>  <b>Damage due to water in the device.</b></p> <ul style="list-style-type: none"> <li>– make sure that no water runs into the device when cleaning.</li> <li>– Do not wash device off or spray-wash.</li> </ul>

Use warm water with dish-washing detergent (food safe) for cleaning. Use a soft, non-fraying cloth, moistened lightly. Use a properly wrung-out cloth. The cloth must be nearly dry.

#### **Remove dirt from beneath the load plate.**

- Switch device off and remove AC power plug.
- Remove load platter.
- Remove loose dirt with a brush or a vacuum cleaner.
- Position load platter.
- Plug in power pack

### 8.2 Maintenance

- ⇒ Remove loose dirt under load platter every 4 weeks. To do this, remove the load plate and remove loose dirt with a brush or vacuum cleaner.
- ⇒ Replace the load plate and check the zero point of the scale. Switch the scale off and on if necessary.

#### **Testing the weight display**

- ⇒ After each cleaning, place a reference weight of 2x3 kg on the scale and check whether the display shows 3 or 6kg.

## 9 Technical data

### 9.1 Dimensions

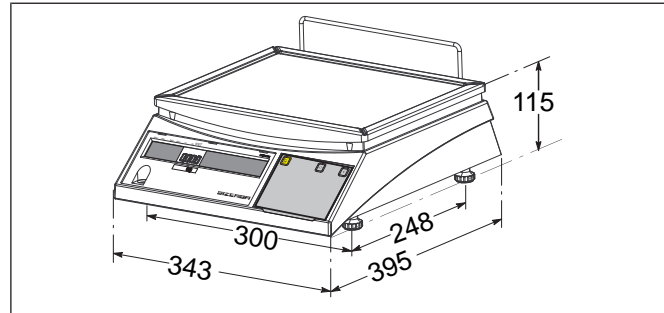

Illustration 27: Scale housing dimensions

### 9.2 Power supply

### 9.3 Special ambient conditions

- ⇒ When applying electronic retail scales, weighing and EDP systems, recording units and similar devices, device combinations and spare parts the following requirements must be strictly observed.

For other manufacturers' equipment included in our scope of supply, the respective manufacturer's regulations take preference if they deviate from our conditions.



## Subject index

### A

Ambient conditions 40

### B

Battery operation  
     External 22, 23  
 Battery pack 18  
     Charging function 21  
     Lifetime 21  
     Module 7  
     Replace 18  
     Symbol display 22

### C

Cleaning 39  
 Conditions at place of installation 15  
 Configuration 31

### D

Declaration of conformity 44  
 Decommissioning 23  
 Dimensions 40  
 Directives 9  
 Display 24  
 Disposal 11  
 Document description 5

### E

Environmental protection 11  
 Error descriptions 37  
 Error messages 37

### I

Installation 15  
 Interference suppression 37

### K

Kennzeichnungsschild 7  
 Key  
     ON/OFF 26  
 Keyboard 24

### L

Legend 5  
 Leveling of scale 16

### M

Mains connection 16  
 Mains operation 23  
 Maintenance 39  
 Membrane keyboard 24  
 Menu  
     Call-up 30  
     Escape 30  
     Select 30  
 Mobile operation 15

### O

Operating conditions 10  
     Modifications, spare parts 11  
     Start-up, operation 10  
 Operating safety 13  
 Operation  
     with battery pack 20  
     With mains and battery pack 22  
 Operational safety 13  
 Option 7

### P

Place of installation 15  
 Plug-in power supply unit  
     Connect 17  
 Plug-in power supply units 17  
 Power supply 40  
 Programming overview 31

### S

Safety instructions 13  
 Scale in mobile operation 15  
 Settings 31  
 Standards 9  
 Storage  
     Device 15  
 Supply voltage 14, 16  
 Switch off 26  
 Switch-on 26  
 Symbols 5

---

T	
Tare	27
Batch tare	28
unknown tare	28
Tastatur	
Funktionen	25
Taste	
ON/OFF	25
Transport	15
Typenschild	7
V	
Verification	9
Verification information	9
W	
Warnings	6, 14
Warranty	11
Z	
Zero setting	27

# 10 **Annexe**

Bizerba GmbH & Co. KG  
Wilhelm-Kraut-Straße 65  
72336 Balingen, Germany

# BIZERBA



## Declaration of conformity

valid until 4/19/2016

We herewith declare that the materials used for the following non-automatic scale

<b>Designation:</b>	Retail scale
<b>Type:</b>	EC II. . .
<b>No. of EC type approval:</b>	D06-09-026
<b>No. of appointed body for the EC type approval:</b>	0102 (PTB)

complies with the type described in the type approval certificate and the current requirements of the following EC directives:

Directive on non-automatic weighing instruments	2009/23/EG
EMC directive on electromagnetic compatibility	2004/108/EG
Directive on electrical equipment designed for use within certain voltage limits	2006/95/EG

Harmonized standards and technical specifications applied:

<b>Metrology:</b>	DIN EN 45501:1992 (OIML R76-1, 2006)
<b>EMC:</b>	DIN EN 61000-6-1/2007-10; DIN EN 55022/ 2011-12 DIN EN 61000-3-2/2010-03; DIN EN 61000-3-3/ 2014-03
<b>Safety:</b>	DIN EN 60950-1

**The Declaration of Conformity only applies with regard to the EC Scales Guideline in conjunction with a conformity certification from an appointed body.**

This sentence is omitted when the conformity evaluation has been carried out by Bizerba.

The declaration of type conformity is based on contractual documents (Bizerba order documents). Any modification made to the above device type without the prior permission of Bizerba or by Bizerba staff will render this declaration invalid.

Date: 02/15/2016

Signature of manufacturer:

By proxy

  
Sebastian Richter

Title of signatory:

Director Retail Systems Technology

Bizerba GmbH & Co. KG

Bizerba GmbH & Co. KG  
Wilhelm-Kraut-Straße 65  
72336 Balingen, Germany

# BIZERBA



## EU declaration of conformity

Valid from 4/20/2016

We herewith declare that the device indicated hereafter conforms to the specified applicable requirements and the requirements set out in EU legislation.

Device type:	Non-automatic, elektromechanical scale
Model:	EC II 100 / EC II 100 C / EC II 100 CD / EC II 100 E / EC II 200 F

Approval for this device type:

Type:	EC II...
Number of EC type-approval:	D06-09-026
Identification no. of notified body for EU type-approval:	0102 Physikalisch-Technische Bundesanstalt (PTB)

EU legislation:

Non-automatic weighing instruments:	2014/31/EU; Official Journal of the EU issued on 29.03.2014 L96 pp. 107-148
EMC:	2014/30/EU; Official Journal of the EU issued on 29.03.2014 L96 pp. 79-106
Low voltage:	2014/35/EU; Official Journal of the EU issued on 29.03.2014 L96 pp. 357-374

Harmonized standards and technical specifications applied:

Metrology:	EN 45501:2015; OIML R76-1, 2006
EMC:	EN 61000-6-1:2007; EN 55022:2010 EN 61000-3-2:2006 + A1:2009 + A2:2009; EN 61000-3-3:2013
Electrical safety:	EN 60950-1

The declaration of type conformity is based on contractual documents (Bizerba order documents). Any modification made to the above device type without the prior permission of Bizerba or by Bizerba staff will render this declaration invalid.

Date: 02/15/2016

Signature of manufacturer:

By proxy

Sebastian Richter

Title of signatory:

Director Retail Systems Technology

Bizerba GmbH & Co. KG