

USER MANUAL

MY3

CUSTOM  *M*[®]

CUSTOM S.p.A.
Via Berettine 2/B
43010 Fontevivo (PARMA) - Italy
Tel. : +39 0521-680111
Fax : +39 0521-610701
http: www.custom.biz

Customer Service Department:
Email : support@custom.it

© 2015 CUSTOM S.p.A. – Italy.
All rights reserved. Total or partial reproduction of this manual in whatever form, whether by printed or electronic means, is forbidden. While guaranteeing that the information contained in it has been carefully checked, CUSTOM S.p.A. and other entities utilized in the realization of this manual bear no responsibility for how the manual is used. Information regarding any errors found in it or suggestions on how it could be improved are appreciated. Since products are subject to continuous check and improvement, CUSTOM S.p.A. reserves the right to make changes in information contained in this manual without prior notification.

The pre-installed multimedia contents are protected from Copyright CUSTOM S.p.A. Other company and product names mentioned herein may be trademarks of their respective companies. Mention of third-party products is for informational purposes only and constitutes neither an endorsement nor a recommendation. CUSTOM S.p.A. assumes no responsibility with regard to the performance or use of these products.

THE IMAGES USED IN THIS MANUAL ARE USED AS AN ILLUSTRATIVE EXAMPLES. THEY COULDN'T REPRODUCE THE DESCRIBED MODEL FAITHFULLY.

UNLESS OTHERWISE SPECIFIED, THE INFORMATION GIVEN IN THIS MANUAL ARE REFERRED TO ALL MODELS IN PRODUCTION AT THE ISSUE DATE OF THIS DOCUMENT.

GENERAL INSTRUCTIONS

CUSTOM S.p.A. declines all responsibility for accidents or damage to persons or property occurring as a result of tampering, structural or functional modifications, unsuitable or incorrect installations, environments not in keeping with the equipment's protection degree or with the required temperature and humidity conditions, failure to carry out maintenance and periodical inspections and poor repair work.

GENERAL SAFETY INFORMATION

Your attention is drawn to the following actions that could compromise the characteristics of the product:

- Read and retain the instructions which follow.
- Follow all indications and instructions given on the device.
- Make sure that the surface on which the device rests is stable. If it is not, the device could fall, seriously damaging it.
- Make sure that the device rests on a hard (non-padded) surface and that there is sufficient ventilation.
- Do not fix indissolubly the device or its accessories such as power supplies unless specifically provided in this manual.
- When positioning the device, make sure cables do not get damaged.
- [Only OEM equipment] The equipment must be installed in a kiosk or system that provides mechanical, electrical and fire protection.
- The mains power supply must comply with the rules in force in the Country where you intend to install the equipment.
- Make sure that there is an easily-accessible outlet with a capacity of no less than 10A closely to where the device is to be installed.
- Make sure the power cable provided with the appliance, or that you intend to use is suitable with the wall socket available in the system.
- Make sure the electrical system that supplies power to the device is equipped with a ground wire and is protected by a differential switch.
- Before any type of work is done on the machine, disconnect the power supply.
- Use the type of electrical power supply indicated on the device label.
- These devices are intended to be powered by a separately certified power module having an SELV, non-energy hazardous output. (IEC60950-1 second edition).
- [Only POS equipment] The energy to the equipment must be provided by power supply approved by CUSTOM S.p.A.
- Take care the operating temperature range of equipment and its ancillary components.
- Do not block the ventilation openings.
- Do not insert objects inside the device as this could cause short-circuiting or damage components that could jeopardize printer functioning.
- Do not carry out repairs on the device yourself, except for the normal maintenance operations given in the user manual.
- The equipment must be accessible on these components only to trained, authorized personnel.
- Periodically perform scheduled maintenance on the device to avoid dirt build-up that could compromise the correct, safe operation of the unit.
- Do not touch the head heating line with bare hands or metal objects. Do not perform any operation inside the printer immediately after printing because the head and motor tend to become very hot.
- Use consumables approved by CUSTOM S.p.A.



THE CE MARK AFFIXED TO THE PRODUCT CERTIFY THAT THE PRODUCT SATISFIES THE BASIC SAFETY REQUIREMENTS.

The device is in conformity with the essential Electromagnetic Compatibility and Electric Safety requirements laid down in Directives 2006/95/CE and 2004/108/CE inasmuch as it was designed in conformity with the provisions laid down in the following Standards:

- EN 55022 Class B (*Limits and methods of measurements of radio disturbance characteristics of Information Technology Equipment*)
- EN 55024 (*Information Technology Equipment – Immunity characteristics – Limits and methods of measurement*)
- EN 60950-1 (*Safety of information equipment including electrical business equipment*)

The device is in conformity with the essential requirements laid down in Directives 1999/05/CE about devices equipped with intentional radiators. The Declaration of Conformity and other available certifications can be request to support@custom.it please providing the correct part number shown on product label or in the invoice.



GUIDELINES FOR THE DISPOSAL OF THE PRODUCT

The crossed-out rubbish bin logo means that used electrical and electronic products shall NOT be mixed with unsorted municipal waste. For more detailed information about recycling of this product, refer to the instructions of your country for the disposal of these products.

- Do not dispose of this equipment as miscellaneous solid municipal waste, but arrange to have it collected separately.
- The re-use or correct recycling of the electronic and electrical equipment (EEE) is important in order to protect the environment and the wellbeing of humans.
- In accordance with European Directive WEEE 2002/96/EC, special collection points are available to which to deliver waste electrical and electronic equipment and the equipment can also be handed over to a distributor at the moment of purchasing a new equivalent type.
- The public administration and producers of electrical and electronic equipment are involved in facilitating the processes of the re-use and recovery of waste electrical and electronic equipment through the organisation of collection activities and the use of appropriate planning arrangements.
- Unauthorised disposal of waste electrical and electronic equipment is punishable by law with the appropriate penalties.



The format used for this manual improves use of natural resources reducing the quantity of necessary paper to print this copy.

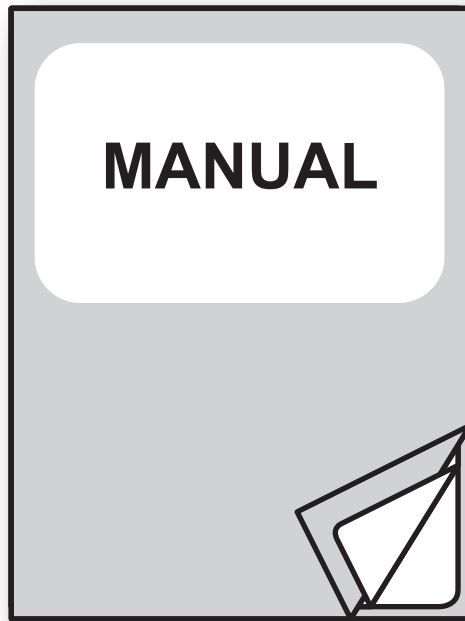

For details on the commands,
refer to the manual with code **77200000030800**

TABLE OF CONTENTS

1	INTRODUCTION	9
1.1	Document structure	9
1.2	Explanatory notes used in this manual	9
2	DESCRIPTION	11
2.1	Box contents	11
2.2	Device components	13
2.3	Product label	14
2.4	Key functions: power up	15
2.5	Key functions: standby	16
2.6	Status messages	17
3	INSTALLATION	19
3.1	Connections	19
3.2	Pairing with Bluetooth® devices	20
3.3	Pinout	27
3.4	Driver and SDK	28
4	OPERATION	29
4.1	Opening cover	29
4.2	Opening connectors compartment	30
4.3	Switch the device ON/OFF	31
4.4	Recharge with power supply	32
4.5	Recharge with docking station (optional)	33
4.6	Loading the paper roll	34
4.7	Low-power mode (only Bluetooth® mode)	35
5	CONFIGURATION	37
5.1	Configuration mode	37
5.2	Setup report	38
5.3	Device status	39
5.4	Printer parameters	40
5.5	Hexadecimal dump	42

6	MAINTENANCE	43
6.1	Paper jam	43
6.2	Planning of cleaning operations	45
6.3	Cleaning	46
6.4	Upgrade firmware	49
7	SPECIFICATION	51
7.1	Hardware specifications	51
7.2	Character specifications	55
7.3	Device dimensions	56
7.4	Power supply dimensions cod. 963GE020000301	57
7.5	Paper specification	58
7.6	Western characters	61
8	CONSUMABLES	69
9	ACCESSORIES	71
10	ALIGNMENT	73
10.1	Enable alignment	74
10.2	Alignment parameters	76
10.3	Printing area	79
11	TROUBLESHOOTING GUIDE	81
12	TECHNICAL SERVICE	83

1 INTRODUCTION

1.1 Document structure

This document includes the following chapters:

1	INTRODUCTION	information about this document
2	DESCRIPTION	general description of device
3	INSTALLATION	information required for a correct installation of the device
4	OPERATION	information required to make the device operative
5	CONFIGURATION	description of the configuration parameters of the device
6	MAINTENANCE	information for a correct periodic maintenance
7	SPECIFICATION	technical specification for the device and its accessories
8	CONSUMABLES	description and installation of the available consumables for the device
9	ACCESSORIES	description and installation of the available accessories for the device
10	ALIGNMENT	information required for managing the paper alignment
11	TROUBLESHOOTING GUIDE	information required for troubleshooting device
12	TECHNICAL SERVICE	information required for contacting the technical service

1.2 Explanatory notes used in this manual

NOTE:

Gives important information or suggestions relative to the use of the device

ATTENTION:

Gives information that must be carefully followed to guard against damaging the device

DANGER:

Gives information that must be carefully followed to guard against operator injury or damage

2 DESCRIPTION

2.1 Box contents

Remove the device from its carton being careful not to damage the packing material so that it may be re-used if the device is to be transported in the future.

Make sure that all the components illustrated below are present and that there are no signs of damage. If there are, contact Customer Service.

MY3-A model

1. Device
2. AC adapter
3. Short Guide
4. Paper roll

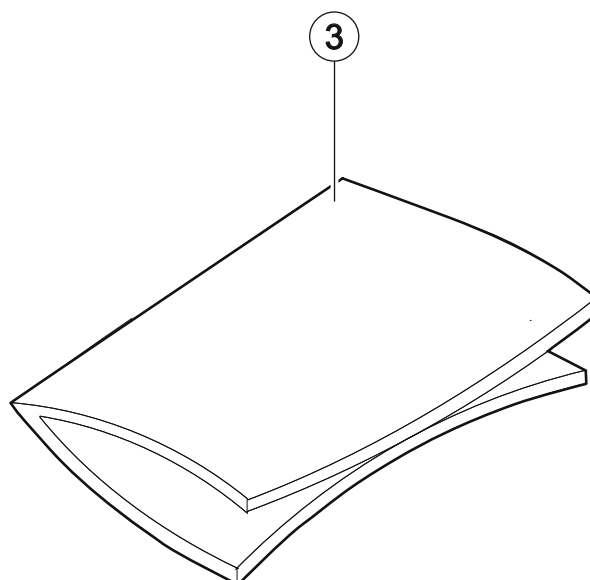
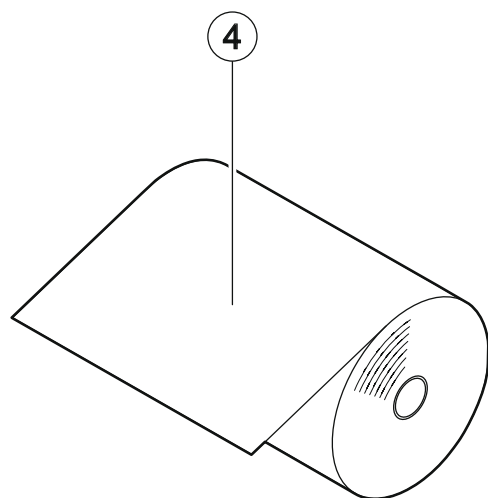
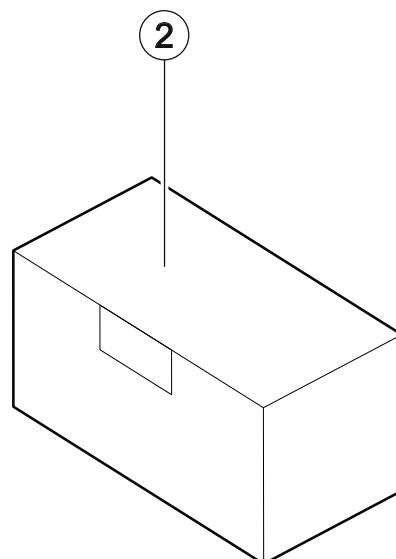
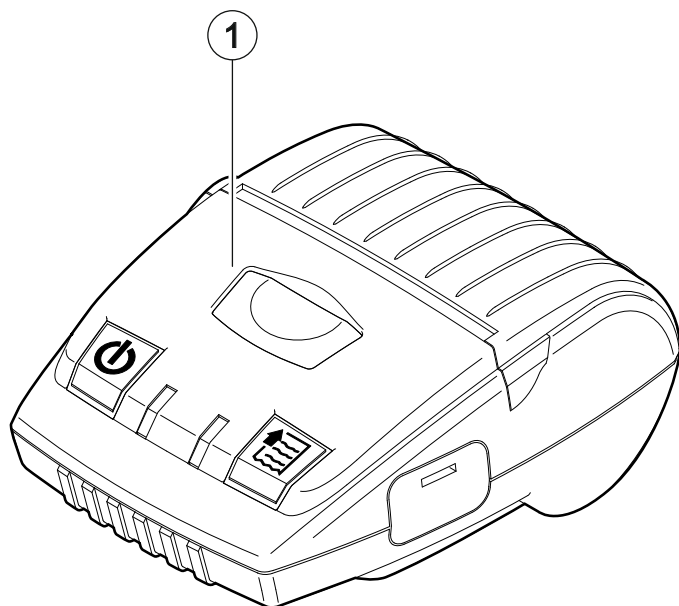

MY3 model

1. Device
2. Shoulder bag
3. Short guide
4. Belt clip (already assembled)

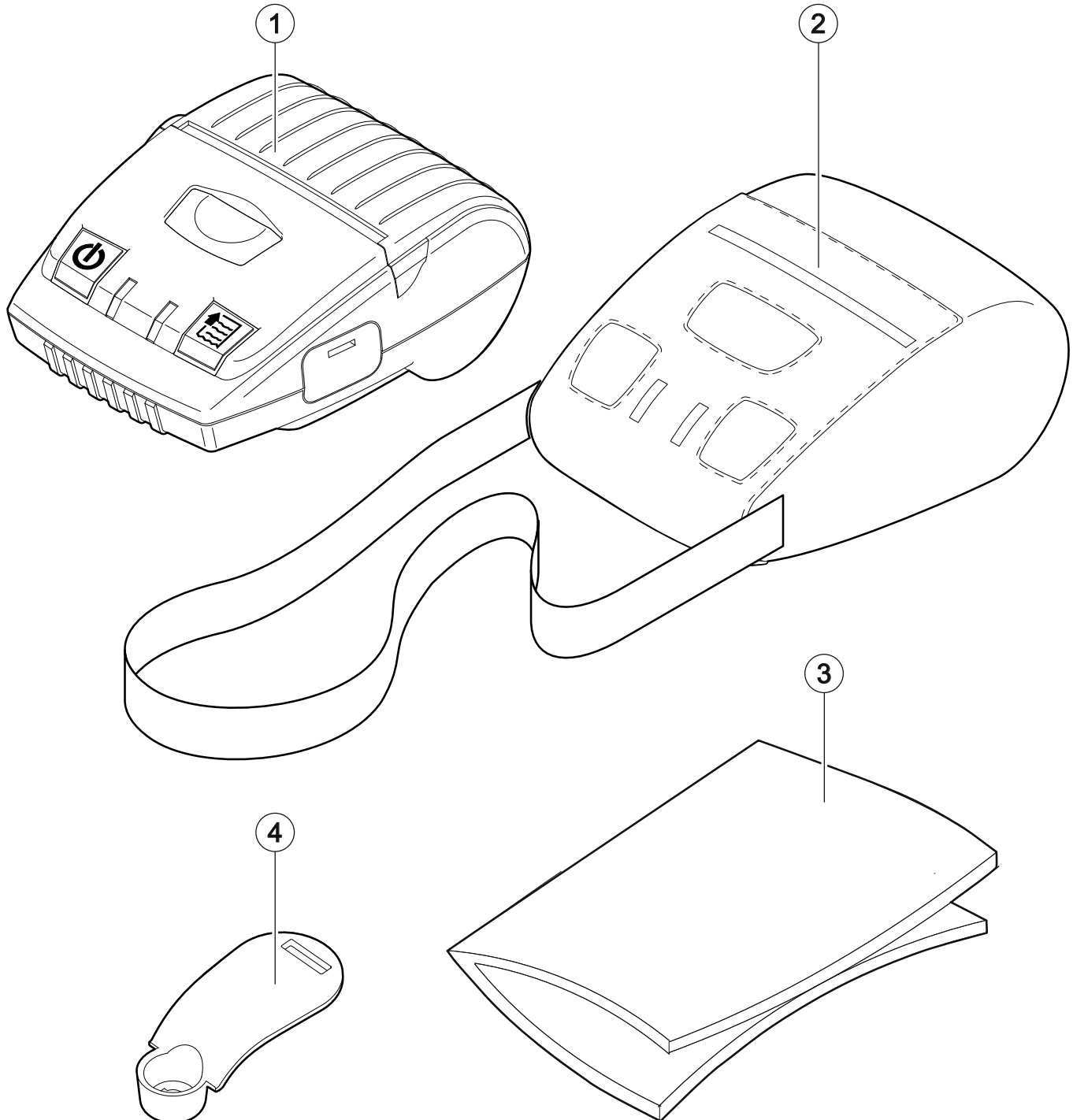

- Open the device packaging.
- Take out the device.
- Remove the packing frame content and remove the packing frame.
- Keep the box, trays and packing materials in the event the device must be transported/shipped in the future.

2.2 Device components

1. Paper compartment cover
2. Paper out
3. Opening key
4. ON/OFF key
5. Status LED
6. Recharge LED
7. FEED key
8. Connectors compartment
9. Battery compartment
10. Contacts for docking station
11. Seat for clip belt

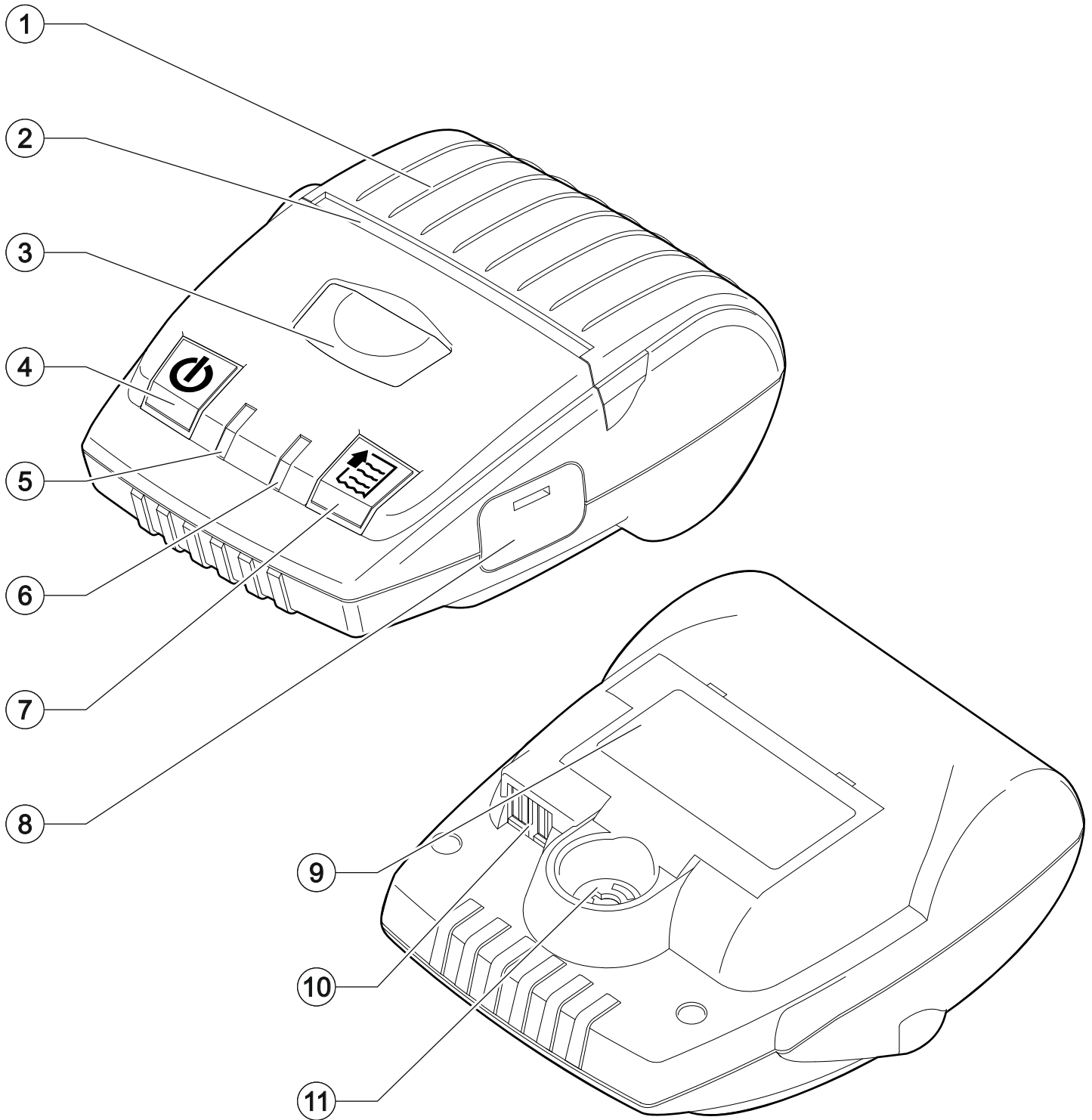

2.3 Product label

PC = Product code (14 digits)
SN = Serial number
HW = Hardware release

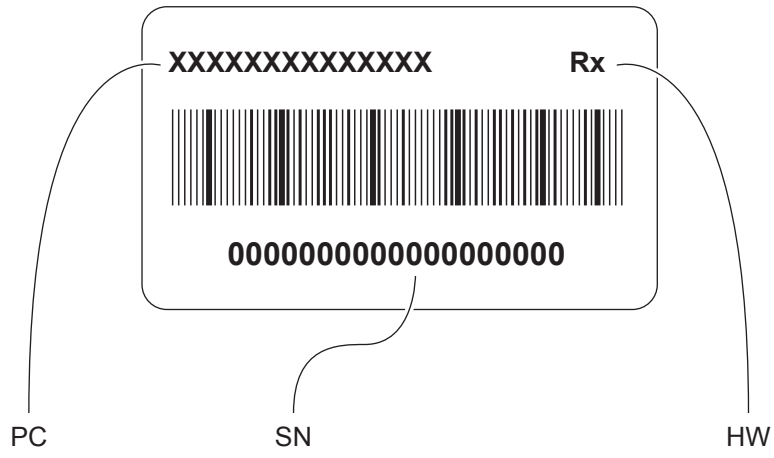

2.4 Key functions: power up

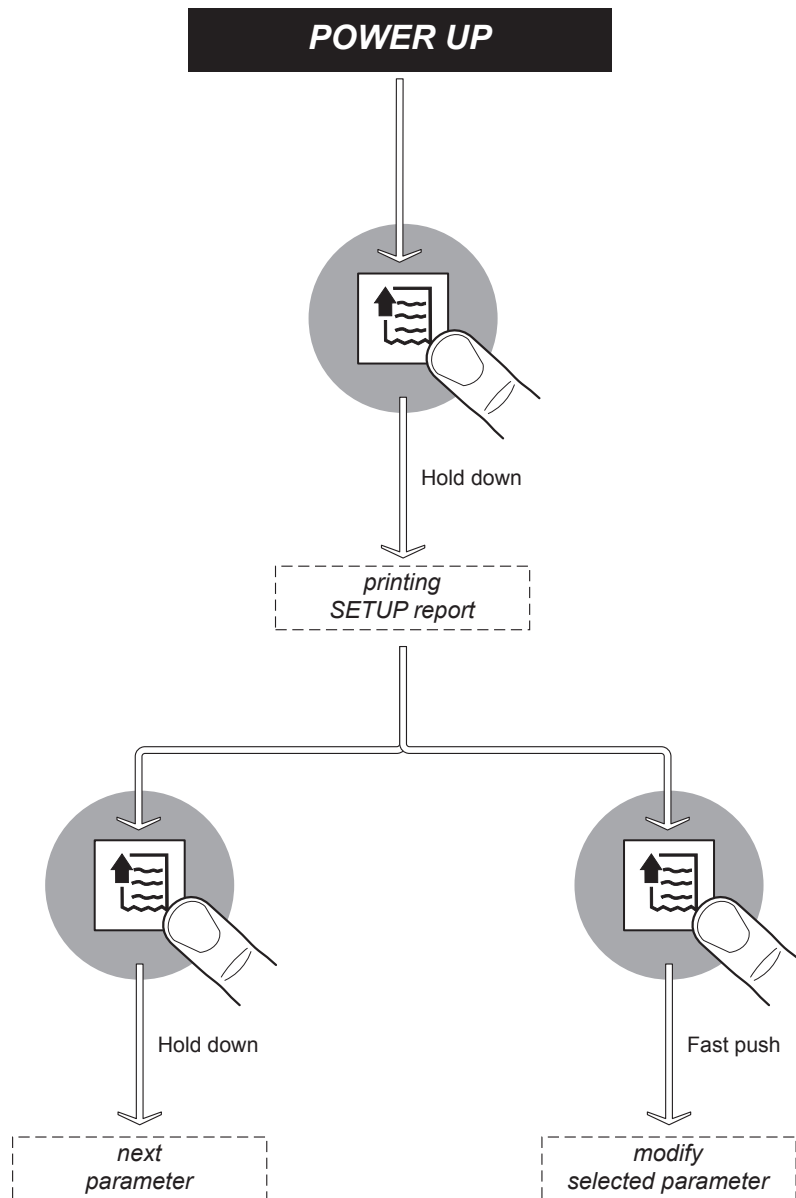



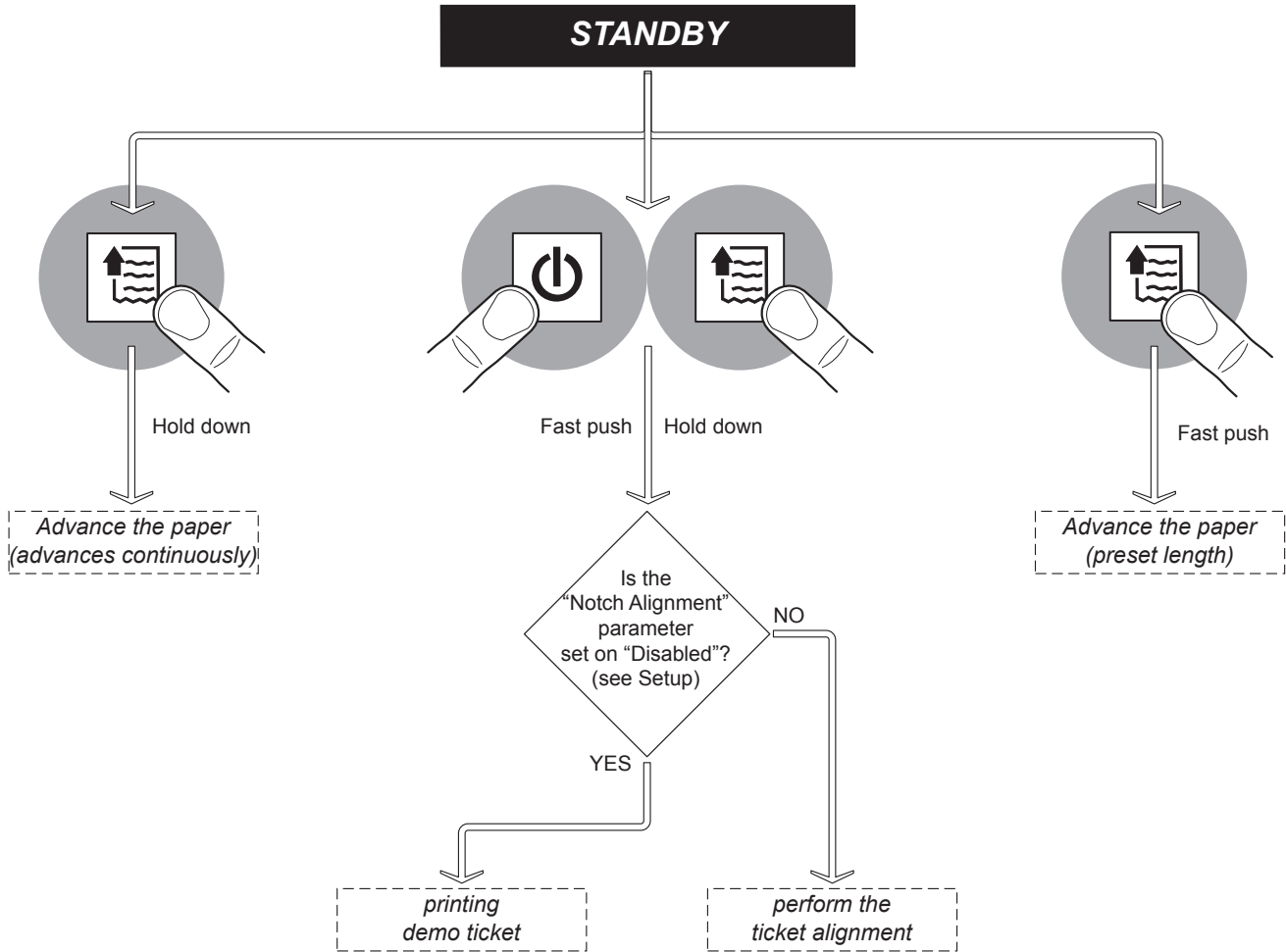

2.5 Key functions: standby



2.6 Status messages



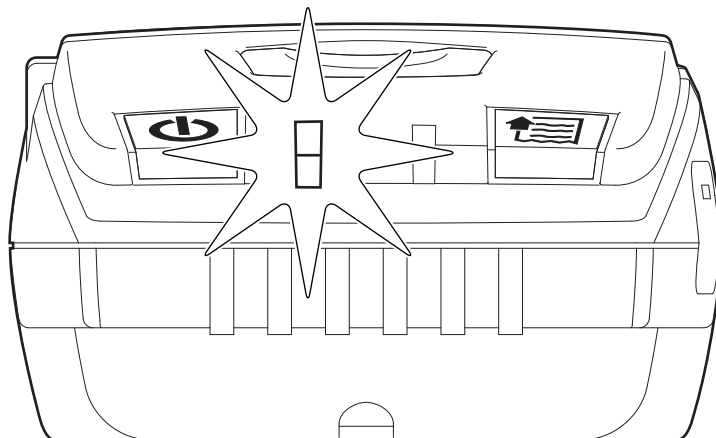

The status LED indicates hardware status of device. Given in the table below are the various led signals and the corresponding device status.

Status LED flashes

STATUS LED		DESCRIPTION	
-		OFF	DEVICE OFF
BLUE NOTIFICATION STATUS		x1	(Bluetooth®) DEVICE ON: STANDBY
GREEN NOTIFICATION STATUS		x1	(USB) DEVICE ON: STANDBY (Bluetooth®) LOW-POWER MODE
YELLOW NOTIFICATION STATUS		x2	PRINT HEAD OVERHEATED
		x3	PAPER END
		x4	LOW BATTERY LEVEL
GREEN RECOVERABLE ERROR		x2	RECEPTION ERRORS (parity, frame error, overrun error)
		x3	COMMAND NOT RECOGNIZED
		x4	COMMAND RECEPTION TIME OUT



Recharge LED status

STATUS LED			DESCRIPTION
-		OFF	BATTERY OK
RED UNRECOVERABLE ERROR		x1	BATTERY FAULT
RED BATTERY IN CHARGE		-	RECHARGE
GREEN BATTERY IN CHARGE		-	RECHARGE COMPLETE

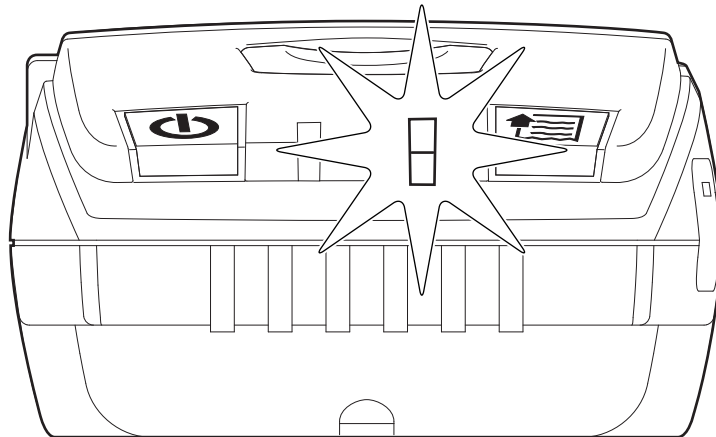

3 INSTALLATION

3.1 Connections

The following figure shows the possible connections for the device.

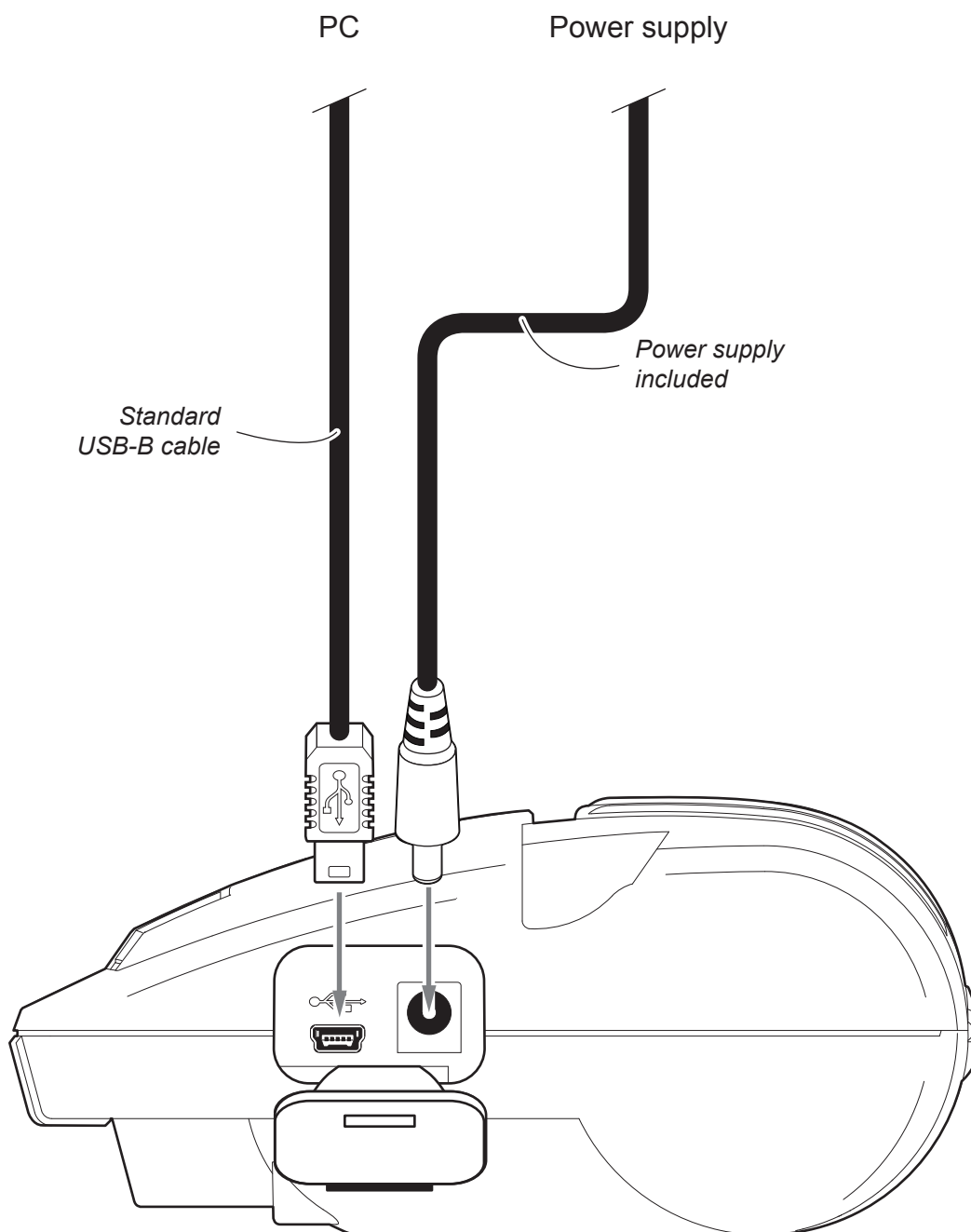

ATTENTION: In some conditions, we recommend the installation of a ferrite core on the power supply cable.

3.2 Pairing with Bluetooth® devices

The Bluetooth® connectivity of MY3 allows the wireless printing from a PC (eg. using a text editor or third-part software, from a mobile device Android Apple® and Windows or Phone (only for MY3-A).

To perform the wireless printing with a device (host) equipped with Bluetooth® connectivity is needed to pair with MY3.

NOTE: The screen images used in this paragraph may be different from the screens that appear on the device used for printing and may vary depending on the version of the operating system PC, Android, Windows Phone and iOS®.

PC connection

Make sure that the “Interface” parameter of the printer is set to Bluetooth® (see par. 5.4) and the printer is ON.

To pair with MY3 from an PC device, follow the instructions below:

1



Execute from the PC the search for Bluetooth® devices available.

2



If MY3 is in the range of your PC, it is identified as a Bluetooth® device MY3_<BT address>.

3

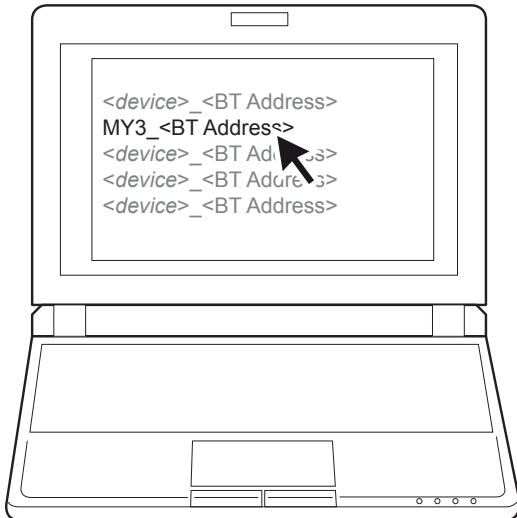

Select from PC the Bluetooth® device MY3_<BT address> to set the pairing.
Enter the PIN for MY3 (1234).
Now you can print wireless from a PC on MY3.

NOTE: Once the pairing between host and MY3 was made, no longer need to run it again even if communication is interrupted (power off, stand by, etc.).

Connecting to an Android device

Make sure that the “Interface” parameter of the printer is set to Bluetooth® (see par. 5.4) and the printer is on.

To pair with MY3 from an Android device, follow the instructions below:

1

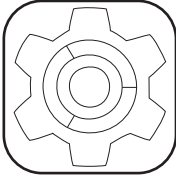

Tap the settings icon to open the menu.

2



Tap the Bluetooth® icon to open the menu.

3

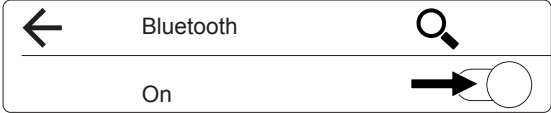

Enable the Bluetooth® to detect the device.

4

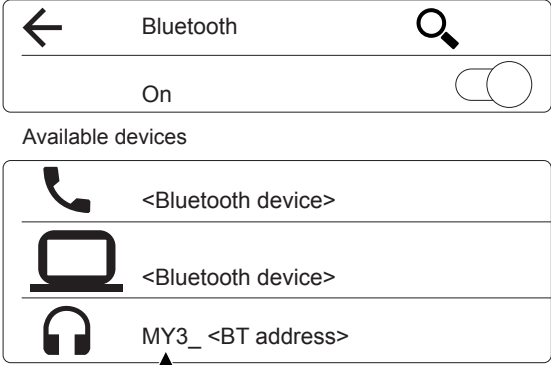

Select the device named “MY3_<BT address>”.

5A "Pairing BT" = Disabled

Bluetooth pairing request

Device "MY3_<BT address>"
Pairing code "<random number>"

Confirm pairing operation.

Cancel	Pair
--------	-------------



If "Pairing BT" parameter of the device is set to Disabled (see par. 5.4) confirm the pairing with "MY3_<BT address>".

5B "Pairing BT" = Enabled

Bluetooth pairing request

Device "MY3_<BT address>"

PIN contains letters or symbols
 Type this PIN on the other device.

Cancel	Pair
--------	-------------



If "Pairing BT" parameter of the device is set to Disabled (see par. 5.4) confirm the pairing with "MY3_<BT address>".

6

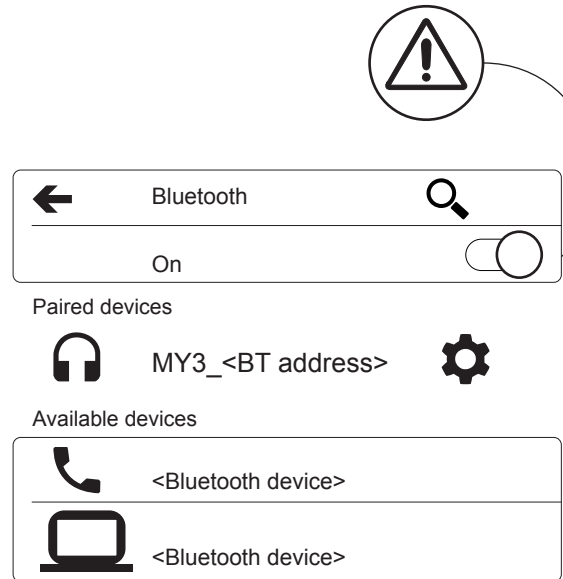

Once pairing is completed, do not turn off Bluetooth® communication. Otherwise, communication will be interrupted.

NOTE:

To demonstrate printing on an Android device install the APP "CustomPrint" available in the download area of the web site www.custom.biz.

Connecting to a Widows Phone

Make sure that the “Interface” parameter of the printer is set to Bluetooth® (see par. 5.4) and the printer is on.

To pair with MY3 from a Windows Phone device, follow the instructions below:

1

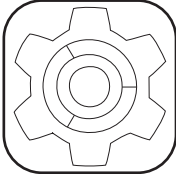

Tap the settings icon to open the menu.

2



Tap the Bluetooth® icon to open the menu.

3

Bluetooth
Status
On



Devices

<Bluetooth device>	Not Paired
<Bluetooth device>	Not Paired

Enable the Bluetooth® to detect the device.

4

Bluetooth
Status
On

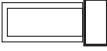

Devices

<Bluetooth device>	Not Paired
<Bluetooth device>	Not Paired
MY3_ <BT address>	Not Paired



Select the device named “MY3_<BT address>”.

5A "Pairing BT" = Disabled

Pairing accessory

Make sure that this PIN "random number" matches the PIN that is displayed on "MY3_ <BT address>".

ok	cancel
-----------	--------



If "Pairing BT" parameter of the device is set to Disabled (see par. 5.4) confirm the pairing with "MY3_ <BT address>".

5B "Pairing BT" = Enabled

Pairing MY3_<BT address>

Enter your PIN to connect.

done	cancel
-------------	--------



If "Pairing BT" parameter of the device is set to Enabled (see par. 5.4) enter the PIN '1234' to pair with "MY3_<BT address>".

6



Bluetooth
Status
On

Devices

MY3_<BT address>	Paired
<Bluetooth device>	Not paired
<Bluetooth device>	Not paired

Once pairing is completed, do not turn off Bluetooth® communication. Otherwise, communication will be interrupted.

NOTTo demonstrate printing on a Windows phone device install the APP "CustomPrint" available in the download area of the web site www.custom.biz.

Connecting to an iOS® device (only for MY3-A)

Make sure that the “Interface” parameter of the printer is set to Bluetooth® and the “Apple Interface” parameter is set to “Enabled” (see par. 5.4) and the printer is on.

To pair with MY3 from an Apple® device, follow the instructions below:

1

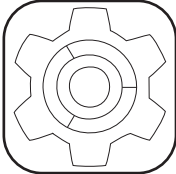

Tap the settings icon to open the menu.

2



Tap the Bluetooth® icon to open the menu.

3



Bluetooth

DEVICES

<Bluetooth device>	Not Paired
<Bluetooth device>	Not Paired

Enable the Bluetooth® to detect the device.

4



Bluetooth

DEVICES

<Bluetooth device>	Not Paired
<Bluetooth device>	Not Paired
MY3A_ <BT address>	Not Paired



Select the device named “MY3A_<BT address>”.

5

Bluetooth Pairing Request

“MY3A_<BT address>” would like to pair with your <device>. Confirm that the code “ random number” is shown on “MY3A_<BT address>”.

Cancel

Pair



Confirm the pairing with “MY3A_<BT address>”.

6



Bluetooth



DEVICES

MY3A_<BT address>	Connected
<Bluetooth device>	Not Paired
<Bluetooth device>	Not Paired

Once pairing is completed, do not turn off Bluetooth® communication. Otherwise, communication will be interrupted.

NOTE:

To demonstrate printing on an Apple® device install the APP “CustomPrint” available in the download area of the web site www.custom.biz.

3.3 Pinout

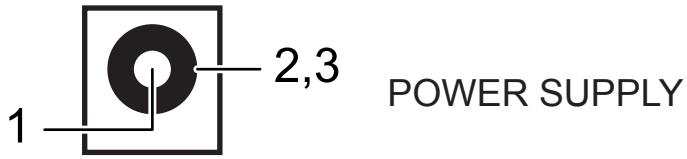

J6	1	+24 Vdc
	2	GND
	3	GND

ATTENTION: Respect power supply polarity.



MINI USB INTERFACE
MINI USB connector type B female

J1	1	USB-VBUS (out)
	2	USB-D-
	3	USB-D+
	4	n.c.
	5	GND

3.4 Driver and SDK

The drivers are available for the following operating system:

OPERATING SYSTEM	DESCRIPTION	INSTALLATION PROCEDURE
Windows	Driver for Windows XP	From the START menu, press Run and type-in the path where the SW was saved on your PC, then click OK. Follow the instructions that appear on the screen to install the driver.
	Driver for Windows VISTA (32/64bit)	
	Driver for Windows 7 (32/64bit)	
	Driver for Windows 8 (32/64bit)	
	Driver for Windows 8.1 (32/64bit)	
	Driver for OPOS	
Linux	(32/64bit)	Follow the instruction get back on the README.TXT file. You can find it in the software package downloaded in advance.
Android	SDK for CustomAndroidAPI	Extract the zipped folder to the destination path desired. Follow the instructions present in the software package that you downloaded on how to install and use the library.
iOS (only MY3-A)	SDK for CustomiOSApi	Extract the zipped folder to the destination path desired. Follow the instructions present in the software package that you downloaded on how to install and use the library.

NOTE:

All drivers can be found in the **DOWNLOAD** section of the web site www.custom.biz.

4 OPERATION

4.1 Opening cover

1

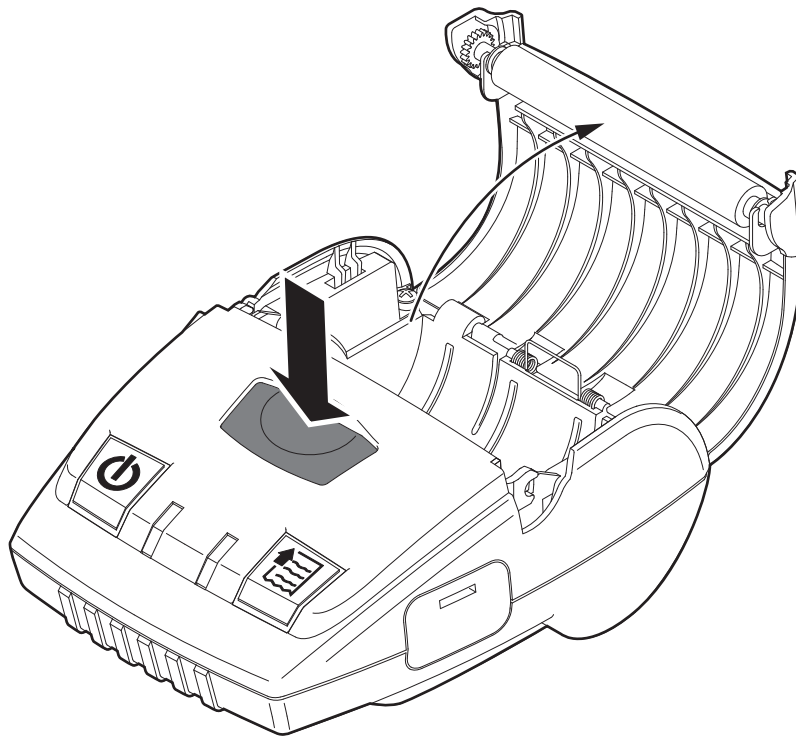

Press opening key
to lift the cover.

2

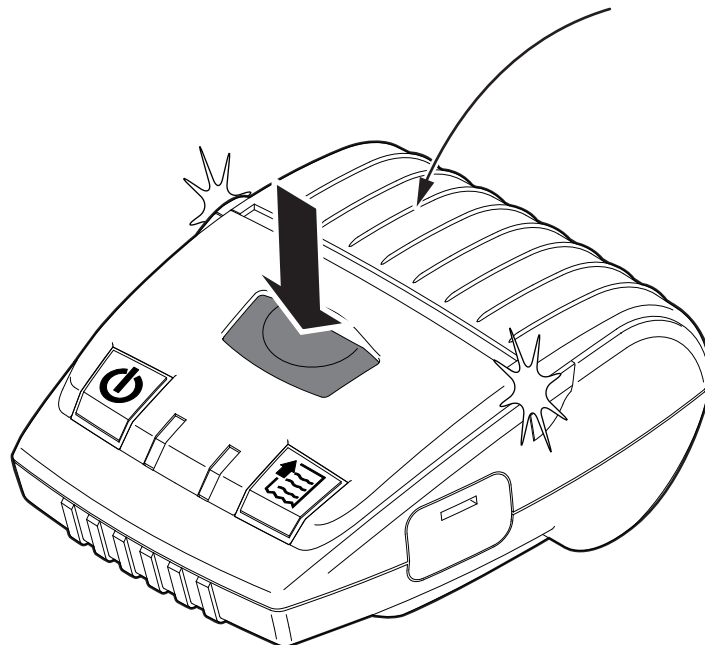

Press opening key
and close the cover of the device.

ATTENTION:
Closing the cover without pressing the opening key can damage the cover.

4.2 Opening connectors compartment

1

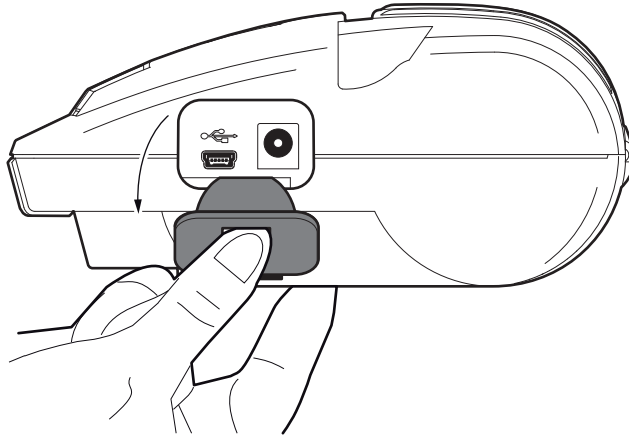

Access the connectors compartment by removing the rubber plug.

2

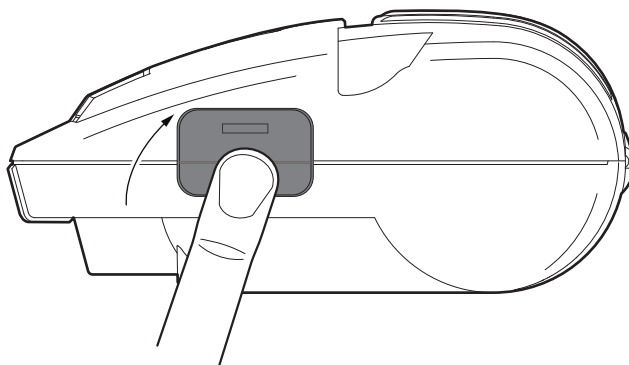

If the connectors are not used, protect the compartment by inserting the rubber plug with light pressure.

4.3 Switch the device ON/OFF

1

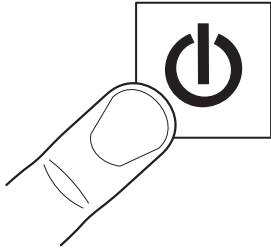

Turn on the device by holding down the ON/OFF key.

2

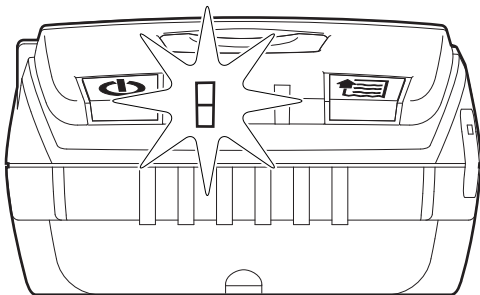

The status LED turn on and the device is ready.

3

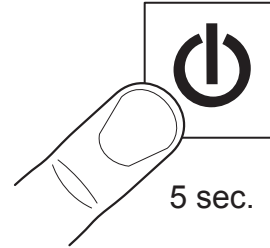

Turn off the device by holding down the ON/OFF key.

4

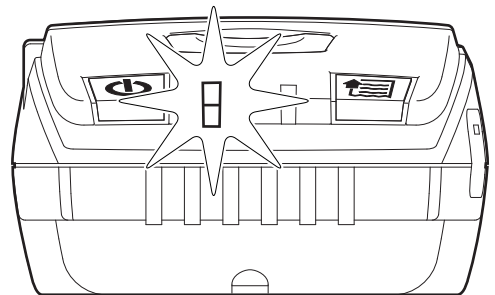

The status LED (red) indicates that the device is powering down.

4.4 Recharge with power supply

1

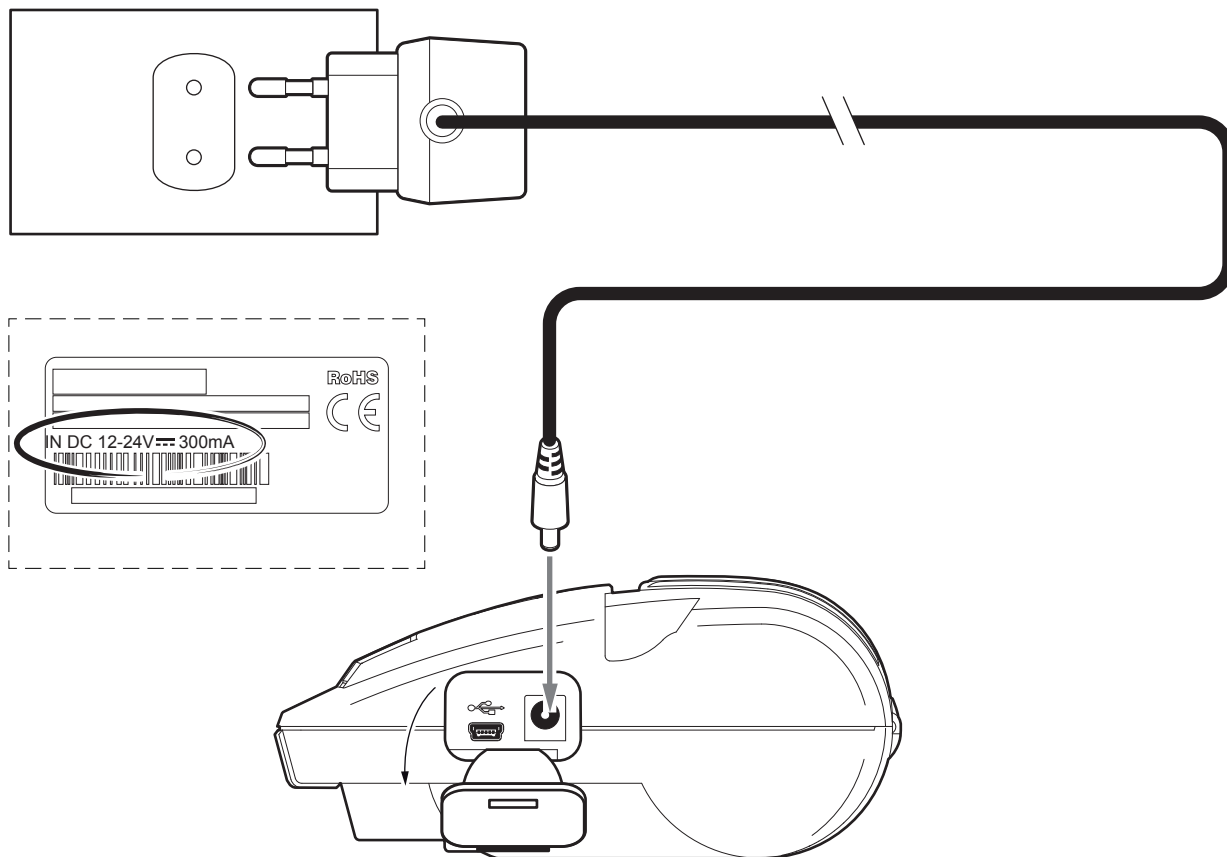

Open the connectors compartment (see paragraph 4.2).
Connect the power adapter (supplied) to the device and to the mains outlet.
Use the type of electrical power supply indicated on the label.

2

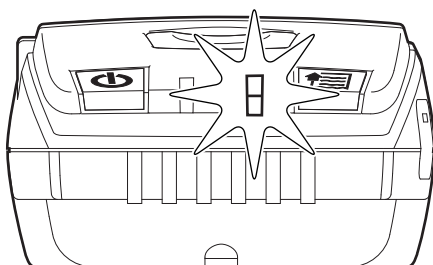

The indicator lights (red) switch ON,
the device is charging.

4.5 Recharge with docking station (optional)

1

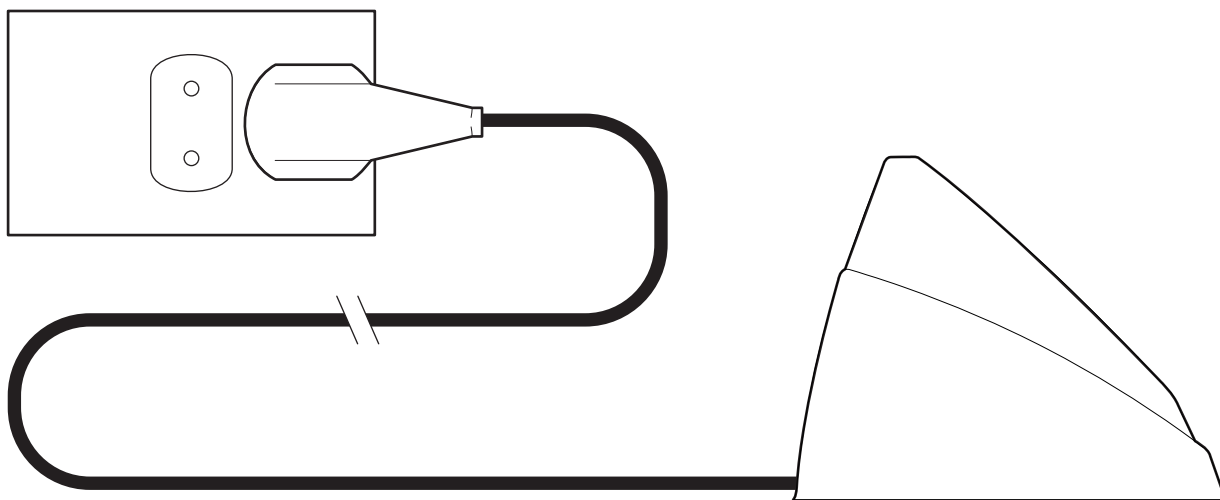

Connect the docking station the mains outlet.
Use the type of electrical power supply indicated on the label.

2

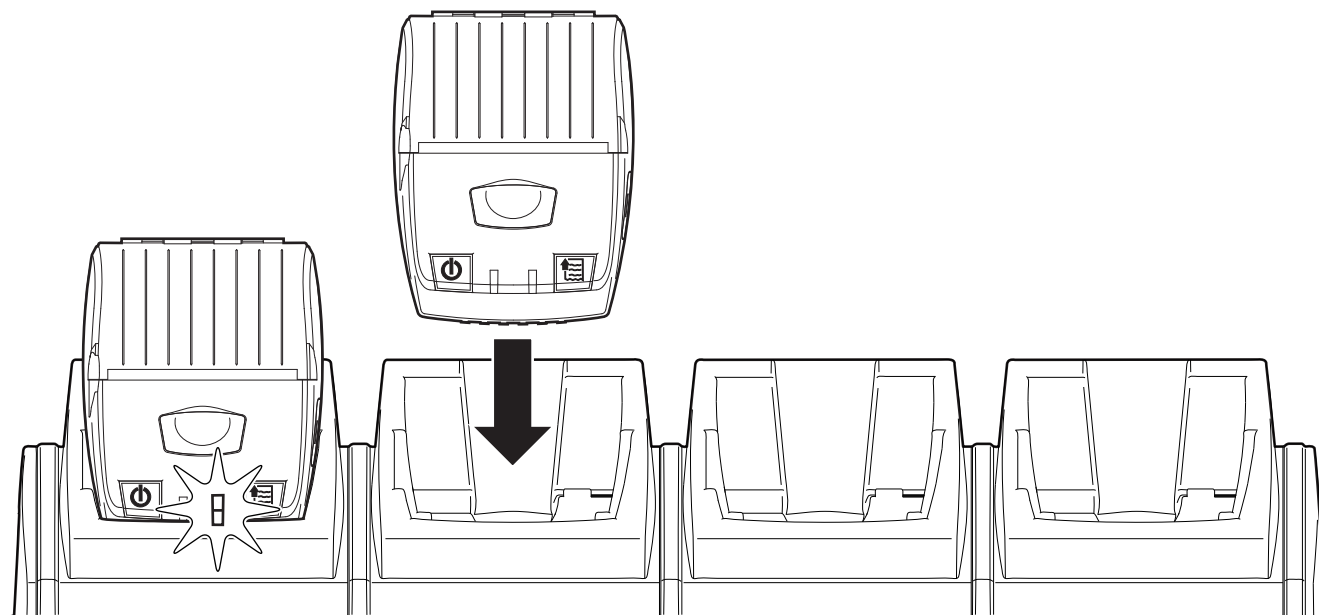

Inserting the device in the docking station.
The indicator lights (red) switch ON, the device is charging.

NOTE:

If you are using the shoulder strap, remove it before inserting the printer in the docking station

4.6 Loading the paper roll

To change the paper proceed as follows. At every change of paper, check inside the device to locate and remove any scraps of paper.

1

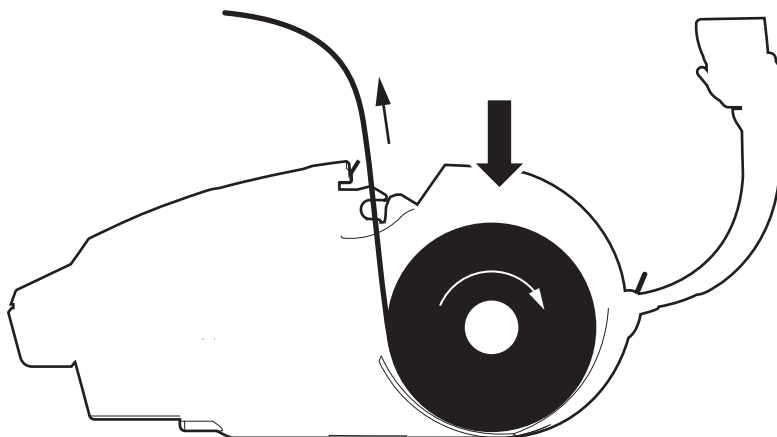

Open the cover of the device (see paragraph 4.1).
Place the roll in the paper compartment and pull out the paper for a few centimetres.

2

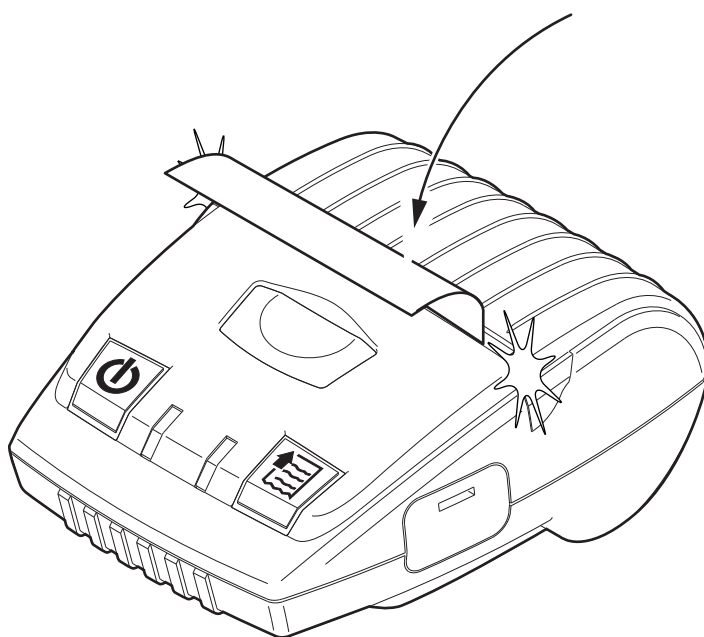

Close the cover of the device
(see paragraph 4.1).

4.7 Low-power mode (only Bluetooth® mode)

The low-power mode allows the device to save energy and increase the battery life when operating in Bluetooth®. The low-power mode is automatically enabled after 5 minutes of device inactivity. To terminate the low-power mode and return to operative mode press the FEED or ON / OFF key.

The device automatically returns to operative mode when it receives a print command.

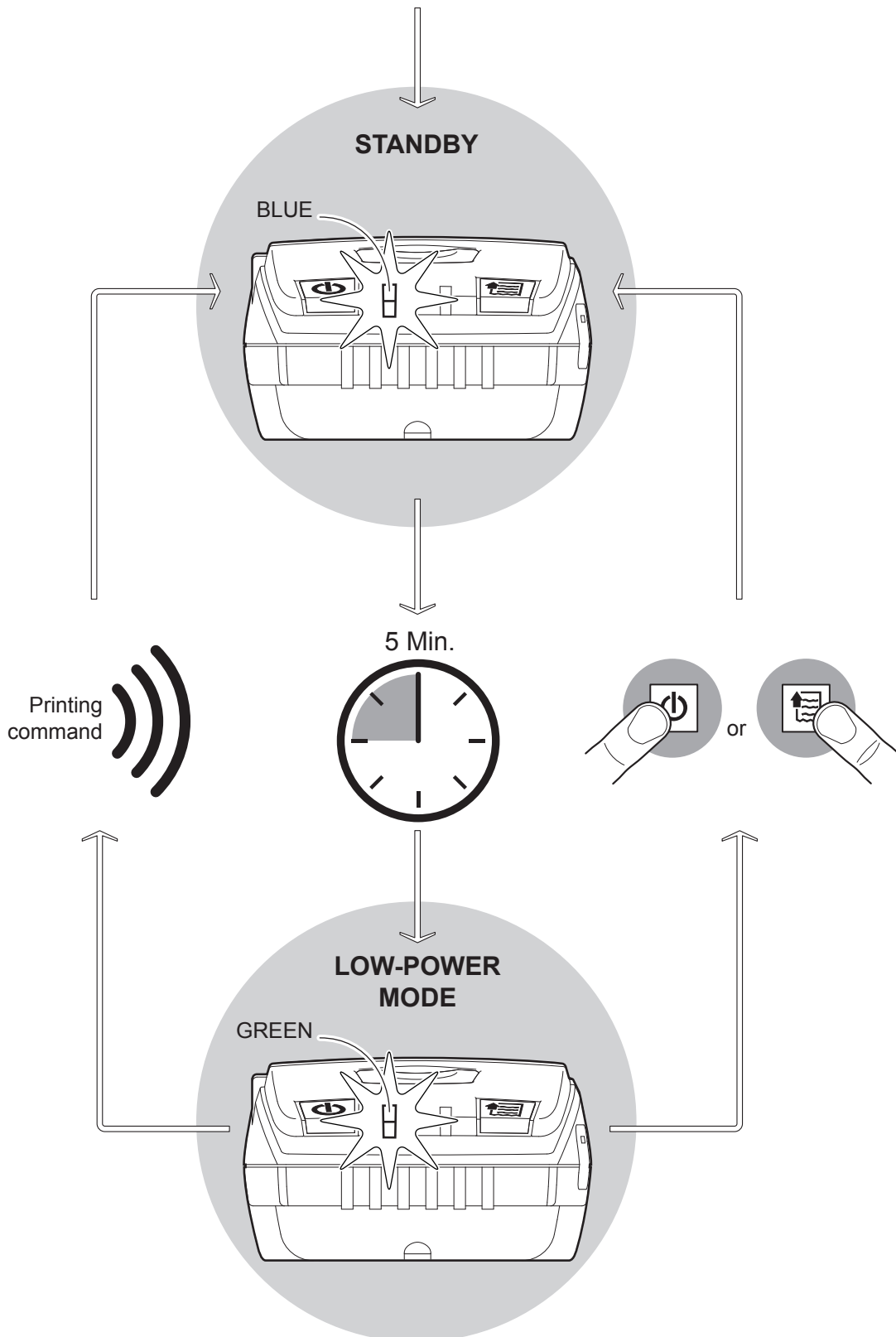

5 CONFIGURATION

5.1 Configuration mode

To enter the configuration mode and print a SETUP report with the operating parameters of the device, proceed as follows.

1

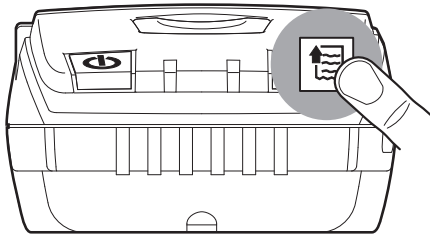

Press the FEED key.

2

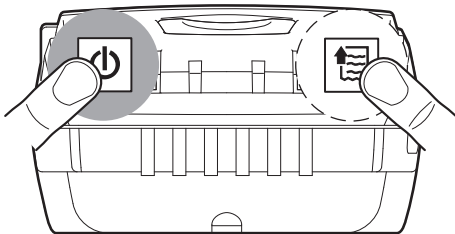

While pressing the FEED key, switch on the device by pressing the ON/OFF key.

3

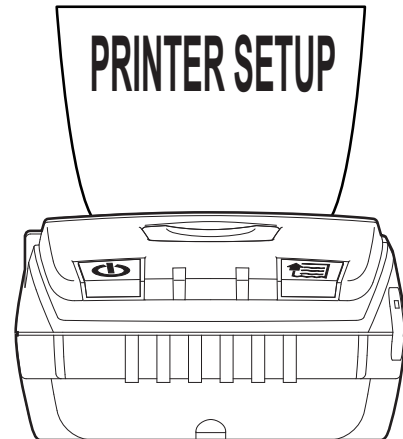

The device prints the report with the settings parameters. Follow the instruction printed on paper to proceed with configuration procedure.

5.2 Setup report

The following figures show the setup reports of the device. The shown values for parameters are sample values; for the list and the description of device parameters see the following paragraphs.

*DEVICE NAME and
FIRMWARE MODULE
RELEASE*

< device name >	-	rel.1.00
BOOT LOADER	-	rel. 1.00

*DEVICE
STATUS*

PRINTER SETUP

PRINTER TYPE = <device name>
 HEAD VOLTAGE [V] = 07.64
 HEAD TEMPERATURE [°C] = 20
 PIN BT = 1234
 BT Address = <BT address>
 BT Module Build Rel = <release>

*DEVICE
PARAMETERS*

Interface: **Bluetooth**
 BT Autoreconnect.....: **Disabled**
 USB Address Number: **0**
 Pairing BT.....: **Disabled**
 Autofeed: **CR Disabled**
 Print Mode: **Normal**
 Speed / Quality.....: **High Speed**
 Chars / inch: **A=17 B=22 cpi**
 Columns 22 cpi.....: **60 columns**
 PowerOFF time: **30 min**
 Notch alignment: **Enabled**
 Notch dist. [mm x 10].....: **0**
 Notch dist. [mm x 1].....: **0**
 Notch dist. [mm x .1].....: **0**
 Print Density: **0%**

KEYS FUNCTIONS

[FEED PUSH] *key to enter setup*
[FEED FAST PUSH] *key to skip setup*

5.3 Device status

The device operating status is indicated in the configuration print-out in which, next to the name of the components displayed, the following information is given:

HEAD VOLTAGE	<i>voltage of the head</i>
HEAD TEMPERATURE	<i>temperature of the head</i>
PIN BT*	<i>device password</i>
BT ADDRESS*	<i>device identifier</i>
BT MODULE BUILD REL.*	<i>firmware release of the Bluetooth® module</i>

NOTE:

* : If the parameter is printed only when the “Interface” parameter is set to Bluetooth®

5.4 Printer parameters

This device allows the configuration of the parameters listed in the following table.

The parameters marked with the symbol ^D are the default values.

Settings remain active even after the device has been turned off and they are stored in non-volatile memory.

INTERFACE	<p><i>Interface in use:</i></p> <p>USB Bluetooth^{®D}</p> <p style="text-align: center;">NOTE: When the Bluetooth[®] interface is enabled do not send data on USB line.</p>										
BT AUTORECONNECT	<p><i>Setting the automatically connection function to Apple[®] devices:</i></p> <p>Disabled ^D = <i>To communicate with the printer must perform the pairing between the Apple[®] device and the printer when communication is interrupted (power off, stand by, etc.).</i></p> <p>Enabled = <i>The printer automatically attempts to restore the connection with the last device connected Apple[®] whenever communication is interrupted (power off, stand by, etc.). Before enabling this function, you must perform the pairing between the Apple[®] device and printer.</i></p> <p style="text-align: center;">NOTE: The parameter is printed only for MY3-A models.</p>										
USB ADDRESS NUMBER	<p><i>Numerical address code for the univocal identification of the USB device (in case of more than a USB device connected with the same PC):</i></p> <table style="margin-left: auto; margin-right: auto;"> <tr> <td>0^D</td> <td>2</td> <td>4</td> <td>6</td> <td>8</td> </tr> <tr> <td>1</td> <td>3</td> <td>5</td> <td>7</td> <td>9</td> </tr> </table>	0 ^D	2	4	6	8	1	3	5	7	9
0 ^D	2	4	6	8							
1	3	5	7	9							
PARING BT	<p><i>Setting the paring function for the Bluetooth[®] devices:</i></p> <p>Disabled ^D = <i>pairing function disabled. No passkey is requested to make association</i></p> <p>Enabled = <i>pairing function enabled. To set it entering the pincode/passkey indicated on the setup report "PIN BT" (1234).</i></p> <p style="text-align: center;">NOTE: The parameter is printed only when the "Interface" parameter is set to Bluetooth[®] To communicate with Bluetooth[®] devices Apple[®] set the parameter to Disabled.</p>										
PRINT MODE	<p><i>Printing mode:</i></p> <p>Normal ^D = <i>enables printing in normal direction</i></p> <p>Reverse = <i>enables printing rotated 180 degrees</i></p>										
SPEED / QUALITY	<p><i>Setting of printing speed and printing quality:</i></p> <p>Normal ^D Low</p>										
CHARS / LINE	<p><i>Font selection:</i></p> <p>A = 17 / B = 22 col A = 13 / B = 17 col ^D</p>										

COLUMNS 22 CPI*Select the number of columns:**60 col^D**64 col*

NOTE: The parameter "Columns 22 cpi" is displayed only in case that the parameter "Chars/Inch" is "A=17 B=22cpi".

POWER OFF TIME*Inactivity time of device**None 4 hours**30min^D 6 hours**1 hours 8 hours**2 hours*

NOTCH ALIGNMENT*Alignment management:**Disabled^D = the notch alignment is not performed**Enabled = the notch alignment is performed*

NOTCH DISTANCE*"Notch Distance" is the minimum distance (in mm) between the upper edge of ticket and the notch (see chapter 10).**The numeric value of the distance is made up with the following four parameters for the setting of three digits (two for the integer part of the number, one for the decimal part and of the sign):*

*Setting the digit for tens:***NOTCH DISTANCE [mm x 10]**

<i>0^D</i>	<i>2</i>	<i>4</i>	<i>6</i>	<i>8</i>
<i>1</i>	<i>3</i>	<i>5</i>	<i>7</i>	<i>9</i>

*Setting the digit for units:***NOTCH DISTANCE [mm x 1]**

<i>0^D</i>	<i>2</i>	<i>4</i>	<i>6</i>	<i>8</i>
<i>1</i>	<i>3</i>	<i>5</i>	<i>7</i>	<i>9</i>

*Setting the digit for decimals:***NOTCH DISTANCE [mm x .1]**

<i>0^D</i>	<i>2</i>	<i>4</i>	<i>6</i>	<i>8</i>
<i>1</i>	<i>3</i>	<i>5</i>	<i>7</i>	<i>9</i>

NOTES:

For example, to set the notch distance to 15 mm, modify the parameters as follows:

Notch Distance [mm x 10] = 1

Notch Distance [mm x 1] = 5

Notch Distance [mm x .1] = 0

If the "Notch Alignment" parameter is disabled, the parameters for the "Notch Distance" are not printed.

PRINT DENSITY*Adjusting the printing density:**-50% -12% +25% Label**-37% 0^D +37%**-25% +12% +50%*

5.5 Hexadecimal dump

This function is used for the diagnosis of the characters received from the communications port. Characters are printed as hexadecimal code and the corresponding ASCII code (see below). Each line is preceded by a counter in hexadecimal that indicates the number of bytes received.

During the startup, if you hold down the FEED key, the printer enters the self-test routine and print the setup report. The printer remains in standby until a key is pressed or characters are received through the communication port (Hexadecimal Dump mode). For each character sent, the receipt contain an indication of the hexadecimal and ASCII values (if the characters are underlined, the receive buffer is full). Shown below is an example of a Hexadecimal Dump:

HEXADECIMAL DUMP									
31	32	33	34	35	...	<u>12345</u>	...		
39	30	31	32	33	...	<u>90123</u>	...		
37	38	39	75	69	...	<u>789ui</u>	...		
68	6B	6A	73	64	...	<u>hkjsd</u>	...		
73	64	66	6B	6A	...	<u>sdfkj</u>	...		
66	73	64	66	6B	...	<u>fsdfk</u>	...		
65	69	6F	79	75	...	<u>eioyu</u>	...		
6F	72	69	75	77	...	<u>oriuw</u>	...		
6F	75	77	65	72	...	<u>ouwer</u>	...		
77	65	72	69	6F	...	<u>werio</u>	...		
72	69	6F	75	77	...	<u>riouw</u>	...		
6B	6C	73	64	66	...	<u>kl sdf</u>	...		
64	66	6B	73	64	...	<u>dfksd</u>	...		
73	64	66	6B	6A	...	<u>sdfkj</u>	...		
66	6B	F2	6A	73	...	<u>fk>j</u>	...		
6A	6B	6C	68			<u>jklh</u>			

6 MAINTENANCE

6.1 Paper jam

1

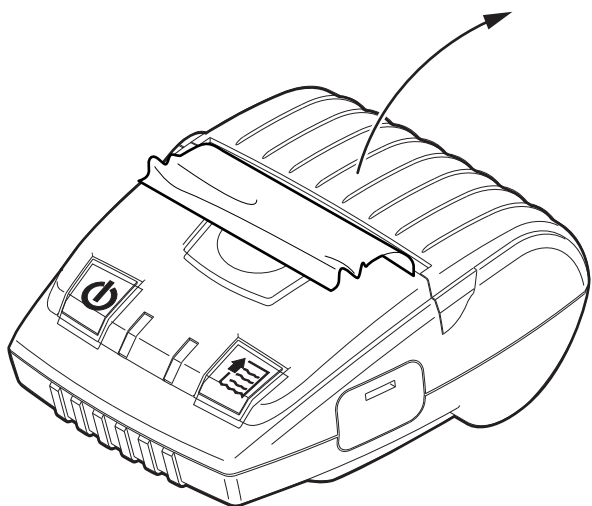

Open the cover of the device
(see paragraph 4.1).

2

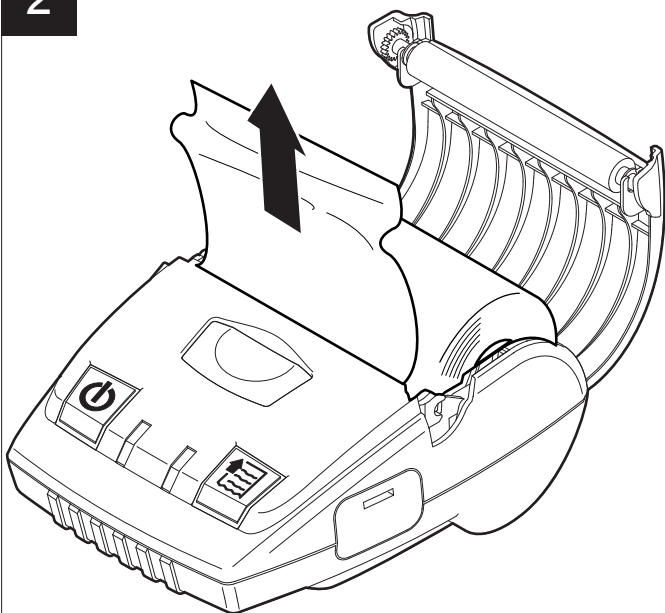

Lift the damaged paper, check and remove possible
scraps of paper.

3

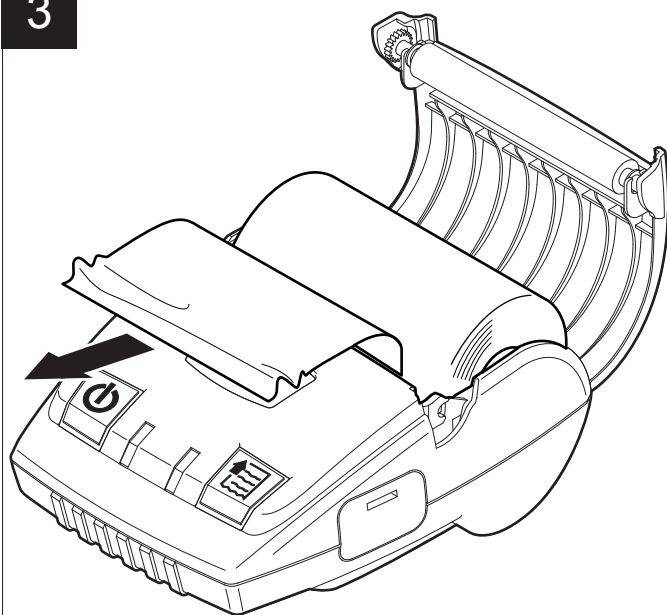

Pull the paper in order to have the damaged part
outside the device.

4

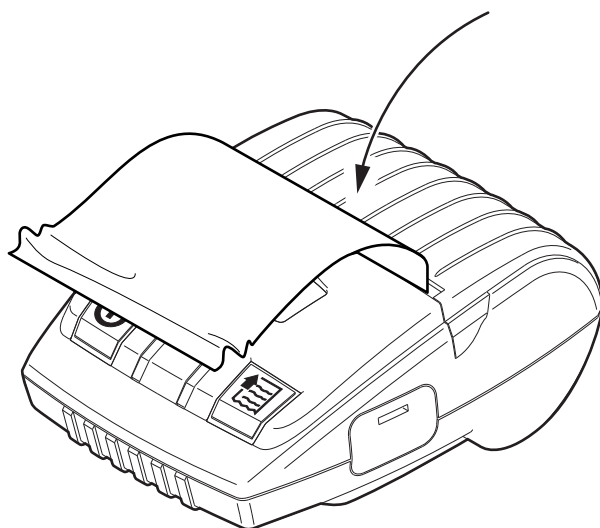

Close the cover of the device
(see paragraph 4.1).

5

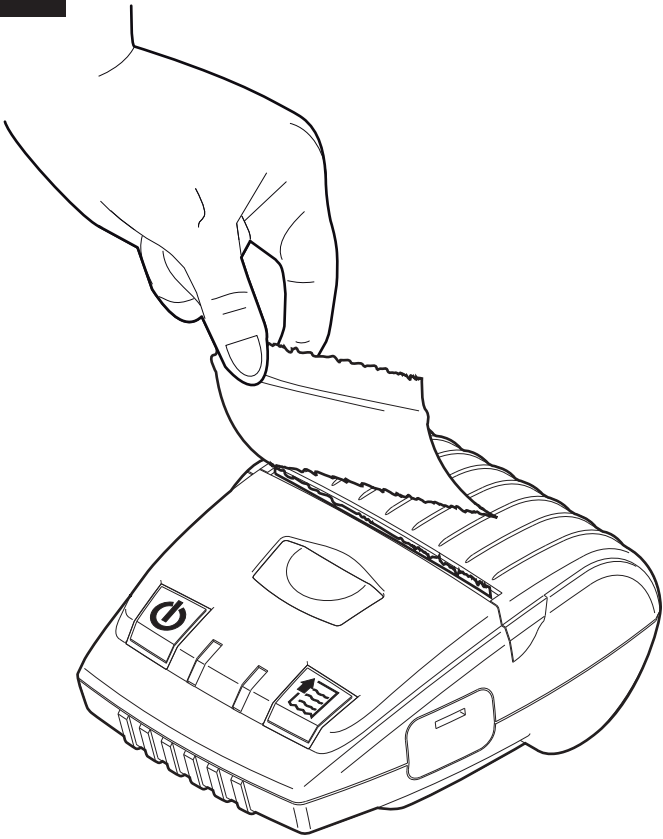

Tear off the excess paper.

6.2 Planning of cleaning operations

The regular cleaning of the device keeps the print quality and extends its life. The following table shows the recommended planning for the cleaning operations.

EVERY PAPER CHANGE	
Printhead	Use isopropyl alcohol
Roller	Use isopropyl alcohol
EVERY 5 PAPER CHANGES	
Paper path	Use compressed air or tweezers
Sensor	Use compressed air
EVERY 6 MONTHS OR AS NEEDED	
Printer case	Use compressed air or a soft cloth

For specific procedures, see the following pages.

NOTE:

If you use the device in dusty environments, you must reduce the intervals between the cleaning operations.

6.3 Cleaning

To periodic cleaning of the device, see the instructions below

Paper path

1

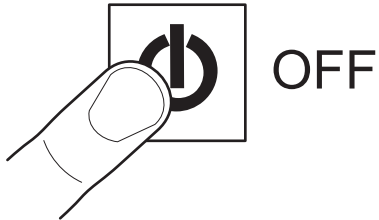

Turn off the device and open the cover.

2

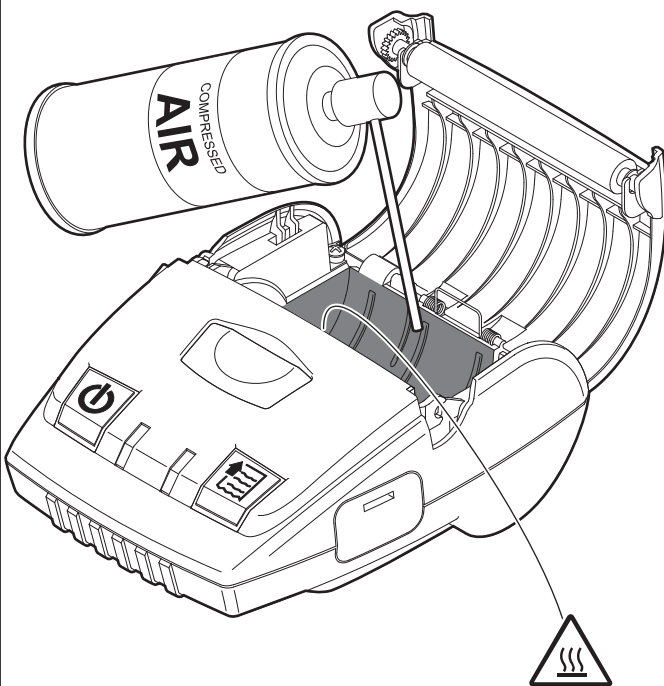

ATTENTION:

Do not use alcohol, solvents, or hard brushes.
Do not let water or other liquids get inside the device.



Clean the area involved in the passage of paper by using compressed air.

Printing roller

1

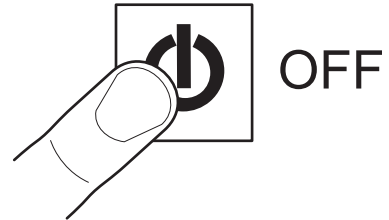

Turn off the device and open the cover.

2

ISOPROPYL ALCOHOL

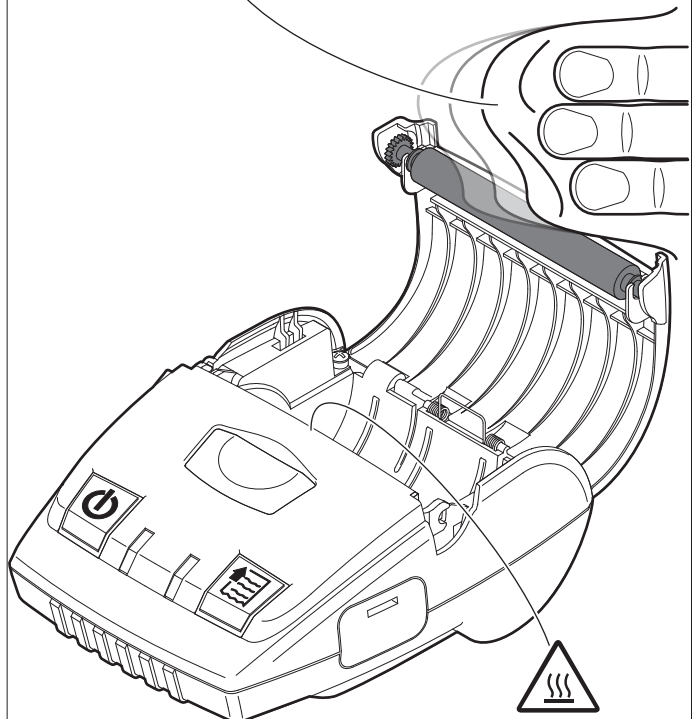

ATTENTION:

Do not use solvents, or hard brushes.
Do not let water or other liquids get inside the machine.



Clean the printing roller by using a non-abrasive cloth moistened with isopropyl.

Sensor

1

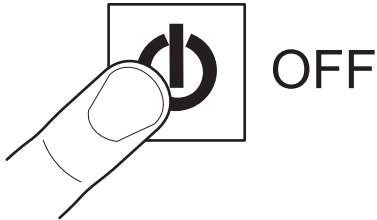

Turn off the device and open the cover.

2

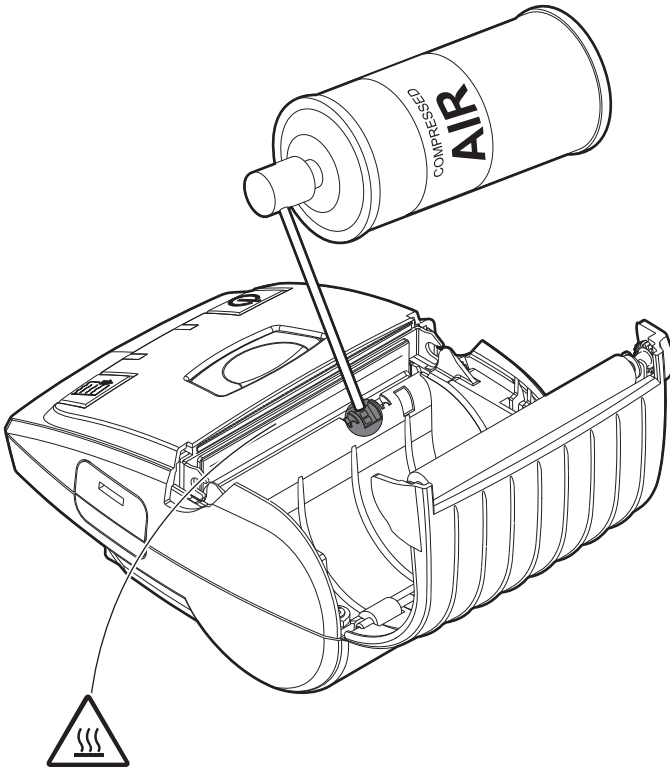

ATTENTION:
Do not use alcohol, solvents, or hard brushes.
Do not let water or other liquids get inside the device.



Clean the device sensor by using compressed air.

Print head

1

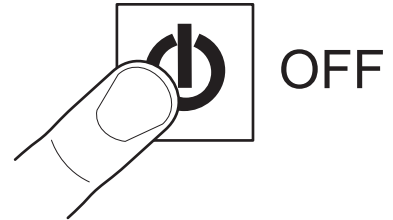

Turn off the device and open the cover.

2

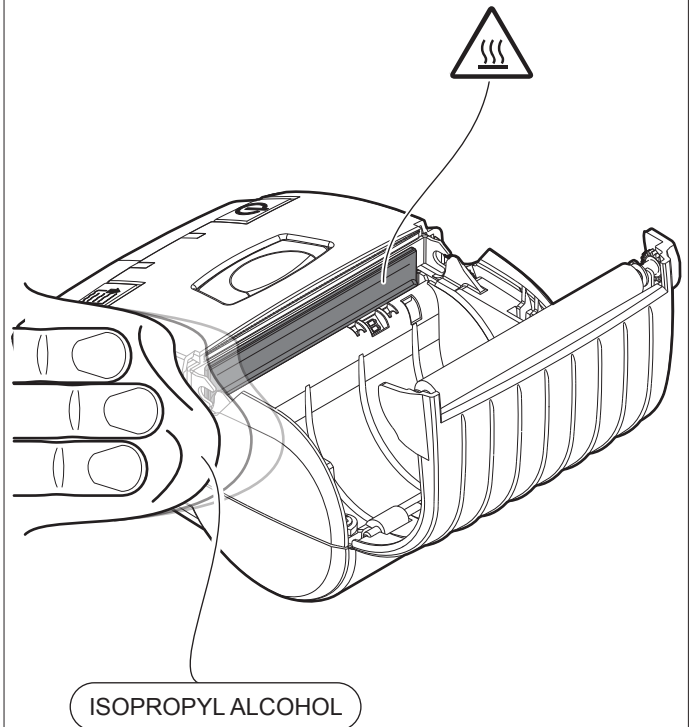

ATTENTION:
Do not use solvents, or hard brushes.
Do not let water or other liquids get inside the machine.



Clean the printing head by using a non-abrasive cloth moistened with isopropyl.

Case

1

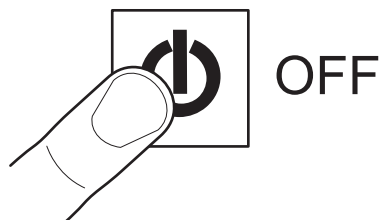

Turn off the device.

2

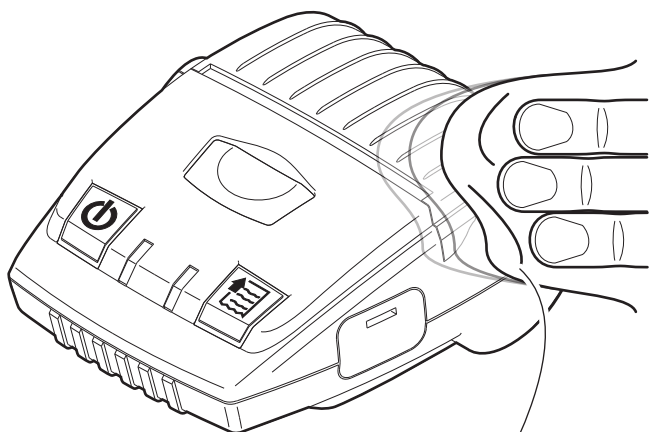

ISOPROPYL ALCOHOL

ATTENTION:

Do not use solvents, or hard brushes.

Do not let water or other liquids get inside the machine.



To clean the device,
use compressed air or a soft cloth.

6.4 Upgrade firmware

WARNING: During communication between PC/device for the firmware update it is strictly forbidden to disconnect the communication cable or to remove the power supply of the devices not to endanger the proper functioning of the device.

NOTES:

The latest firmware of the device is available in the download area of the web site www.custom.biz

Install on the PC used for device upgrading the UPG-CEPRN software available in the download area of the web site www.custom.biz.

NOTE: Before proceeding with the firmware update make sure that the parameter "INTERFACE" has been set as "USB"

6. Switch ON the device.
7. Launch the software UPGCEPRN.
8. Select the update file .PSW location:

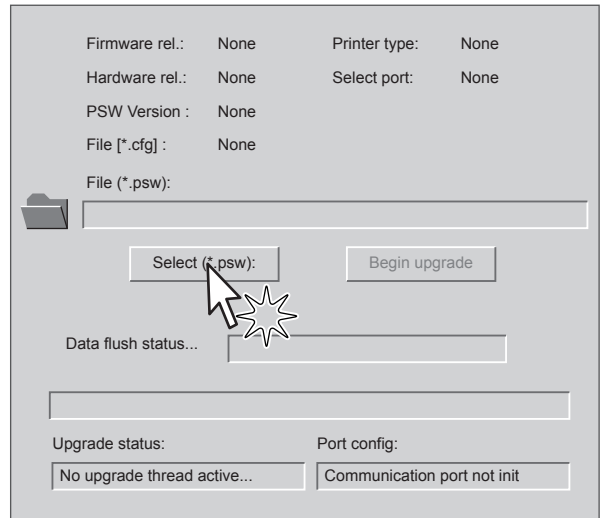

UPDATE VIA USB INTERFACE

ATTENTION:

Only during the firmware update, the connection between PC and device must be direct, without the use of wireless HUB.

Only during the firmware update, do not connect or disconnect other USB devices.

NOTE: For communication via USB you must install on PC the device driver available in the download area of the web site www.custom.biz.

9. Select item USB and then select the USB device among those proposed (e.g. device1):

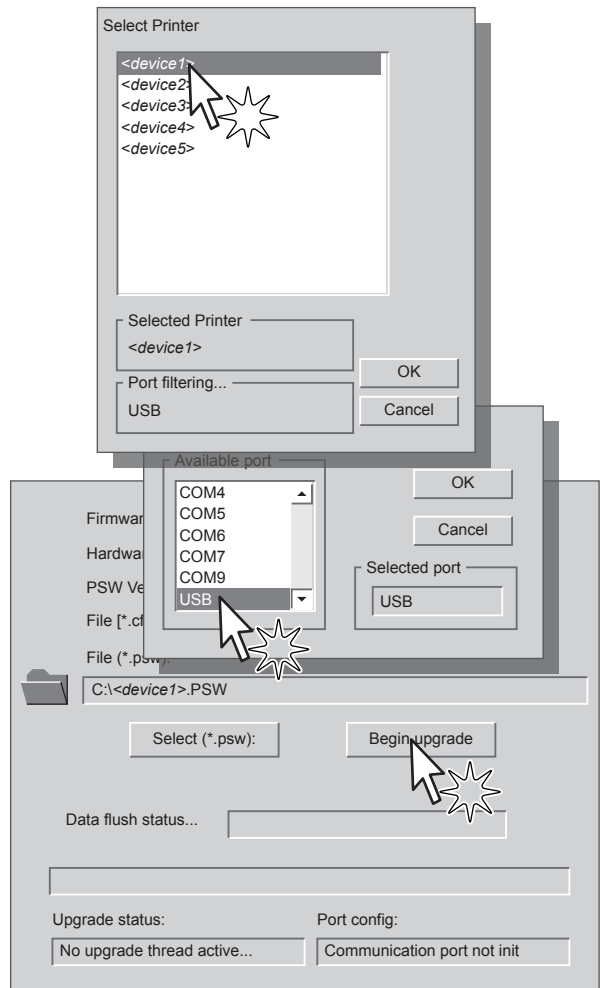

Proceed as follows:

1. Write down the product code (14 digits) printed on the product label (see par. 2.3).
2. Go to the web site www.custom.biz and download the appropriate firmware release from the DOWNLOAD area.
3. Print the SETUP report (see chapter 5).
4. Switch OFF the device.
5. Connect the device to the PC using a USB cable (see paragraph 3.1).

10. After a few minutes a message on the screen warns that the update is completed.

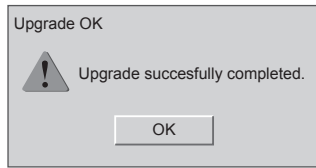

11. Print a new SETUP report to verify the new firmware release (see chapter 5).

7 SPECIFICATION

7.1 Hardware specifications

GENERALS	
Sensors	Head temperature, paper presence
MTBF ⁽¹⁾	740 000 hours
Emulations	CUSTOM/POS
Printing driver	
MY3	Windows XP, Windows VISTA (32/64bit) Windows 7 (32/64bit) Windows 8 (32/64bit) Windows 8.1 (32/64bit) Linux Android
MY3-A	Windows XP, Windows VISTA (32/64bit) Windows 7 (32/64bit) Windows 8 (32/64bit) Windows 8.1 (32/64bit) Linux Android iOS
INTERFACES	
USB connector	USB = 2.0 Full Speed
Bluetooth®	MY3 = Bluetooth® = 2.0 MY3-A = Bluetooth® = 3.0
MEMORIES	
Receive buffer	2 Kbytes
Flash memory	512 Kbytes
RAM memory	96 Kbytes
Graphic memory	4 logos (576 x 460 dots)

DEVICE	
Resolution	203 dpi (8dot/mm)
Printing width	72 mm
Printing method	Thermal fixed head (8 dot/mm)
Printing speed ^{(2) (3) (4)}	Max 80 mm/s
Head life ⁽³⁾	
Abrasion resistance ⁽⁵⁾	100 Km (with recommended paper)
Pulse durability	1 M (12.5% duty cycle)
Printing mode	Normal, 90°, 180°, 270°
Printing format	Height/Width from 1 to 8, bold, reverse, underlined, italic
Character fonts	
MY3	PC437, PC850, PC860, PC863, PC865, PC858 (euro)
MY3-A	PC437, PC850, PC860, PC863, PC865, PC866, PC858 (euro)
Printable barcode	
MY3	UPCA, UPCE, EAN13, EAN8, CODE39, ITF, CODABAR, CODE93, CODE128, CODE32, PDF417, DATAMATRIX, QRCODE
MY3-A	UPCA, UPCE, EAN13, EAN8, CODE39, ITF, CODABAR, CODE93, CODE128, CODE32
PAPER	
Type of paper	Thermal rolls, heat-sensitive side on outside of roll
Paper width	76.2 ± 0.5 mm
Paper weight	from 55 g/m ² to 100 g/m ²
Paper thickness	from 61 µm to 100 µm
Recommended types of paper	KANZAN KF50 and KP460 MITSUBISHI PF5067 and TL4000

Paper end	Not attached to roll core
Roll outer diameter	Max Ø45 mm
Internal roll core diameter	12mm ± 1 mm 25mm ± 1 mm
Core type	Cardboard or plastic

CONNECTABLE DEVICES

PC

Bluetooth® device

DEVICE ELECTRICAL SPECIFICATIONS

Power supply MY3 = 12 Vdc - 24 Vdc ±10% (external power supply 18 V)
MY3-A = 5 Vdc - 24 Vdc ±10% (external power supply 18 V)

Medium consumption ⁽³⁾ 0.3 A

Standby consumption 0.02 A

ELECTRICAL SPECIFICATIONS POWER SUPPLY cod.963GE020000301

Power supply voltage from 100 Vac to 240 Vac

Frequency from 50 Hz to 60 Hz

Output 18 V 1 A

Power 18 W

BATTERIES SPECIFICATIONS cod. 28D30000000005

Battery pack Li-ion 7.4V 1500mAh

Recharge with power supply from 12 Vdc to 24 Vdc (300 mA)

Charging cycle ⁽⁶⁾ Max 3 hours

Autonomy

Print 8 Hours x 750 ticket

Standby USB = 1000 min
Bluetooth® = 1000 min

Input Specification

Input voltage	from 90 Vac to 264 Vac
---------------	------------------------

Current	Max 0.8 A
---------	-----------

Input frequency	from 47 Hz to 63 Hz
-----------------	---------------------

Output specification

Output voltage	24 Vdc
----------------	--------

Output current	from 0.1 A to 1.3 A
----------------	---------------------

Typical efficiency	75 %
--------------------	------

Environmental condition

Operating temperature	from -10°C to 70°C
-----------------------	--------------------

Humidity	from 20 % Rh to 85 % Rh
----------	-------------------------

Storage temperature	from -10°C to 75°C
---------------------	--------------------

Storage humidity	from 10 % Rh to 95 % Rh
------------------	-------------------------

Protection device	Short-circuit, overload
-------------------	-------------------------

ENVIRONMENTAL CONDITIONS

Operating temperature ⁽⁷⁾	from -15°C to 55°C
--------------------------------------	--------------------

Relative humidity	from 10% Rh to 85% Rh
-------------------	-----------------------

Storage temperature	from -20°C to +70°C
---------------------	---------------------

Storage relative humidity	from 10% Rh to 90% Rh
---------------------------	-----------------------

NOTE:

(1) : Electronic board.

(2) : It depends by the battery status, the printing typology and the environmental temperature

(3) : Respecting the regular schedule of cleaning for the device components.

(4) : Standard CUSTOM receipt (L=10cm, Density = 12,5% dots on).

(5) : Damages caused by scratches, ESD and electromigration are excluded.

(6) : With completely discharged batteries

(7) : In charge from 0°C to 45°C

7.2 Character specifications

Character set		3	
Character density	13 cpi	17 cpi	22 cpi
Number of columns	36	48	60/64
Chars / sec	960	1280	1707
Lines / sec	26	26	26
Characters (L x H mm)-Normal	2 x 3	1.5 x 3	1 x 3

NOTE: Theoretical values.

7.3 Device dimensions

Length	with the cover closed 135 mm with the cover opened 168.5 mm
Height	with the cover closed 61 mm with the cover opened 91.5 mm
Width	105 mm
Weight	without paper 320 g with paper 400 g

NOTE: All the dimensions shown in following figures are in millimetres.

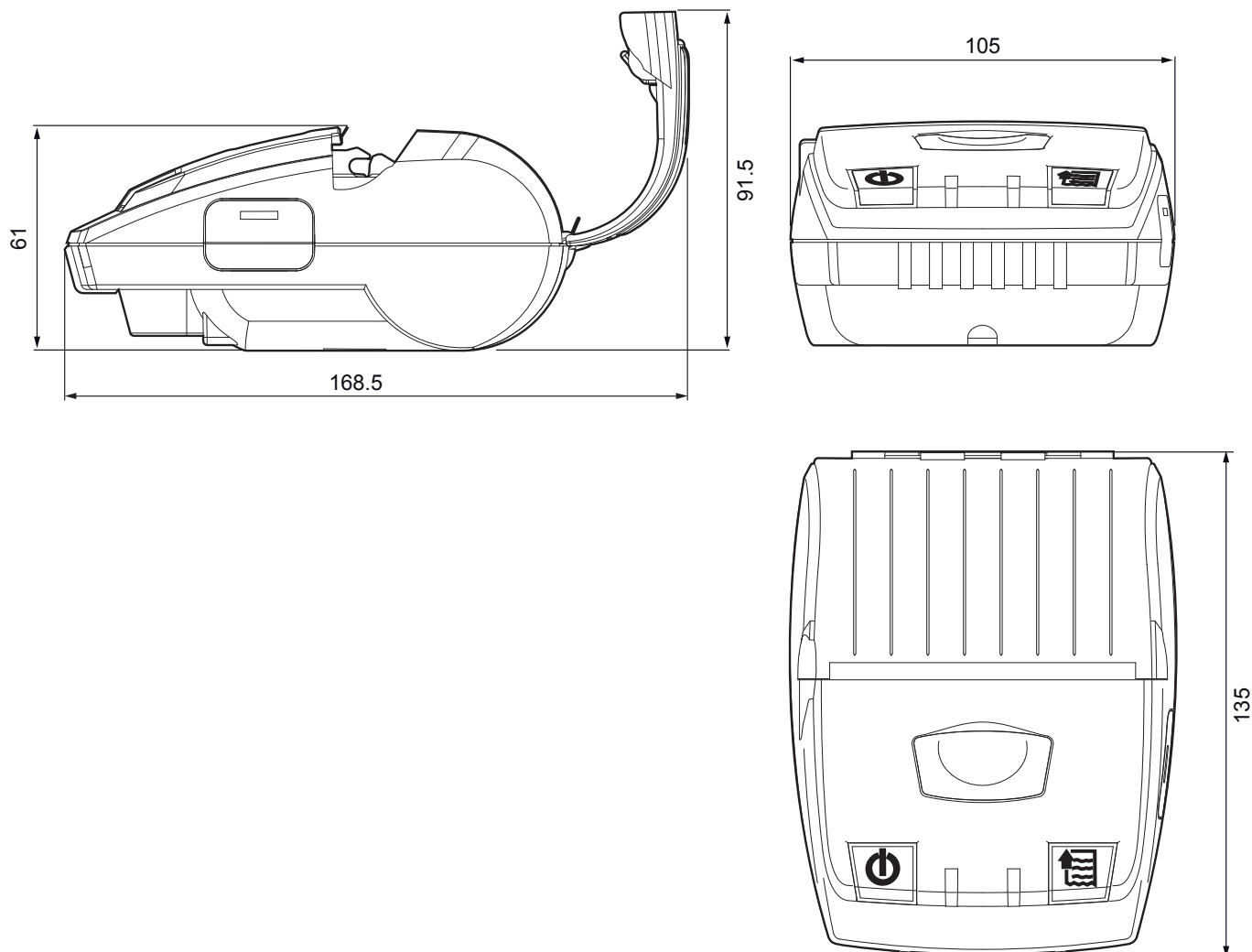

7.4 Power supply dimensions cod. 963GE020000301

Length	74 mm
Height	34 mm
Width	43.5 mm

NOTE: All the dimensions shown in following figures are in millimetres.

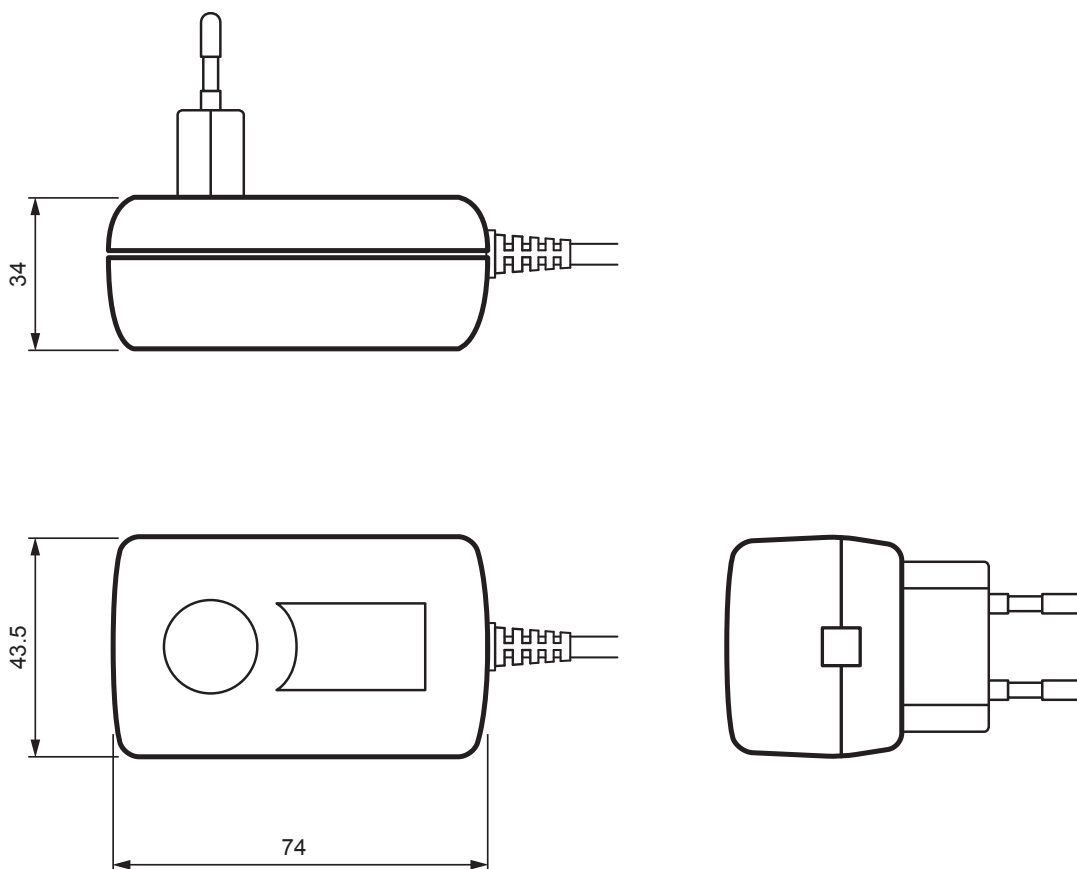

7.5 Paper specification

Paper with black mark

The following image shows the placement of the black mark on the thermal side of the paper.

To more information about the use of paper with black mark see Chapter 10

NOTE: All the dimensions shown in following figures are in millimetres.

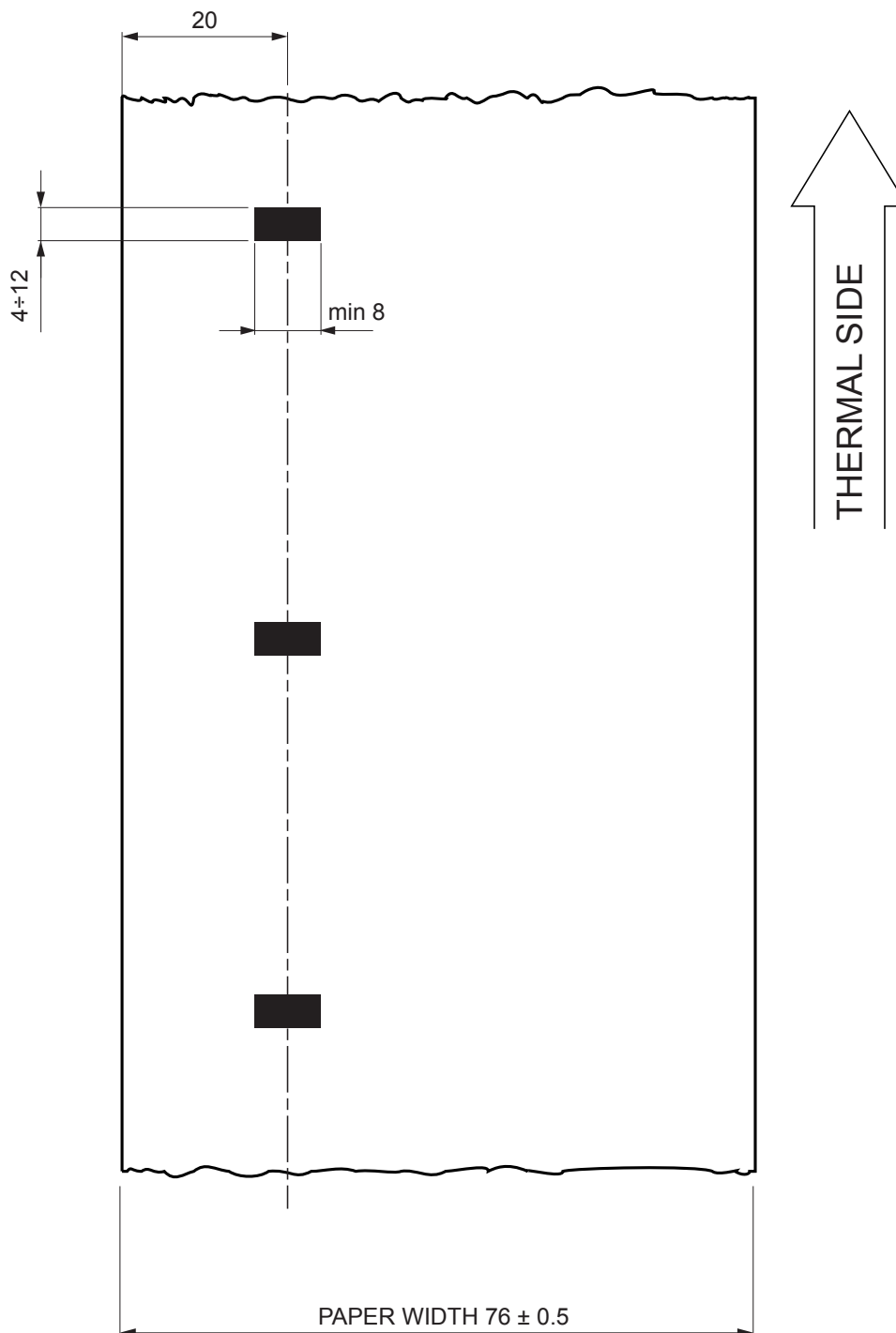

Paper with black mark and label

To properly use the alignment commands, you need to use paper with labels that comply with the dimensions shown in the following figure.

For more information about the use of paper with black mark see Chapter 10.

NOTE: All the dimensions shown in following figures are in millimetres.

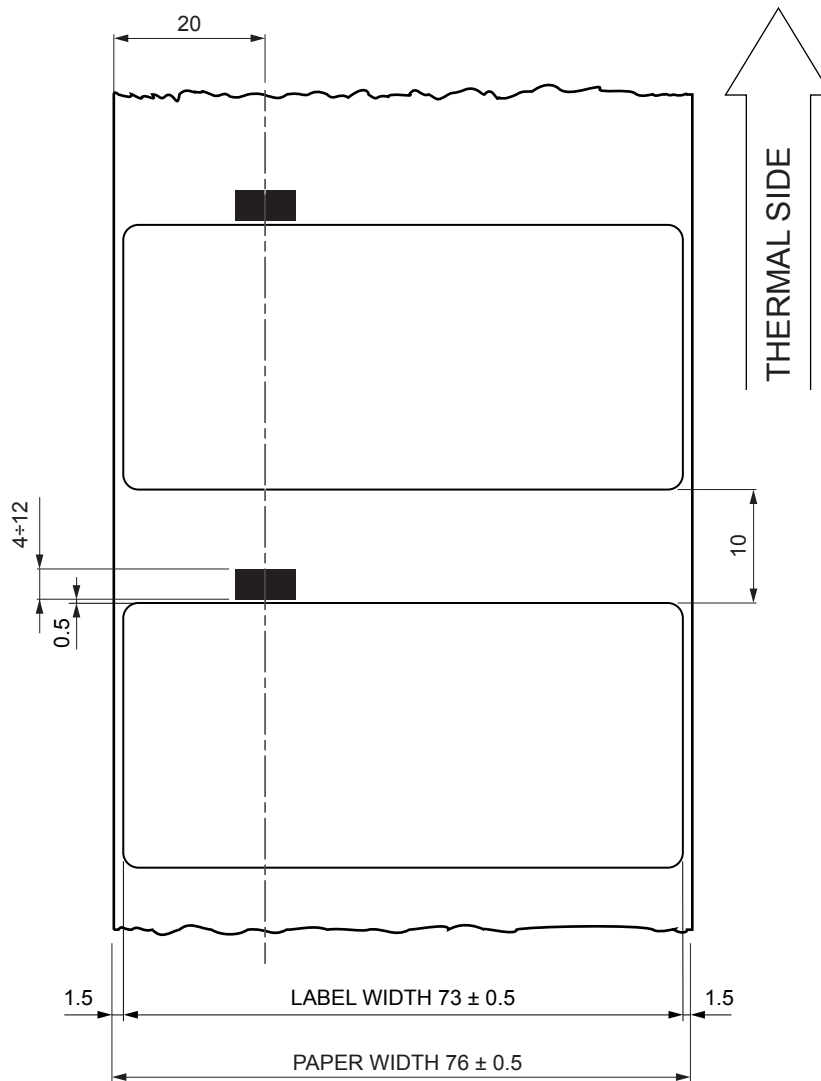

NOTE: Set the "Notch Distance" to 12mm (see Chapter 5).

Paper with hole and label

To properly use the alignment commands, you need to use paper with labels that comply with the dimensions shown in the following figure.

For more information about the use of paper hole see Chapter 10

NOTE: All the dimensions shown in following figures are in millimetres.

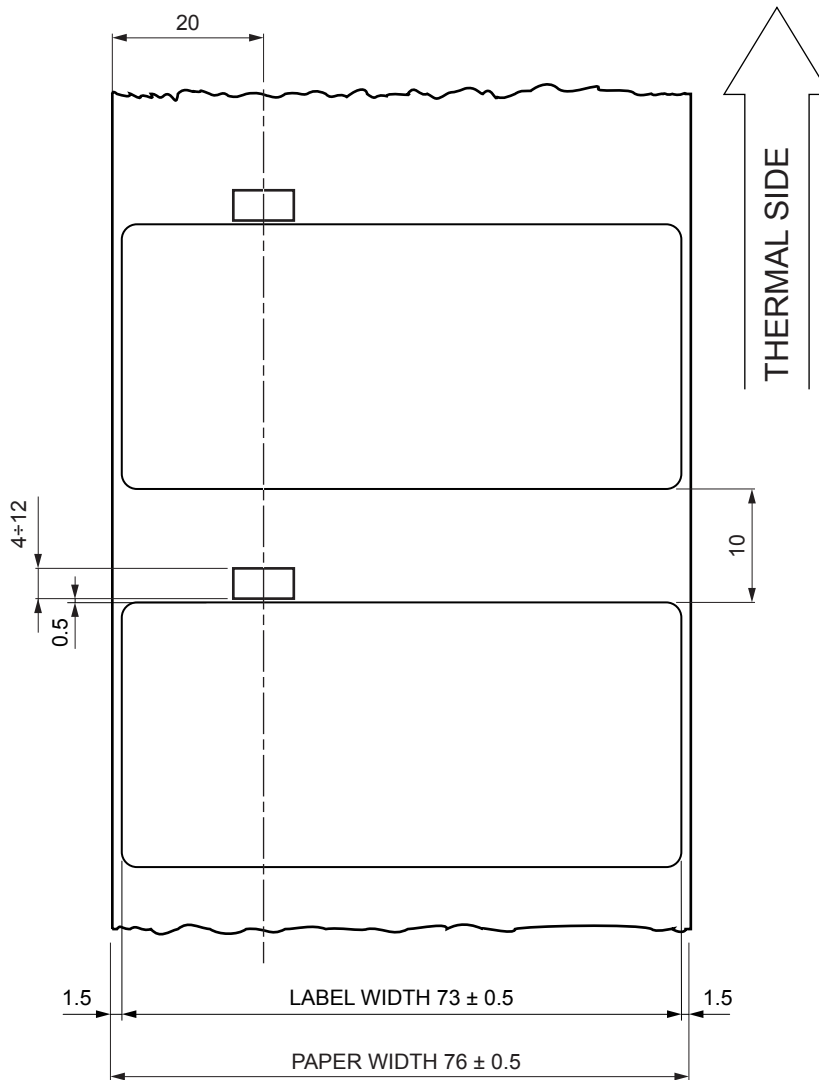



















































NOTE: Set the "Notch Distance" to 12mm (see Chapter 5).



7.6 Western characters

The printer has 3 fonts of varying width (13, 17 and 22 cpi) which may be accessed through programming or control characters. Each of these fonts offers the following code tables: PC437, PC850, PC860, PC863, PC865, PC858, PC866 (only MY3-A model).



PC437 CODE TABLE (Usa, Standard Europe)

Char	SP	!	“	#	\$	%	&	‘	()	*	+	,	-	.	/	
Hex	0020	0021	0022	0023	0024	0025	0026	0027	0028	0029	002A	002B	002C	002D	002E	002F	
Dec	32	33	34	35	36	37	38	39	40	41	42	43	44	45	46	47	
Char	0	1	2	3	4	5	6	7	8	9	:	;	<	=	>	?	
Hex	0030	0031	0032	0033	0034	0035	0036	0037	0038	0039	003A	003B	003C	003D	003E	003F	
Dec	48	49	50	51	52	53	54	55	56	57	58	59	60	61	62	63	
Char	@	A	B	C	D	E	F	G	H	I	J	K	L	M	N	O	
Hex	0040	0041	0042	0043	0044	0045	0046	0047	0048	0049	004A	004B	004C	004D	004E	004F	
Dec	64	65	66	67	68	69	70	71	72	73	74	75	76	77	78	79	
Char	P	Q	R	S	T	U	V	W	X	Y	Z	[\]	^	_	
Hex	0050	0051	0052	0053	0054	0055	0056	0057	0058	0059	005A	005B	005C	005D	005E	005F	
Dec	80	81	82	83	84	85	86	87	88	89	90	91	92	93	94	95	
Char	`	a	b	c	d	e	f	g	h	i	j	k	l	m	n	o	
Hex	0060	0061	0062	0063	0064	0065	0066	0067	0068	0069	006A	006B	006C	006D	006E	006F	
Dec	96	97	98	99	100	101	102	103	104	105	106	107	108	109	110	111	
Char	p	q	r	s	t	u	v	w	x	y	z	{	 	}	~	␣	
Hex	0070	0071	0072	0073	0074	0075	0076	0077	0078	0079	007A	007B	007C	007D	007E	007F	
Dec	112	113	114	115	116	117	118	119	120	121	122	123	124	125	126	127	
Char	Ç	ü	é	â	ä	à	å	ç	ê	ë	è	ï	î	ì	Ä	Å	
Hex	0080	0081	0082	0083	0084	0085	0086	0087	0088	0089	008A	008B	008C	008D	008E	008F	
Dec	128	129	130	131	132	133	134	135	136	137	138	139	140	141	142	143	
Char	É	æ	Æ	ô	ö	ò	û	ù	ÿ	Ö	Ü	ç	£	¥	Pts	f	
Hex	0090	0091	0092	0093	0094	0095	0096	0097	0098	0099	009A	009B	009C	009D	009E	009F	
Dec	144	145	146	147	148	149	150	151	152	153	154	155	156	157	158	159	
Char	á	í	ó	ú	ñ	Ñ	a	o	¿	¡	½	¼	¡	«	»		
Hex	00A0	00A1	00A2	00A3	00A4	00A5	00A6	00A7	00A8	00A9	00AA	00AB	00AC	00AD	00AE	00AF	
Dec	160	161	162	163	164	165	166	167	168	169	170	171	172	173	174	175	
Char																	
Hex	00B0	00B1	00B2	00B3	00B4	00B5	00B6	00B7	00B8	00B9	00BA	00BB	00BC	00BD	00BE	00BF	
Dec	176	177	178	179	180	181	182	183	184	185	186	187	188	189	190	191	
Char																	
Hex	00C0	00C1	00C2	00C3	00C4	00C5	00C6	00C7	00C8	00C9	00CA	00CB	00CC	00CD	00CE	00CF	
Dec	192	193	194	195	196	197	198	199	200	201	202	203	204	205	206	207	
Char																	
Hex	00D0	00D1	00D2	00D3	00D4	00D5	00D6	00D7	00D8	00D9	00DA	00DB	00DC	00DD	00DE	00DF	
Dec	208	209	210	211	212	213	214	215	216	217	218	219	220	221	222	223	
Char	α	β	Γ	π	Σ	σ	μ	τ	Φ	Θ	Ω	δ	∞	φ	ε	∩	
Hex	00E0	00E1	00E2	00E3	00E4	00E5	00E6	00E7	00E8	00E9	00EA	00EB	00EC	00ED	00EE	00EF	
Dec	224	225	226	227	228	229	230	231	232	233	234	235	236	237	238	239	
Char	≡	±	≥	≤	∫	∫	÷	≈	°	·	·	√	n	²	■	NBSP	
Hex	00F0	00F1	00F2	00F3	00F4	00F5	00F6	00F7	00F8	00F9	00FA	00FB	00FC	00FD	00FE	00FF	
Dec	240	241	242	243	244	245	246	247	248	249	250	251	252	253	254	255	



















































PC850 CODE TABLE (Multilingual)

Char	SP	!	“	#	\$	%	&	‘	()	*	+	,	-	.	/	
Hex	0020	0021	0022	0023	0024	0025	0026	0027	0028	0029	002A	002B	002C	002D	002E	002F	
Dec	32	33	34	35	36	37	38	39	40	41	42	43	44	45	46	47	
Char	0	1	2	3	4	5	6	7	8	9	:	;	<	=	>	?	
Hex	0030	0031	0032	0033	0034	0035	0036	0037	0038	0039	003A	003B	003C	003D	003E	003F	
Dec	48	49	50	51	52	53	54	55	56	57	58	59	60	61	62	63	
Char	@	A	B	C	D	E	F	G	H	I	J	K	L	M	N	O	
Hex	0040	0041	0042	0043	0044	0045	0046	0047	0048	0049	004A	004B	004C	004D	004E	004F	
Dec	64	65	66	67	68	69	70	71	72	73	74	75	76	77	78	79	
Char	P	Q	R	S	T	U	V	W	X	Y	Z	[\]	^	_	
Hex	0050	0051	0052	0053	0054	0055	0056	0057	0058	0059	005A	005B	005C	005D	005E	005F	
Dec	80	81	82	83	84	85	86	87	88	89	90	91	92	93	94	95	
Char	`	a	b	c	d	e	f	g	h	i	j	k	l	m	n	o	
Hex	0060	0061	0062	0063	0064	0065	0066	0067	0068	0069	006A	006B	006C	006D	006E	006F	
Dec	96	97	98	99	100	101	102	103	104	105	106	107	108	109	110	111	
Char	p	q	r	s	t	u	v	w	x	y	z	{	 	}	~	␣	
Hex	0070	0071	0072	0073	0074	0075	0076	0077	0078	0079	007A	007B	007C	007D	007E	007F	
Dec	112	113	114	115	116	117	118	119	120	121	122	123	124	125	126	127	
Char	Ç	ü	é	â	ä	à	å	ç	ê	ë	è	ï	î	ì	Ä	Å	
Hex	0080	0081	0082	0083	0084	0085	0086	0087	0088	0089	008A	008B	008C	008D	008E	008F	
Dec	128	129	130	131	132	133	134	135	136	137	138	139	140	141	142	143	
Char	É	æ	Æ	ô	ö	ò	û	ù	ÿ	Ö	Ü	ø	£	Ø	×	f	
Hex	0090	0091	0092	0093	0094	0095	0096	0097	0098	0099	009A	009B	009C	009D	009E	009F	
Dec	144	145	146	147	148	149	150	151	152	153	154	155	156	157	158	159	
Char	á	í	ó	ú	ñ	Ñ	ª	º	¿	®	¬	½	¼	¡	«	»	
Hex	00A0	00A1	00A2	00A3	00A4	00A5	00A6	00A7	00A8	00A9	00AA	00AB	00AC	00AD	00AE	00AF	
Dec	160	161	162	163	164	165	166	167	168	169	170	171	172	173	174	175	
Char				 	†	Á	Â	À	©	¶	 	¶	¶	¶	¢	¥	¬
Hex	00B0	00B1	00B2	00B3	00B4	00B5	00B6	00B7	00B8	00B9	00BA	00BB	00BC	00BD	00BE	00BF	
Dec	176	177	178	179	180	181	182	183	184	185	186	187	188	189	190	191	
Char	Ł	ł	Ŧ	ŧ	—	†	ã	Ã	ℒ	℞	℥	℥	℥	℥	=	¶	¤
Hex	00C0	00C1	00C2	00C3	00C4	00C5	00C6	00C7	00C8	00C9	00CA	00CB	00CC	00CD	00CE	00CF	
Dec	192	193	194	195	196	197	198	199	200	201	202	203	204	205	206	207	
Char	ð	Đ	Ê	Ë	È	ı	Í	Î	İ	Ј	Г	■	■	ı	ì	■	
Hex	00D0	00D1	00D2	00D3	00D4	00D5	00D6	00D7	00D8	00D9	00DA	00DB	00DC	00DD	00DE	00DF	
Dec	208	209	210	211	212	213	214	215	216	217	218	219	220	221	222	223	
Char	Ó	ß	Ô	Ò	õ	Õ	µ	þ	Ɔ	Ú	Û	Ù	ý	Ý	ˉ	˘	
Hex	00E0	00E1	00E2	00E3	00E4	00E5	00E6	00E7	00E8	00E9	00EA	00EB	00EC	00ED	00EE	00EF	
Dec	224	225	226	227	228	229	230	231	232	233	234	235	236	237	238	239	
Char	SHY	±	=	¾	¶	§	÷	˘	°	ˆ	˙	1	3	2	■	NBSP	
Hex	00F0	00F1	00F2	00F3	00F4	00F5	00F6	00F7	00F8	00F9	00FA	00FB	00FC	00FD	00FE	00FF	
Dec	240	241	242	243	244	245	246	247	248	249	250	251	252	253	254	255	

PC860 CODE TABLE (Portuguese)

Char	SP	!	“	#	\$	%	&	‘	()	*	+	,	-	.	/
Hex	0020	0021	0022	0023	0024	0025	0026	0027	0028	0029	002A	002B	002C	002D	002E	002F
Dec	32	33	34	35	36	37	38	39	40	41	42	43	44	45	46	47
Char	0	1	2	3	4	5	6	7	8	9	:	;	<	=	>	?
Hex	0030	0031	0032	0033	0034	0035	0036	0037	0038	0039	003A	003B	003C	003D	003E	003F
Dec	48	49	50	51	52	53	54	55	56	57	58	59	60	61	62	63
Char	@	A	B	C	D	E	F	G	H	I	J	K	L	M	N	O
Hex	0040	0041	0042	0043	0044	0045	0046	0047	0048	0049	004A	004B	004C	004D	004E	004F
Dec	64	65	66	67	68	69	70	71	72	73	74	75	76	77	78	79
Char	P	Q	R	S	T	U	V	W	X	Y	Z	[\]	^	_
Hex	0050	0051	0052	0053	0054	0055	0056	0057	0058	0059	005A	005B	005C	005D	005E	005F
Dec	80	81	82	83	84	85	86	87	88	89	90	91	92	93	94	95
Char	`	a	b	c	d	e	f	g	h	i	j	k	l	m	n	o
Hex	0060	0061	0062	0063	0064	0065	0066	0067	0068	0069	006A	006B	006C	006D	006E	006F
Dec	96	97	98	99	100	101	102	103	104	105	106	107	108	109	110	111
Char	p	q	r	s	t	u	v	w	x	y	z	{	 	}	~	␣
Hex	0070	0071	0072	0073	0074	0075	0076	0077	0078	0079	007A	007B	007C	007D	007E	007F
Dec	112	113	114	115	116	117	118	119	120	121	122	123	124	125	126	127
Char	Ç	ü	é	â	ã	à	Á	ç	ê	Ê	è	í	Ô	ì	Ã	Â
Hex	0080	0081	0082	0083	0084	0085	0086	0087	0088	0089	008A	008B	008C	008D	008E	008F
Dec	128	129	130	131	132	133	134	135	136	137	138	139	140	141	142	143
Char	É	À	È	ô	ö	ò	Ú	ù	ì	Õ	Ü	ç	£	Ù	Þ	Ó
Hex	0090	0091	0092	0093	0094	0095	0096	0097	0098	0099	009A	009B	009C	009D	009E	009F
Dec	144	145	146	147	148	149	150	151	152	153	154	155	156	157	158	159
Char	á	í	ó	ú	ñ	Ñ	ª	º	¿	Ò	¬	½	¼	¡	«	»
Hex	00A0	00A1	00A2	00A3	00A4	00A5	00A6	00A7	00A8	00A9	00AA	00AB	00AC	00AD	00AE	00AF
Dec	160	161	162	163	164	165	166	167	168	169	170	171	172	173	174	175
Char																
Hex	00B0	00B1	00B2	00B3	00B4	00B5	00B6	00B7	00B8	00B9	00BA	00BB	00BC	00BD	00BE	00BF
Dec	176	177	178	179	180	181	182	183	184	185	186	187	188	189	190	191
Char	L	L	T		—	+	F		L	F	±	¶		=	¶	±
Hex	00C0	00C1	00C2	00C3	00C4	00C5	00C6	00C7	00C8	00C9	00CA	00CB	00CC	00CD	00CE	00CF
Dec	192	193	194	195	196	197	198	199	200	201	202	203	204	205	206	207
Char	±	¶	π	L	L	F	π	±	±	J	Γ	■	■	■	■	■
Hex	00D0	00D1	00D2	00D3	00D4	00D5	00D6	00D7	00D8	00D9	00DA	00DB	00DC	00DD	00DE	00DF
Dec	208	209	210	211	212	213	214	215	216	217	218	219	220	221	222	223
Char	α	β	Γ	π	Σ	σ	μ	τ	Φ	Θ	Ω	δ	∞	φ	ε	∩
Hex	00E0	00E1	00E2	00E3	00E4	00E5	00E6	00E7	00E8	00E9	00EA	00EB	00EC	00ED	00EE	00EF
Dec	224	225	226	227	228	229	230	231	232	233	234	235	236	237	238	239
Char	≡	±	≥	≤		J	÷	≈	°	·	·	√	n	²	■	NBSP
Hex	00F0	00F1	00F2	00F3	00F4	00F5	00F6	00F7	00F8	00F9	00FA	00FB	00FC	00FD	00FE	00FF
Dec	240	241	242	243	244	245	246	247	248	249	250	251	252	253	254	255



PC863 CODE TABLE (Canadian, French)

Char	SP	!	“	#	\$	%	&	‘	()	*	+	,	-	.	/	
Hex	0020	0021	0022	0023	0024	0025	0026	0027	0028	0029	002A	002B	002C	002D	002E	002F	
Dec	32	33	34	35	36	37	38	39	40	41	42	43	44	45	46	47	
Char	0	1	2	3	4	5	6	7	8	9	:	;	<	=	>	?	
Hex	0030	0031	0032	0033	0034	0035	0036	0037	0038	0039	003A	003B	003C	003D	003E	003F	
Dec	48	49	50	51	52	53	54	55	56	57	58	59	60	61	62	63	
Char	@	A	B	C	D	E	F	G	H	I	J	K	L	M	N	O	
Hex	0040	0041	0042	0043	0044	0045	0046	0047	0048	0049	004A	004B	004C	004D	004E	004F	
Dec	64	65	66	67	68	69	70	71	72	73	74	75	76	77	78	79	
Char	P	Q	R	S	T	U	V	W	X	Y	Z	[\]	^	_	
Hex	0050	0051	0052	0053	0054	0055	0056	0057	0058	0059	005A	005B	005C	005D	005E	005F	
Dec	80	81	82	83	84	85	86	87	88	89	90	91	92	93	94	95	
Char	`	a	b	c	d	e	f	g	h	i	j	k	l	m	n	o	
Hex	0060	0061	0062	0063	0064	0065	0066	0067	0068	0069	006A	006B	006C	006D	006E	006F	
Dec	96	97	98	99	100	101	102	103	104	105	106	107	108	109	110	111	
Char	p	q	r	s	t	u	v	w	x	y	z	{	 	}	~	␣	
Hex	0070	0071	0072	0073	0074	0075	0076	0077	0078	0079	007A	007B	007C	007D	007E	007F	
Dec	112	113	114	115	116	117	118	119	120	121	122	123	124	125	126	127	
Char	Ç	ü	é	â	Â	à	¶	ç	ê	ë	è	ï	î	=	À	§	
Hex	0080	0081	0082	0083	0084	0085	0086	0087	0088	0089	008A	008B	008C	008D	008E	008F	
Dec	128	129	130	131	132	133	134	135	136	137	138	139	140	141	142	143	
Char	É	È	Ê	ô	Ë	ï	û	ù	¤	Ô	Ü	¢	£	Ù	Û	f	
Hex	0090	0091	0092	0093	0094	0095	0096	0097	0098	0099	009A	009B	009C	009D	009E	009F	
Dec	144	145	146	147	148	149	150	151	152	153	154	155	156	157	158	159	
Char	¡	´	ó	ú	¨	¸	³	—	î	ƒ	¬	½	¼	¾	«	»	
Hex	00A0	00A1	00A2	00A3	00A4	00A5	00A6	00A7	00A8	00A9	00AA	00AB	00AC	00AD	00AE	00AF	
Dec	160	161	162	163	164	165	166	167	168	169	170	171	172	173	174	175	
Char																	
Hex	00B0	00B1	00B2	00B3	00B4	00B5	00B6	00B7	00B8	00B9	00BA	00BB	00BC	00BD	00BE	00BF	
Dec	176	177	178	179	180	181	182	183	184	185	186	187	188	189	190	191	
Char																	
Hex	00C0	00C1	00C2	00C3	00C4	00C5	00C6	00C7	00C8	00C9	00CA	00CB	00CC	00CD	00CE	00CF	
Dec	192	193	194	195	196	197	198	199	200	201	202	203	204	205	206	207	
Char																	
Hex	00D0	00D1	00D2	00D3	00D4	00D5	00D6	00D7	00D8	00D9	00DA	00DB	00DC	00DD	00DE	00DF	
Dec	208	209	210	211	212	213	214	215	216	217	218	219	220	221	222	223	
Char	α	β	Γ	π	Σ	σ	μ	τ	Φ	Θ	Ω	δ	∞	φ	ε	∩	
Hex	00E0	00E1	00E2	00E3	00E4	00E5	00E6	00E7	00E8	00E9	00EA	00EB	00EC	00ED	00EE	00EF	
Dec	224	225	226	227	228	229	230	231	232	233	234	235	236	237	238	239	
Char	≡	±	≥	≤	∫	∫	÷	≈	°	·	·	√	n	²	■	NBSP	
Hex	00F0	00F1	00F2	00F3	00F4	00F5	00F6	00F7	00F8	00F9	00FA	00FB	00FC	00FD	00FE	00FF	
Dec	240	241	242	243	244	245	246	247	248	249	250	251	252	253	254	255	

PC865 CODE TABLE (Nordic)

Char	SP	!	“	#	\$	%	&	‘	()	*	+	,	-	.	/
Hex	0020	0021	0022	0023	0024	0025	0026	0027	0028	0029	002A	002B	002C	002D	002E	002F
Dec	32	33	34	35	36	37	38	39	40	41	42	43	44	45	46	47
Char	0	1	2	3	4	5	6	7	8	9	:	;	<	=	>	?
Hex	0030	0031	0032	0033	0034	0035	0036	0037	0038	0039	003A	003B	003C	003D	003E	003F
Dec	48	49	50	51	52	53	54	55	56	57	58	59	60	61	62	63
Char	@	A	B	C	D	E	F	G	H	I	J	K	L	M	N	O
Hex	0040	0041	0042	0043	0044	0045	0046	0047	0048	0049	004A	004B	004C	004D	004E	004F
Dec	64	65	66	67	68	69	70	71	72	73	74	75	76	77	78	79
Char	P	Q	R	S	T	U	V	W	X	Y	Z	[\]	^	_
Hex	0050	0051	0052	0053	0054	0055	0056	0057	0058	0059	005A	005B	005C	005D	005E	005F
Dec	80	81	82	83	84	85	86	87	88	89	90	91	92	93	94	95
Char	`	a	b	c	d	e	f	g	h	i	j	k	l	m	n	o
Hex	0060	0061	0062	0063	0064	0065	0066	0067	0068	0069	006A	006B	006C	006D	006E	006F
Dec	96	97	98	99	100	101	102	103	104	105	106	107	108	109	110	111
Char	p	q	r	s	t	u	v	w	x	y	z	{	 	}	~	␣
Hex	0070	0071	0072	0073	0074	0075	0076	0077	0078	0079	007A	007B	007C	007D	007E	007F
Dec	112	113	114	115	116	117	118	119	120	121	122	123	124	125	126	127
Char	Ç	ü	é	â	ä	à	å	ç	ê	ë	è	ï	î	ì	Ä	Å
Hex	0080	0081	0082	0083	0084	0085	0086	0087	0088	0089	008A	008B	008C	008D	008E	008F
Dec	128	129	130	131	132	133	134	135	136	137	138	139	140	141	142	143
Char	É	æ	Æ	ô	ö	ò	û	ù	ÿ	Ö	Ü	ø	£	Ø	Þ	ƒ
Hex	0090	0091	0092	0093	0094	0095	0096	0097	0098	0099	009A	009B	009C	009D	009E	009F
Dec	144	145	146	147	148	149	150	151	152	153	154	155	156	157	158	159
Char	á	í	ó	ú	ñ	Ñ	ª	º	¿	¬	¬	½	¼	¡	«	»
Hex	00A0	00A1	00A2	00A3	00A4	00A5	00A6	00A7	00A8	00A9	00AA	00AB	00AC	00AD	00AE	00AF
Dec	160	161	162	163	164	165	166	167	168	169	170	171	172	173	174	175
Char																
Hex	00B0	00B1	00B2	00B3	00B4	00B5	00B6	00B7	00B8	00B9	00BA	00BB	00BC	00BD	00BE	00BF
Dec	176	177	178	179	180	181	182	183	184	185	186	187	188	189	190	191
Char	L	L	T		—	+	F		L	F	±	T		=	±	±
Hex	00C0	00C1	00C2	00C3	00C4	00C5	00C6	00C7	00C8	00C9	00CA	00CB	00CC	00CD	00CE	00CF
Dec	192	193	194	195	196	197	198	199	200	201	202	203	204	205	206	207
Char	±	T	π	L	L	F	π	±	±	J	Γ	■	■	■	■	■
Hex	00D0	00D1	00D2	00D3	00D4	00D5	00D6	00D7	00D8	00D9	00DA	00DB	00DC	00DD	00DE	00DF
Dec	208	209	210	211	212	213	214	215	216	217	218	219	220	221	222	223
Char	α	β	Γ	π	Σ	σ	μ	τ	Φ	Θ	Ω	δ	∞	φ	ε	∩
Hex	00E0	00E1	00E2	00E3	00E4	00E5	00E6	00E7	00E8	00E9	00EA	00EB	00EC	00ED	00EE	00EF
Dec	224	225	226	227	228	229	230	231	232	233	234	235	236	237	238	239
Char	≡	±	≥	≤	 	J	÷	≈	°	·	·	√	n	²	■	NBSP
Hex	00F0	00F1	00F2	00F3	00F4	00F5	00F6	00F7	00F8	00F9	00FA	00FB	00FC	00FD	00FE	00FF
Dec	240	241	242	243	244	245	246	247	248	249	250	251	252	253	254	255

PC858 CODE TABLE (Euro symbol)

Char	SP	!	“	#	\$	%	&	‘	()	*	+	,	-	.	/	
Hex	0020	0021	0022	0023	0024	0025	0026	0027	0028	0029	002A	002B	002C	002D	002E	002F	
Dec	32	33	34	35	36	37	38	39	40	41	42	43	44	45	46	47	
Char	0	1	2	3	4	5	6	7	8	9	:	;	<	=	>	?	
Hex	0030	0031	0032	0033	0034	0035	0036	0037	0038	0039	003A	003B	003C	003D	003E	003F	
Dec	48	49	50	51	52	53	54	55	56	57	58	59	60	61	62	63	
Char	@	A	B	C	D	E	F	G	H	I	J	K	L	M	N	O	
Hex	0040	0041	0042	0043	0044	0045	0046	0047	0048	0049	004A	004B	004C	004D	004E	004F	
Dec	64	65	66	67	68	69	70	71	72	73	74	75	76	77	78	79	
Char	P	Q	R	S	T	U	V	W	X	Y	Z	[\]	^	_	
Hex	0050	0051	0052	0053	0054	0055	0056	0057	0058	0059	005A	005B	005C	005D	005E	005F	
Dec	80	81	82	83	84	85	86	87	88	89	90	91	92	93	94	95	
Char	`	a	b	c	d	e	f	g	h	i	j	k	l	m	n	o	
Hex	0060	0061	0062	0063	0064	0065	0066	0067	0068	0069	006A	006B	006C	006D	006E	006F	
Dec	96	97	98	99	100	101	102	103	104	105	106	107	108	109	110	111	
Char	p	q	r	s	t	u	v	w	x	y	z	{	 	}	~	␣	
Hex	0070	0071	0072	0073	0074	0075	0076	0077	0078	0079	007A	007B	007C	007D	007E	007F	
Dec	112	113	114	115	116	117	118	119	120	121	122	123	124	125	126	127	
Char	Ç	ü	é	â	ä	à	å	ç	ê	ë	è	ï	î	ì	Ä	Å	
Hex	0080	0081	0082	0083	0084	0085	0086	0087	0088	0089	008A	008B	008C	008D	008E	008F	
Dec	128	129	130	131	132	133	134	135	136	137	138	139	140	141	142	143	
Char	É	æ	Æ	ô	ö	ò	û	ù	ÿ	Ö	Ü	ø	£	Ø	×	f	
Hex	0090	0091	0092	0093	0094	0095	0096	0097	0098	0099	009A	009B	009C	009D	009E	009F	
Dec	144	145	146	147	148	149	150	151	152	153	154	155	156	157	158	159	
Char	á	í	ó	ú	ñ	Ñ	ª	º	¿	®	¬	½	¼	¡	«	»	
Hex	00A0	00A1	00A2	00A3	00A4	00A5	00A6	00A7	00A8	00A9	00AA	00AB	00AC	00AD	00AE	00AF	
Dec	160	161	162	163	164	165	166	167	168	169	170	171	172	173	174	175	
Char				 	†	Á	Â	À	©	¶	 	¶	¶	¶	¢	¥	¬
Hex	00B0	00B1	00B2	00B3	00B4	00B5	00B6	00B7	00B8	00B9	00BA	00BB	00BC	00BD	00BE	00BF	
Dec	176	177	178	179	180	181	182	183	184	185	186	187	188	189	190	191	
Char	Ł	ł	Ŧ	ŧ	—	†	ã	Ã	ℒ	℞	℥	℥	℥	℥	=	¶	¤
Hex	00C0	00C1	00C2	00C3	00C4	00C5	00C6	00C7	00C8	00C9	00CA	00CB	00CC	00CD	00CE	00CF	
Dec	192	193	194	195	196	197	198	199	200	201	202	203	204	205	206	207	
Char	ð	Đ	Ê	Ë	È	€	Í	Î	Ï	Ɔ	Ɔ	■	■	¡	ì	■	
Hex	00D0	00D1	00D2	00D3	00D4	00D5	00D6	00D7	00D8	00D9	00DA	00DB	00DC	00DD	00DE	00DF	
Dec	208	209	210	211	212	213	214	215	216	217	218	219	220	221	222	223	
Char	Ó	ß	Ô	Ò	õ	Õ	µ	þ	Ɔ	Ú	Û	Ù	ý	Ý	ˉ	˘	
Hex	00E0	00E1	00E2	00E3	00E4	00E5	00E6	00E7	00E8	00E9	00EA	00EB	00EC	00ED	00EE	00EF	
Dec	224	225	226	227	228	229	230	231	232	233	234	235	236	237	238	239	
Char	SHY	±	=	¾	¶	§	÷	˘	°	ˆ	˙	1	3	2	■	NBSP	
Hex	00F0	00F1	00F2	00F3	00F4	00F5	00F6	00F7	00F8	00F9	00FA	00FB	00FC	00FD	00FE	00FF	
Dec	240	241	242	243	244	245	246	247	248	249	250	251	252	253	254	255	

NOTE: To print the Euro (€) symbol, the command sequence is: 0x1B, 0x74, 0x13, 0xD5 (see Commands Manual).

PC866 CODE TABLE (Cyrillic) (only MY3-A model)

Char	SP	!	“	#	\$	%	&	‘	()	*	+	,	-	.	/
Hex	0020	0021	0022	0023	0024	0025	0026	0027	0028	0029	002A	002B	002C	002D	002E	002F
Dec	32	33	34	35	36	37	38	39	40	41	42	43	44	45	46	47
Char	0	1	2	3	4	5	6	7	8	9	:	;	<	=	>	?
Hex	0030	0031	0032	0033	0034	0035	0036	0037	0038	0039	003A	003B	003C	003D	003E	003F
Dec	48	49	50	51	52	53	54	55	56	57	58	59	60	61	62	63
Char	@	A	B	C	D	E	F	G	H	I	J	K	L	M	N	O
Hex	0040	0041	0042	0043	0044	0045	0046	0047	0048	0049	004A	004B	004C	004D	004E	004F
Dec	64	65	66	67	68	69	70	71	72	73	74	75	76	77	78	79
Char	P	Q	R	S	T	U	V	W	X	Y	Z	[\]	^	_
Hex	0050	0051	0052	0053	0054	0055	0056	0057	0058	0059	005A	005B	005C	005D	005E	005F
Dec	80	81	82	83	84	85	86	87	88	89	90	91	92	93	94	95
Char	`	a	b	c	d	e	f	g	h	i	j	k	l	m	n	o
Hex	0060	0061	0062	0063	0064	0065	0066	0067	0068	0069	006A	006B	006C	006D	006E	006F
Dec	96	97	98	99	100	101	102	103	104	105	106	107	108	109	110	111
Char	p	q	r	s	t	u	v	w	x	y	z	{	 	}	~	␣
Hex	0070	0071	0072	0073	0074	0075	0076	0077	0078	0079	007A	007B	007C	007D	007E	007F
Dec	112	113	114	115	116	117	118	119	120	121	122	123	124	125	126	127
Char	А	Б	В	Г	Д	Е	Ж	З	И	Й	К	Л	М	Н	О	П
Hex	0080	0081	0082	0083	0084	0085	0086	0087	0088	0089	008A	008B	008C	008D	008E	008F
Dec	128	129	130	131	132	133	134	135	136	137	138	139	140	141	142	143
Char	Р	С	Т	У	Ф	Х	Ц	Ч	Ш	Щ	Ъ	Ы	Ь	Э	Ю	Я
Hex	0090	0091	0092	0093	0094	0095	0096	0097	0098	0099	009A	009B	009C	009D	009E	009F
Dec	144	145	146	147	148	149	150	151	152	153	154	155	156	157	158	159
Char	а	б	в	г	д	е	ж	з	и	й	к	л	м	н	о	п
Hex	00A0	00A1	00A2	00A3	00A4	00A5	00A6	00A7	00A8	00A9	00AA	00AB	00AC	00AD	00AE	00AF
Dec	160	161	162	163	164	165	166	167	168	169	170	171	172	173	174	175
Char					┌	┐	└	┘	┙	┚	┛	├	┤	┥	┦	┧
Hex	00B0	00B1	00B2	00B3	00B4	00B5	00B6	00B7	00B8	00B9	00BA	00BB	00BC	00BD	00BE	00BF
Dec	176	177	178	179	180	181	182	183	184	185	186	187	188	189	190	191
Char	┨	┩	┪	┫	┬	┭	┮	┯	┰	┱	┲	┳	┴	┵	┶	┷
Hex	00C0	00C1	00C2	00C3	00C4	00C5	00C6	00C7	00C8	00C9	00CA	00CB	00CC	00CD	00CE	00CF
Dec	192	193	194	195	196	197	198	199	200	201	202	203	204	205	206	207
Char	┸	┹	┺	┻	┼	┽	┾	┿	┿	┿	┿	┿	┿	┿	┿	┿
Hex	00D0	00D1	00D2	00D3	00D4	00D5	00D6	00D7	00D8	00D9	00DA	00DB	00DC	00DD	00DE	00DF
Dec	208	209	210	211	212	213	214	215	216	217	218	219	220	221	222	223
Char	р	с	т	у	ф	х	ц	ч	ш	щ	ъ	ы	ь	э	ю	я
Hex	00E0	00E1	00E2	00E3	00E4	00E5	00E6	00E7	00E8	00E9	00EA	00EB	00EC	00ED	00EE	00EF
Dec	224	225	226	227	228	229	230	231	232	233	234	235	236	237	238	239
Char	Ё	ё	Є	є	İ	ı	Ÿ	ÿ	°	·	·	√	№	¤	■	NBSP
Hex	00F0	00F1	00F2	00F3	00F4	00F5	00F6	00F7	00F8	00F9	00FA	00FB	00FC	00FD	00FE	00FF
Dec	240	241	242	243	244	245	246	247	248	249	250	251	252	253	254	255

8 CONSUMABLES

The following table shows the list of available consumables for device:

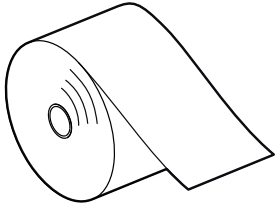
DESCRIPTION	CODE
<p>THERMAL PAPER ROLL</p> <p>weight = 58 g/m² width = 76.2 mm Ø external = 45 mm Ø core = 25 mm</p>	<p>67300000000378</p> 

9 ACCESSORIES

The following table shows the list of available accessories for device:

DESCRIPTION	CODE
BATTERY PACK (For technical specifications, see the paragraph 7.1)	28D3000000005 
BELT CLIP	2140000001225 
SHOULDER BAG	9700000000326 
18W POWER ADAPTER (For technical specifications, see the paragraph 7.1)	963GE02000301 
CAR CHARGER (From 12 Vdc to 24 Vdc (from 250 mA to 500 mA))	966GE02000301 

977CR010000301

DOCKING STATION
1 STATION
(For technical specifications, see the paragraph 7.1)

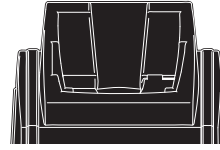

977CR010000300

DOCKING STATION
4 STATION
(For technical specifications, see the paragraph 7.1)

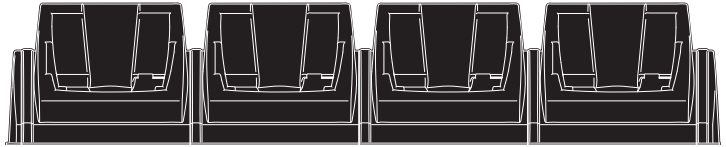

10 ALIGNMENT

The device is provided with a sensor that allows the use of black mark and holes to manage:

- rolls of tickets with pre-printed fields and fixed length
- paper rolls of labels of fixed length

The alignment notch may be formed by:

- black mark printed on paper:(see par. 7.5)
- hole or black mark between a label and subsequent (see par. 7.5)

The alignment sensor assembled on the device is “reflection” sensor: this kind of sensor emits a band of light and detects the quantity of light reflected to it. The presence of the notch is therefore detected by the amount of light that returns to the sensor, considering that the light is reflected by the white paper and absorbed by the black mark.

The following paragraphs show how to correctly set the configuration parameters of device in order to assure the alignment.

10.1 Enable alignment

Device is provided with one fixed sensor for alignment, placed on the upper flat of device.

To guarantee proper alignment is necessary to enable the "Notch Alignment" parameter during the Setup procedure (see Chapter 5)

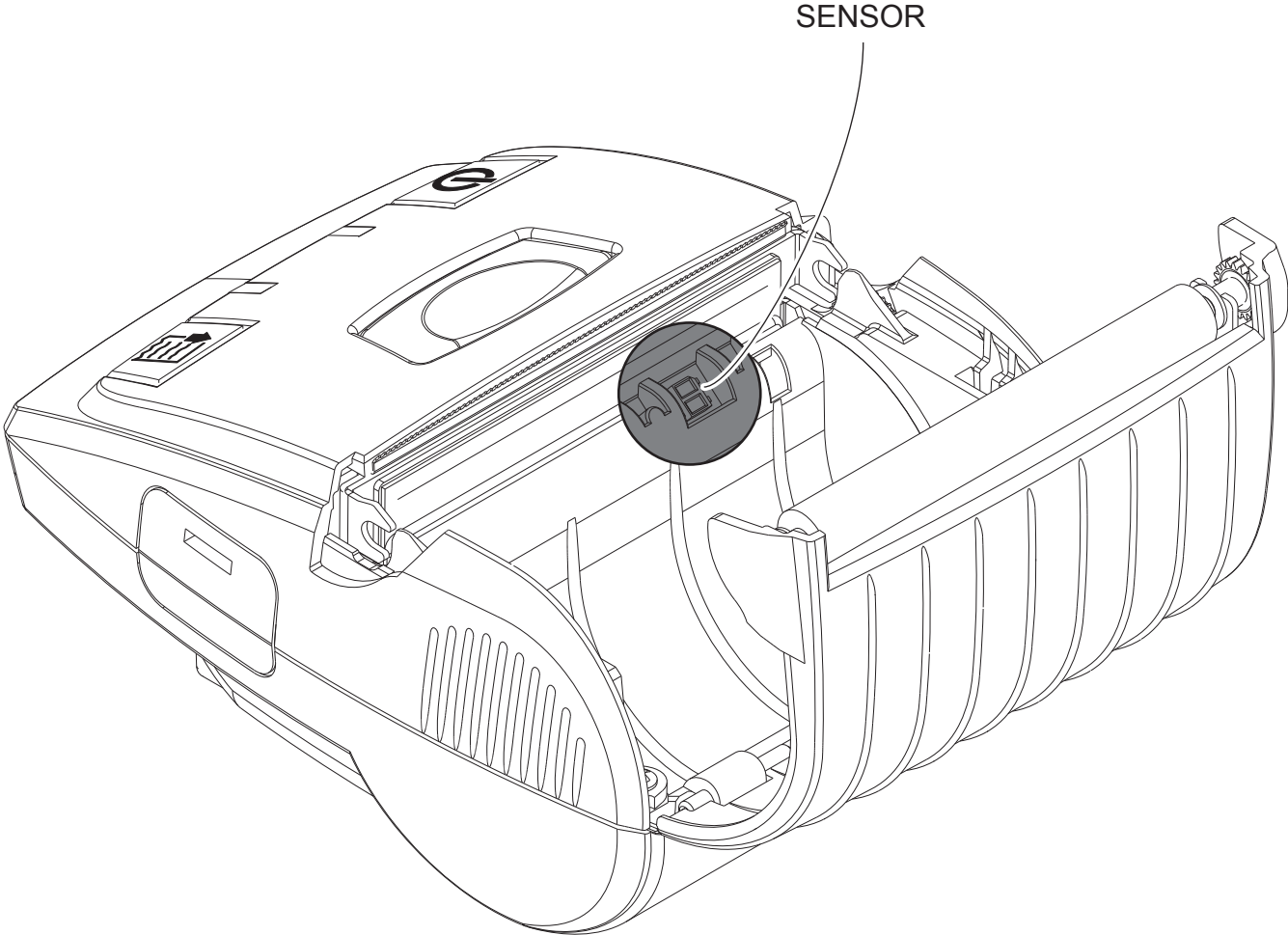

The following image shows the size of paper used and the sensor used for the alignment.

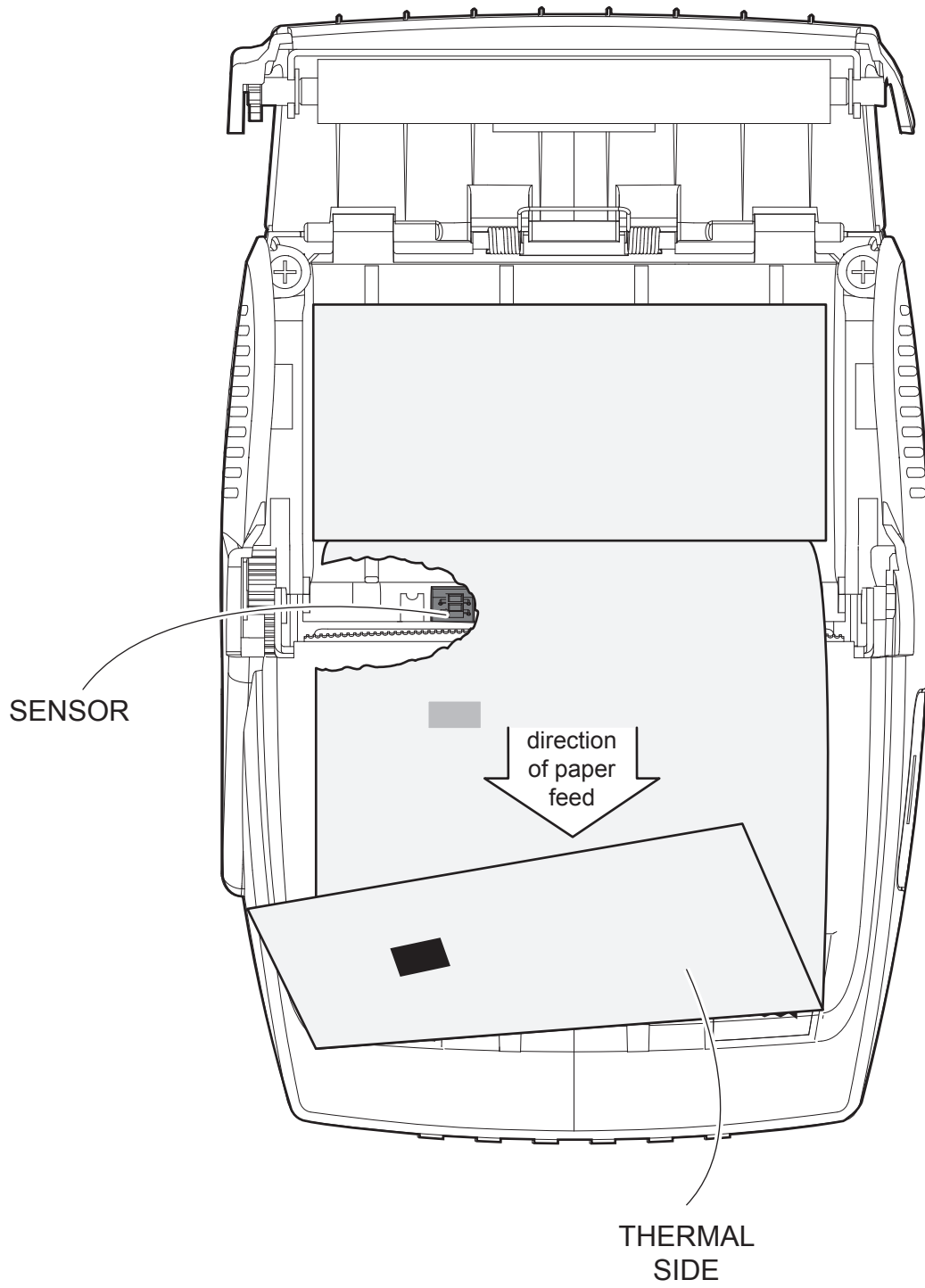

10.2 Alignment parameters

The “alignment point” is defined as the position inside the ticket to use for the notch alignment. The distance between the notch edge and the alignment point is defined as “Notch Distance”.

Referring to the front of the notch, the value of “Notch Distance” value varies from 0mm minimum and 99.9 mm. maximum.

If the “Notch Distance” value is set to 0, the alignment point is set at the beginning of the notch.

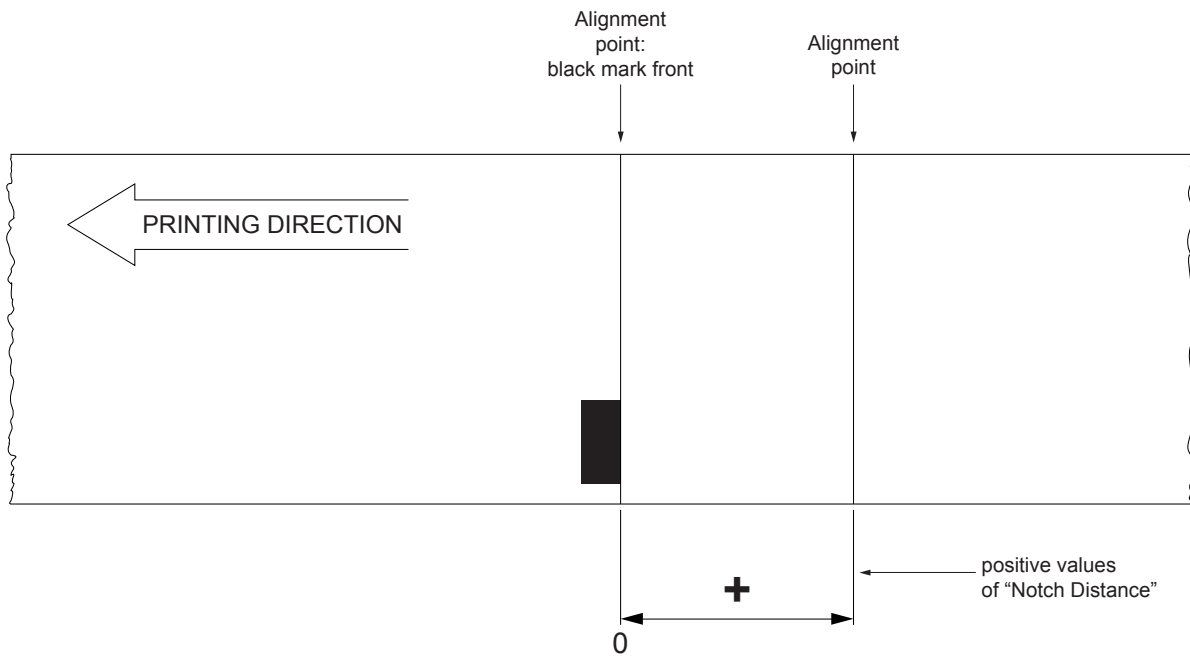

The following figure shows a simplified section of the device with the paper path and the distances (in mm) between the alignment sensor, the print head, serrated blade (cutting line).

NOTE: All the dimensions shown in following figures are in millimetres.

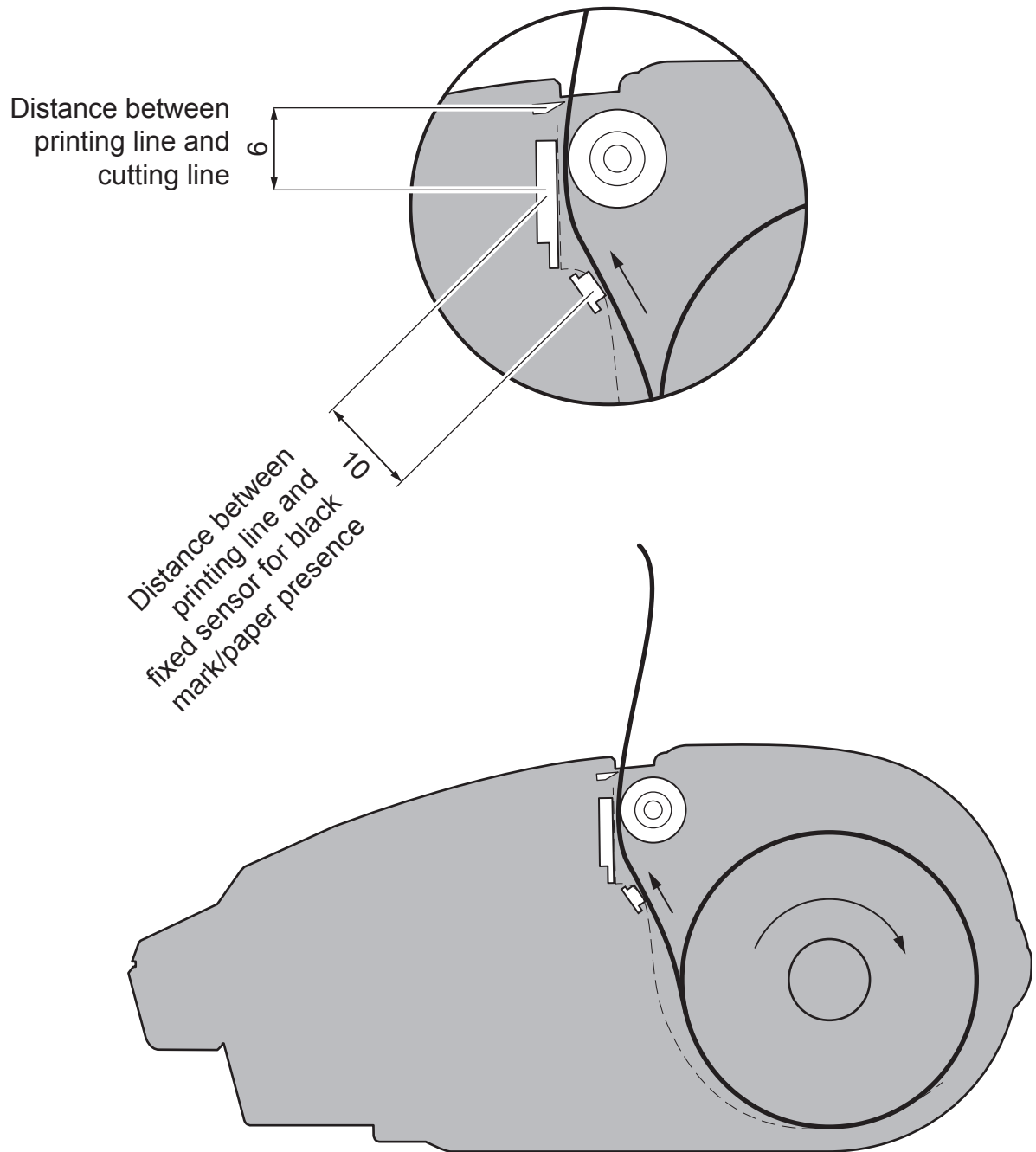

CUSTOM/POS EMULATION

To define the alignment point you need to set the device parameters that compose the numerical value of the “Notch Distance” parameter. (see par.5.4).

For example, to set a notch distance of 15mm between the notch and the alignment point, the parameters must be set on the following values:

Notch Distance [mm x 10] : 1
Notch Distance [mm x 1] : 5
Notch Distance [mm x .1] : 0

The “Notch Distance” parameter, may be modified as follows:

- during the Setup procedure of the device (see chapter 5)
- by driver

10.3 Printing area

In order to print ticket containing only one notch and to not overlay printing to a notch (that will make it useless for the next alignment), it is important to well calibrate the height of the printing area of ticket according to the inter-notch distance

The following figure shows an example of tickets

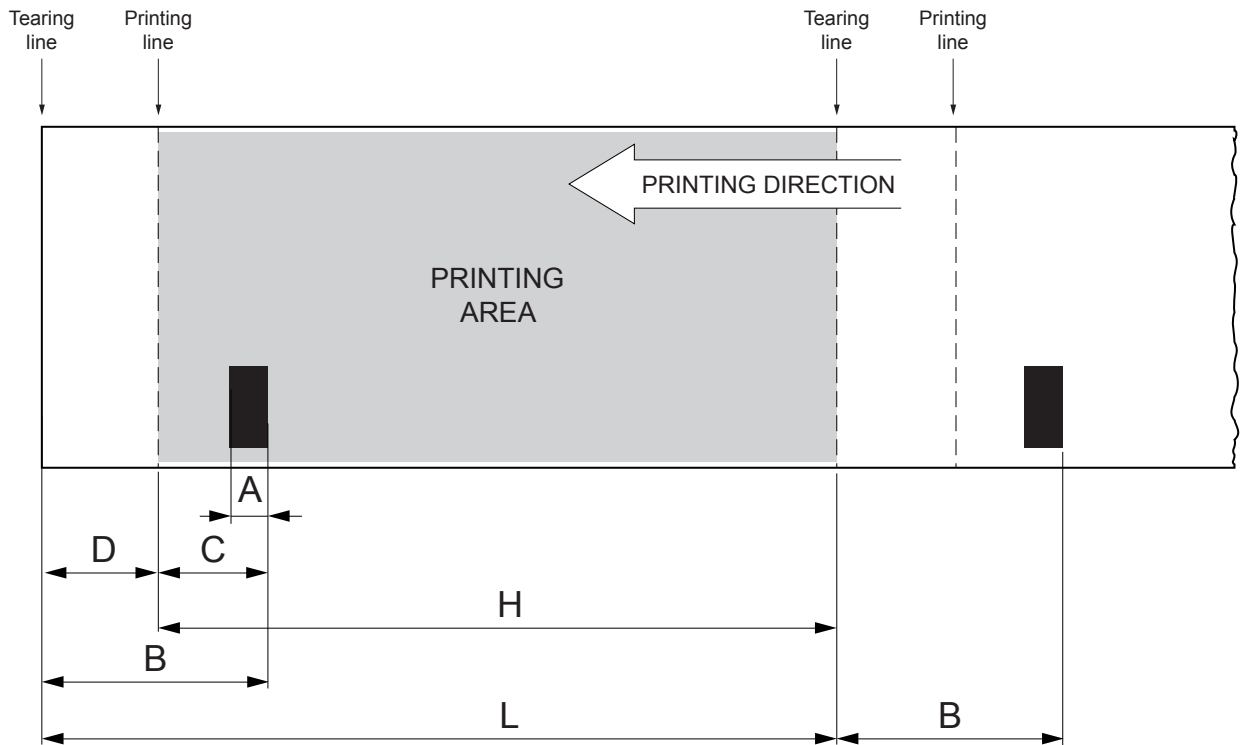

- A "width black mark" = 4÷12 mm
- B "Distance between black mark front/Tearing line" = 19 mm (fixed distance)
- C "Distance between black mark front/Printing line" = 10 mm (fixed distance)
- D "Distance between Printing line/Tearing line" = 9 mm (fixed distance)
- H Distance between the first and the last print line, called "Height of the printing area"
- L Ticket length.

To use all the notches on the card, you must comply with the following equation::

$$H + D \leq L$$

11 TROUBLESHOOTING GUIDE

TROUBLE	PAGE
DEVICE DOES NOT TURN ON	
Briefly press the ON / OFF. The status LED flashes green.	15
Recharge the battery and retry.	32-33
Disconnect the battery pack and reconnect.	34
Replace the battery pack.	34
PAPER DOES NOT FEED	
Check that the paper roll follows the rotation direction indicated and be sure the paper compartment cover is correctly closed.	37
Clean the rubber roller	48
Recharge the battery and retry.	34
WRONG SIGNAL OF PAPER END	
Check that the paper roll follows the rotation direction indicated.	37
If the parameter 'Notch alignment' is enabled, but using paper without notch, the printer is unable to recognize the end of the paper. Disable the parameter.	42
If the parameter 'Notch alignment' is disabled, but using paper with black mark, the device may recognize the black mark as the end of the paper. Enable parameter.	42
POOR PRINT	
Check the paper specifications.	54
Set the parameter 'Print Density' with a higher value. To print labels set the parameter 'Print Density' with value 'Label'.	43

TROUBLE	PAGE
Set in the parameter 'Speed / quality' the 'normal' value.	42
Clean print head	49
Recharge the battery and retry to device.	32 - 33
Replace the battery pack.	34

COMMUNICATION ERROR

If you use the USB port, verify that the connection is correct.	19
If you are using Bluetooth® technology, verify the Bluetooth® setting on the device.	41
Turn the device off and on again.	31
Recharge the battery and retry.	32-33
Enter the Hexadecimal Dump mode and send a command.	44

12 TECHNICAL SERVICE

In case of failure, send the 4 pieces of information listed below to our support team:

1. Product code
2. Serial number
3. Hardware release
4. Firmware release

To get the necessary data, proceed as follows:

1



XXXXXXXXXXXXXXXXXX Rx
00000000000000000000

Write down the data printed on the product label
(see previous paragraphs).

2

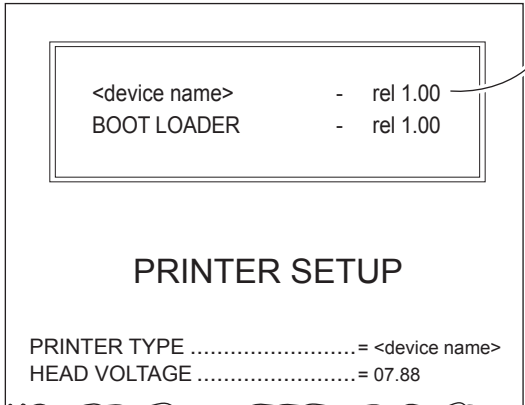

<device name> - rel 1.00
BOOT LOADER - rel 1.00

PRINTER SETUP

PRINTER TYPE = <device name>
HEAD VOLTAGE = 07.88

Print a Setup report (see paragraph 5.1)
The Setup report shows
the firmware release.

3



↓

Customer Service Department:

support@custom.it
(worldwide)

or

support@customamerica.com
(specific for North/South American customers)

Send an e-mail to the Technical Service,
with the data collected.

CUSTOM[®]

CUSTOM S.p.A.

World Headquarters

Via Berettine, 2/B - 43010 Fontevivo, Parma ITALY

Tel. +39 0521 680111 - Fax +39 0521 610701

info@custom.biz - www.custom.biz

All rights reserved