



## S300-PR...B

Polarised retroreflex



## S300-PR...C

Diffuse proximity

### INSTRUCTION MANUAL

#### CONTROLS

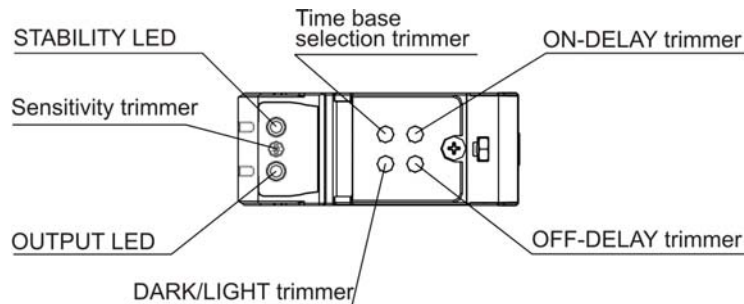

**OUTPUT LED (yellow)**  
The yellow LED ON indicates the output status.

**STABILITY LED (green)**  
The green LED ON indicates that the sensor has working with a enough safety margin.

**SENSITIVITY TRIMMER**  
A mono-turn trimmer adjusts the sensitivity and the sensor operating distance. The operating distance increases, rotating the screws in a clockwise direction.

**DARK/LIGHT TRIMMER**  
A mono-turn trimmer to select dark/light mode.

**ON-DELAY AND OFF-DELAY TRIMMER (only versions with timing functions)**  
Mono-turn trimmers to setting output activation and disactivation delay time. Please refer to "TIMING FUNCTIONS" paragraph for procedure indications.

**TIME BASE SELECTION AND ONE-SHOT TRIMMER (only versions with timing functions)**  
A mono-turn trimmer with three operation position: it allows to select two different delay time base (SHORT BASE and LONG BASE) or ONE SHOT. Please refer to "TIMING FUNCTIONS" paragraph for procedure indications.

**WARNING:** the maximum mechanical rotation range of the trimmer is 240°. Do not force over of the maximum and minimum positions.

#### INSTALLATION

The sensor can be positioned by means of the two housing holes using two screws (M5x35 or longer, 1.2Nm maximum tightening torque). The sensor bottom surface has been provided of two mechanical threaded insert M5x5,5. These metal insert are commercial components.

Various orientable fixing brackets to ease the sensor positioning are available (please refer to the accessories listed in the general catalogue). The operating distance is measured from the front surface of the sensor optics.

For a correct use, the sensor must be installed orthogonal respect the direction of the object to detect like show in the figure.

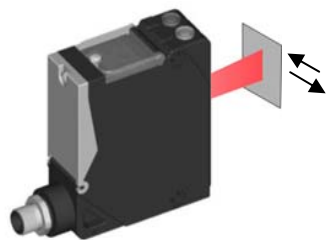

Tighten all screws surely to maintain the water-proof characteristics for IP67 (IEC/EN60529). Excessive tightening causes damage. Tighten the screws within the tightening torque range shown in the table.

TIGHTENING TORQUE (Nm)	
Terminal screws(6pc)	0.5 max
Covers screws	0.5...0.8

The cable gland assure mechanical retention compliant with EN50262.

CABLE DIAMETER	LOAD (N)
4,5..8mm	30
8..10mm	42

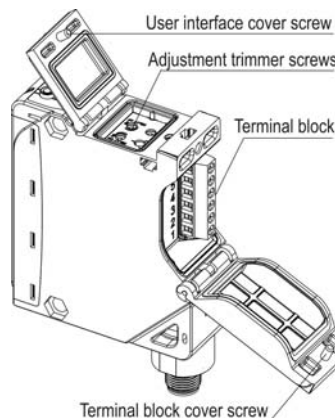

#### TECHNICAL DATA

AC MODELS	S300-PR-1-B/C	DC MODELS	S300-PR-2/5-B/C
Power supply:	24...240 VAC / 24...60 VDC	Power supply:	10...30 VDC Class 2 (UL508)
Ripple:	10 % max	Ripple:	10 % max
Current consumption (output current excluded):	< 3 VA	Current consumption (output current excluded):	< 30 mA
Outputs:	Electromechanical SPDT: 250 VAC, 30 VDC	Outputs:	PNP / NPN open collector R_pull-up/down = 47KΩ
Output current:	Max 3 A (resistive load)	Output current:	100 mA (resistive load)
Response time:	20 ms	Output saturation voltage:	2.4 V max
Switching frequency:	25 Hz	Diagnostic functions:	PNP ALARM output / Test+ input
Weight:	150 g	Response time:	1 ms
AtEx 2014/34/EU:	II 3G EX nA II T6 ; II 3D EX tD A22 IP67 T85°C	Switching frequency:	500 Hz
		Weight:	140 g
		AtEx 2014/34/EU:	II 3G EX nA II T6 ; II 3D EX tD A22 IP67 T85°C

Common data	S300 B	S300 C
Emission type:	RED LED (660nm)	INFRARED LED (880nm)
Operating distance (typical value):	20m (EG2), 22m (EG1) on R5 reflector	3,5m on 90% white target (EG2), 5M (EG1)
Indicators:	OUTPUT LED (YELLOW), STABILITY LED (GREEN)	
Adjustment:	Sensitivity trimmer / DARK/LIGHT trimmer Versions with timing functions: time base selection and one shot trimmer / ON DELAY trimmer / OFF DELAY trimmer	
Time base (Versions with timing functions):	SHORT BASE: 0..2 sec, LONG BASE: 0..10 sec	
Operating temperature:	-40...55 °C	
Storage temperature:	-40...70 °C	
Dielectric strength:	□ 1500 VAC, 1 min between electronics and housing	
Insulating resistance:	> 20 MΩ, □ 500 VDC between electronics and housing	
Ambient light rejection:	EN 60947-5-2	
Vibration:	0.5 mm amplitude, 10 ... 55 Hz frequency, for every axis (EN60068-2-6)	
Shock resistance:	11 ms (30 G) 6 shock for every axis (EN60068-2-27)	
Housing:	PBT 30% Glass fiber-reinforced	
Lenses:	frontal window and lens in PC	
Protection class:	IP67 (IEC / EN60529) / cable gland EN50262	
UL requirements:	60-70°C copper conductor 24-20 AWG; TYPE 1 ENCLOSURE	
Connections:	see the "CONNECTIONS" paragraph	

#### CONNECTIONS

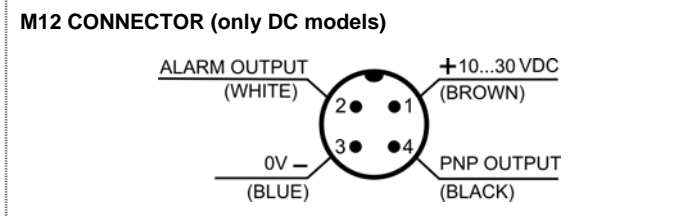
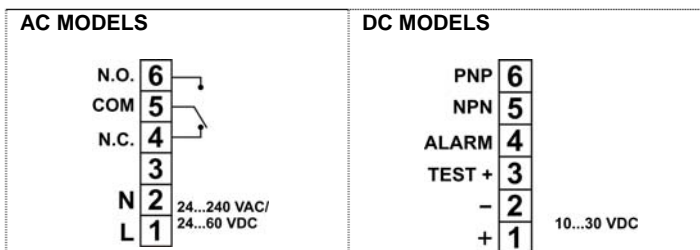

**Terminal block versions (S300-PR-1/2)**  
Use a cable of 4,5 to 10 mm in diameter to ensure water- and dust-proof characteristics. The trasversal section of the cable must be between 16 and 26AWG. The length of conductor peel must be 6mm and the cable peel must be 100mm.

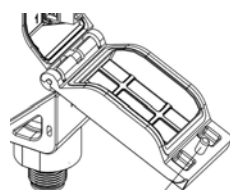

To favour the cable connection it is possible remove (and then replace) the terminal block cover when it is in the maximum opening position (like showed in the figure). Turn off the power supply before wiring. Connect correctly to prevent damage. At the end of the connections, screw the cable gland decisively to lock the cable. Close the terminal block cover with the screw.

**M12 connector versions (S300-PR-5)**  
The connector wires are just connected like show in the previous figure. It is possible change the wiring and use other functionality (NPN output, TEST+ input).

#### SETTING

**Sensitivity setting (S300..B)**  
Position the sensor and reflector on opposite sides. Turn the sensitivity trimmer to maximum. Find the points where the yellow LED (OUT) is switched ON and OFF in both vertical and horizontal positions, and fix the sensor in the centre between these points. Optimum operation is obtained when both LEDs switch ON. If necessary, reduce sensitivity using the trimmer, in order to detect very small targets. In order to improve alignment, repeat the procedure detailed above whilst progressively reducing the sensitivity.

**Sensitivity setting (S300..C)**  
Position the sensor and turn the sensitivity trimmer at minimum: the yellow LED is OFF (litgh mode). Place the target opposite the sensor. Turn the sensitivity trimmer clockwise until the yellow LED turns ON (Target detected state, pos.A). Remove the target, the yellow LED turns OFF. Turn the trimmer clockwise until the yellow LED turns ON (Background detected state, pos.B). The trimmer reaches maximum if the background is not detected. Turn the trimmer in intermediate position C, between the two positions A and B. The green LED must be ON.

#### DIAGNOSTIC FUNCTIONS

S300 has the following diagnostic functions to verify the correct operation on application.

**TEST+ input (only S300-PR-2/5)**  
The TEST+ input can be used to inhibit the emitter and verify that the system is correctly operating. The TEST function is activated if the TEST+ input is connected to a voltage between 10...30V, whereas if the TEST+ input is connected to GND or it is not connected the function is deactivated. Activating the TEST while an object (C)/reflector (B) is in front of the sensor (output ON in light mode), the output switches from ON to OFF, testing the total operation. Activating the TEST whitout an object (C) in front of the sensor (output OFF in light mode), the outpt switches from OFF to ON, testing only the output operation.

**ALARM output (only S300-PR-2/5)**  
The alarm output switches ON whenever the received signals remains without a safety margin (greater than 30% compared to the output switching level). In C model the ALARM output is activated when the sensor detects an object in instability conditions (stability LED OFF, OUT LED ON) for 10 times consecutively. If the commutations number is lower, the count down is reset and restart only in instability condition. The ALARM output remain ON until there is a commutation in stability condition. In B model the ALARM output is activated when the received signal remains without a safety margin for more than 3 seconds.

#### DIMENSIONS

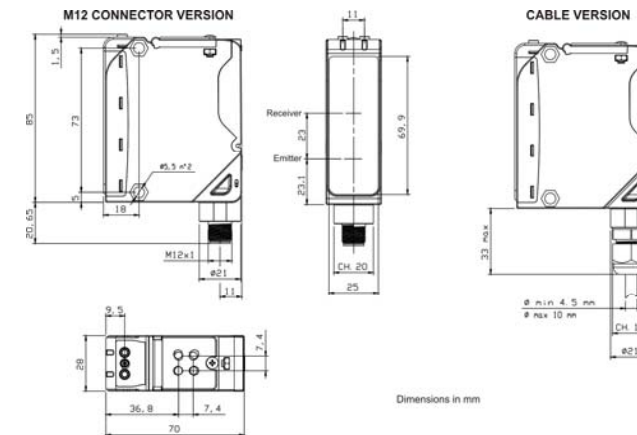

#### TIMING FUNCTIONS

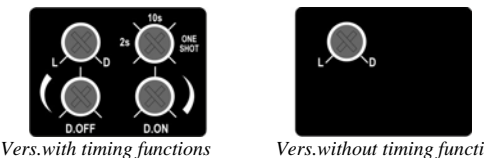

The TIME BASE SELECTION trimmer allows to select the time base or the ONE SHOT function.

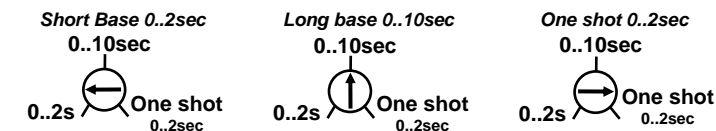

Selecting the short base the time setting of ON delay and OFF delay trimmer is in the range 0..2sec, selecting long base is in the range 0..10sec. To allow a better setting of little delay, the variation of ON and OFF delay are not linear with mechanical regulation of the trimmer: until half rotation the regulation is thinner, whereas from half to full scale the regulation is faster. The follow figure indicates the values of initial, middle and full scale delay of ON and OFF delay trimmer in the two different selectable time base:

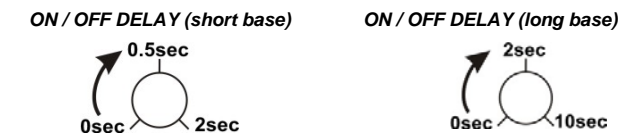

The TIME BASE SELECTION trimmer has a third position to select ONE SHOT mode. The ONE SHOT duration is selectable by ON DELAY trimmer with short time base (0..2 sec). In this mode the OFF delay trimmer is disabled.

#### TIMING DIAGRAM (S300-x-xxxT)

OPERATION MODE	OUTPUT
Normal (timing disable)	[Timing diagram showing output pulses]
ONE SHOT (only with short time base 0..2 sec.)	[Timing diagram showing single pulse]
ON/OFF delay	[Timing diagram showing ON and OFF delays]
ON delay	[Timing diagram showing ON delay]
OFF delay	[Timing diagram showing OFF delay]

The sensors are NOT safety devices, and so MUST NOT be used in the safety control of the machines where installed.

Datalogic S.r.l.  
Via S. Vitalino 13 - 40012 Calderara di Reno - Italy  
Tel: +39 051 3147011 - Fax: +39 051 3147205 - www.datalogic.com

Helpful links at www.datalogic.com: [Contact Us](#), [Terms and Conditions](#), [Support](#).

The warranty period for this product is 36 months. See General Terms and Conditions of Sales for further details.

Under current Italian and European laws, Datalogic is not obliged to take care of product disposal at the end of its life. Datalogic recommends disposing of the product in compliance with local laws or contacting authorised waste collection centres.

© 2009 - 2017 Datalogic S.p.A. and/or its affiliates • ALL RIGHTS RESERVED. • Without limiting the rights under copyright, no part of this documentation may be reproduced, stored in or introduced into a retrieval system, or transmitted in any form or by any means, or for any purpose, without the express written permission of Datalogic S.p.A. and/or its affiliates. Datalogic and the Datalogic logo are registered trademarks of Datalogic S.p.A. in many countries, including the U.S.A. and the E.U. All other trademarks and brands are property of their respective owners. Datalogic reserves the right to make modifications and improvements without prior notification.