



S4300F User Manual

Version 1.0



TABLE OF CONTENTS

1.0 PRODUCT FEATURES	3
2.0 PACKING LIST	3
3.0 THREE-VIEW DRAWING	4
4.0 OPERATING INSTRUCTIONS	5
4.1 Placement Options	5
4.2 Product Structure	6–7
4.3 Operating Instructions	8
5.0 MAINTENANCE	9
6.0 CAUTION	10
6.1 Warning	11
6.2 Note	12
7.0 FAQ	12
8.0 WARRANTY SERVICE	13
8.1 User notice	13

Thank you for your purchase of a **COLORMETRICS** product! Please read the instructions carefully before using it. Note, the images in this manual are only for illustration purposes.

Caution: Please keep children away from parts that might be ingested (like small screws or the plastic bags).

1.0 PRODUCT FEATURES

- Large screen display, high-definition image quality for unparalleled visual enjoyment
- Supports more than 30 multimedia formats
- Powerful editing features, intuitive operation
- Centralized network management, supports real-time updating
- Supports independent software & hardware expansion

2.0 PACKING LIST



Product
(1x)



Keys
(2x2)



Power cord
(1x)



Fuse driver
(1x)

3.0. THREE-VIEW DRAWING

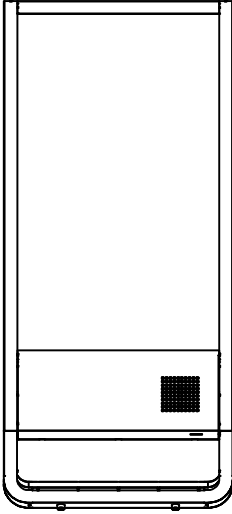

Front view

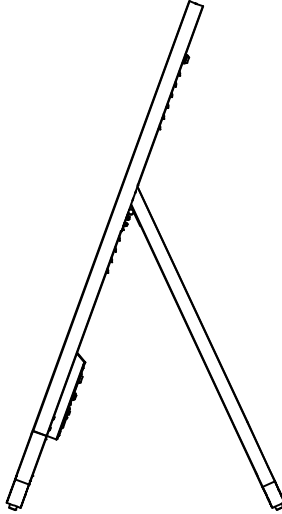

Side view

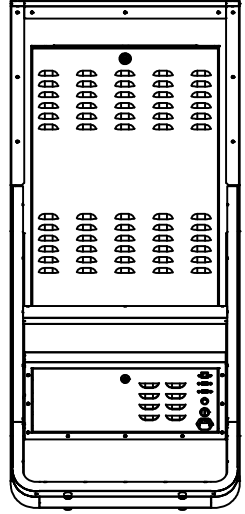

Back view

4.0. OPERATING INSTRUCTIONS

4.1. PLACEMENT OPTIONS

- Free standing

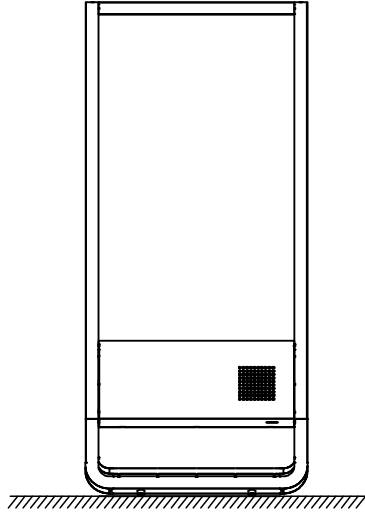

- Supported angle

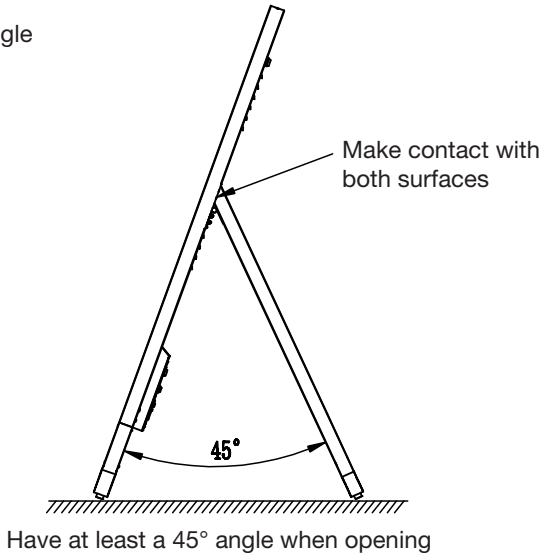

4.0. OPERATING INSTRUCTIONS

4.2. PRODUCT STRUCTURE

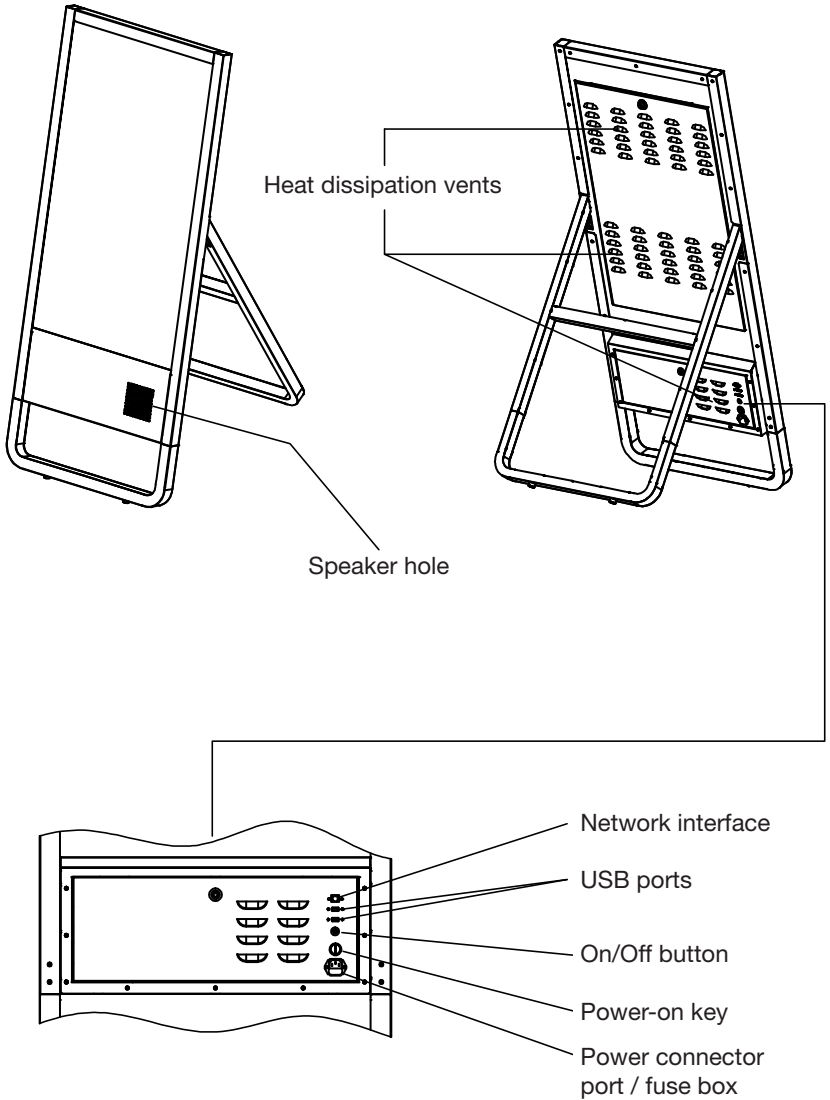

4.0. OPERATING INSTRUCTIONS

4.2. PRODUCT STRUCTURE

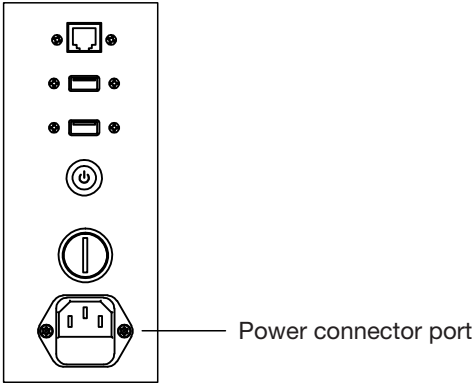

Fuse replacement instructions

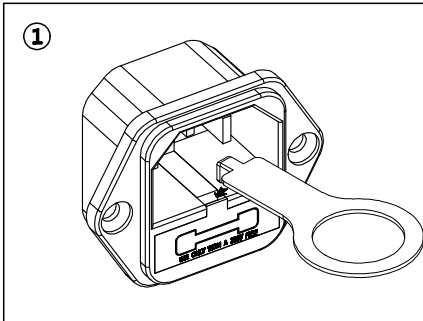

1 Unfasten the fuse box carefully using the fuse driver.

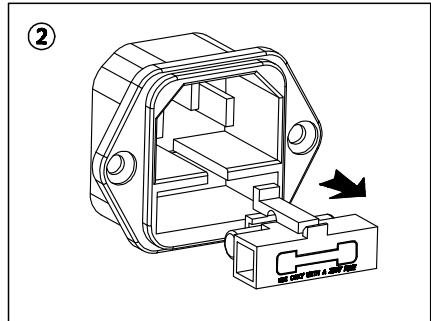

2 Remove the fuse box.

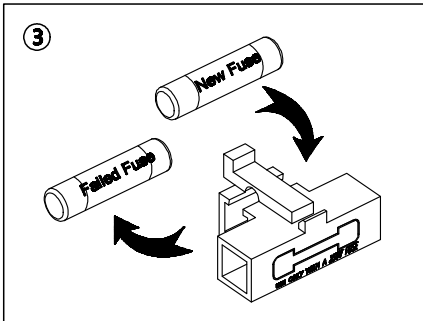

3 Remove the old fuse and replace it with the new fuse.

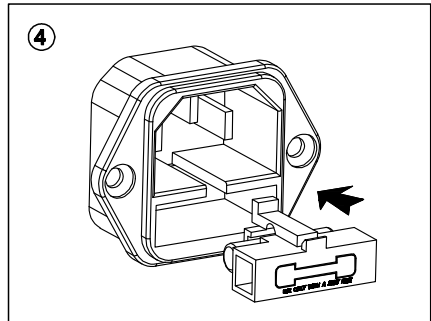

4 Push the fuse box back in and fasten it firmly.

4.0. OPERATING INSTRUCTIONS

4.3. OPERATING INSTRUCTIONS

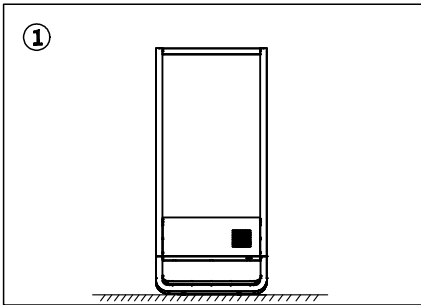

Place the device at the desired location

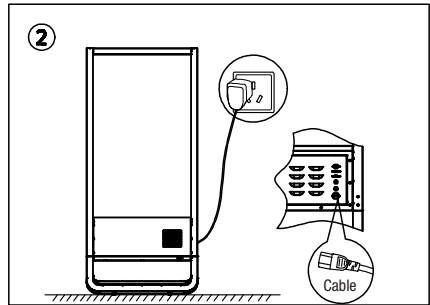

Connect the power cord and the internet cable

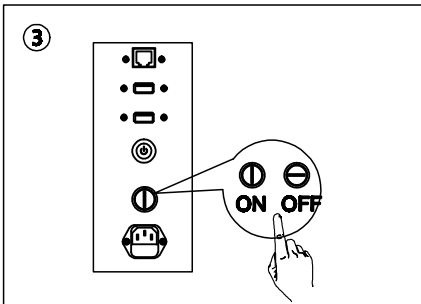

Turn the main power switch to the vertical position to connect the power

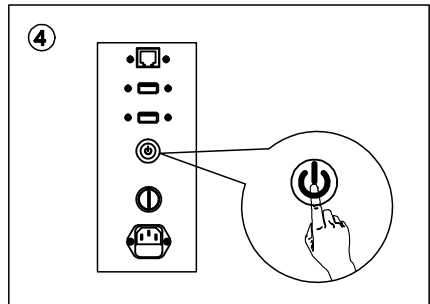

Press the on/off button to boot

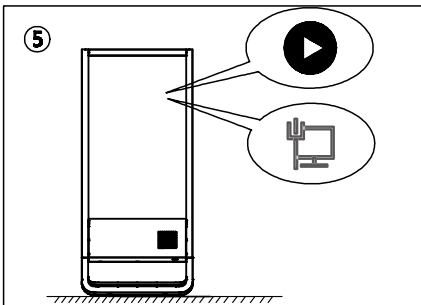

Install the multimedia player software, then set the network parameters. Mark: Support timer switch, remote shutdown and wake on LAN.

5.0. MAINTENANCE



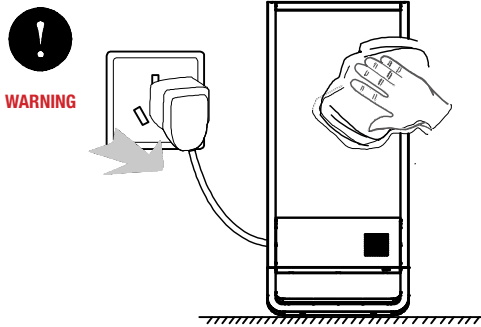







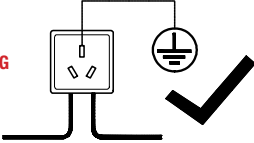

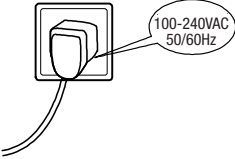

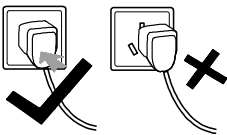
- First unplug the power cord from the outlet.

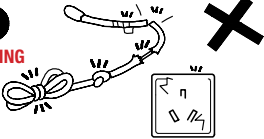

- Always unplug the device before cleaning (there is a danger of electric shock when cleaning a live device).
- Routine servicing: use a soft cloth to clean the surface. Wipe gently to avoid scratches.
- Stubborn stains: use a soft cloth moistened with water or with a small amount of gentle detergent to clean the surface. After washing, wipe the surface thoroughly with a dry soft cloth.

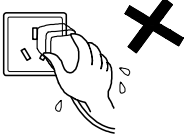

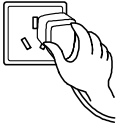
6.0 CAUTION

6.1 WARNING

 WARNING 	 WARNING 
<p>For security reasons and to ensure the product works properly, please make sure the device is properly grounded.</p>	<p>Make sure to use a power supply with 100-240VAC, 50/60Hz.</p>
 WARNING 	 WARNING 
<p>Be sure the plug is fully plugged in. (If it is loose it may cause a fire.)</p>	<p>Ensure that the plug is easy to reach.</p>
 WARNING 	 WARNING 
<p>Avoid excessive winding or stretching, which can damage the power cord, or cause electric shock or fire.</p>	<p>To avoid electric shock, do not touch the power cord or plug with wet hands.</p>
 WARNING 	 WARNING 
<p>Hold the plug firmly on both sides when unplugging.</p>	<p>Do not move the device without first unplugging the power cord.</p>

6.0 CAUTION

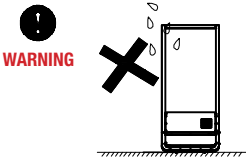
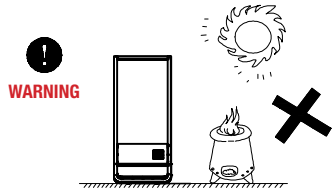
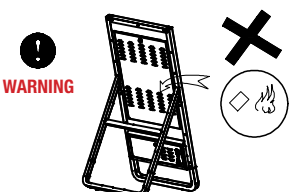
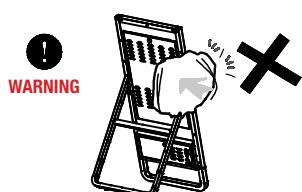
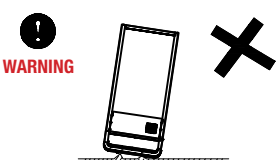
6.1 WARNING

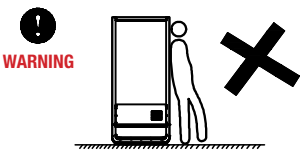
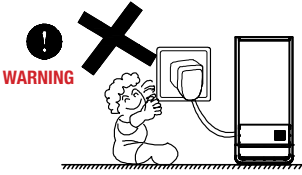
 <p>WARNING</p> <p>Do not drip or splash water on the device, to prevent damage, fire or electric shock.</p>	 <p>WARNING</p> <p>Do not place the device in direct sunlight or near open flames and other heat sources, to prevent fire.</p>
 <p>WARNING</p> <p>Avoid letting foreign objects (especially metal or inflammable materials) fall into the device through the air vents (may cause electric shock or fire).</p>	 <p>WARNING</p> <p>Do not block the vents while powered-on, since this will produce an electric shock or fire due to overheating.</p>
 <p>WARNING</p> <p>Do not place the device at a sloping angle or in an unstable position. (May fall down or tip over.)</p>	 <p>WARNING</p> <p>Do not let non-professionals disassemble the device.</p>
 <p>WARNING</p> <p>Do not lean on the device, to avoid it from falling down.</p>	 <p>WARNING</p> <p>Do not allow children to play around the device, or to touch the device and the power supply.</p>

6.0 CAUTION

6.2 NOTE

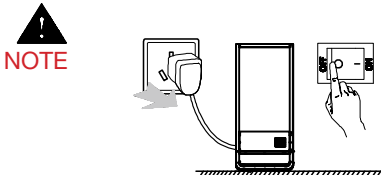
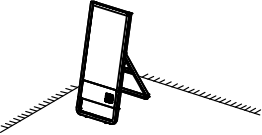
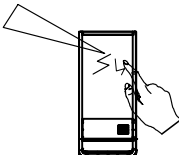
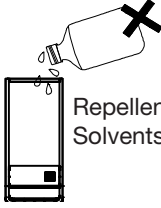
 <p>NOTE</p> <p>If left unused for a long period, please turn off the power or unplug the power cord.</p>	 <p>NOTE</p> <p>Leave proper space all around the device for heat dissipation.</p>
 <p>NOTE</p> <p>Do not knock or scratch the display screen with hard objects or fingernails.</p>	 <p>NOTE</p> <p>Repellents, Solvents...</p> <p>Keep away from insecticides, dissolvent or other volatile liquids to avoid destroying the surface printing.</p>

7.0 FAQ

QUESTIONS	ANSWERS
<p>Cannot start successfully after pressing the on/off button/main power switch</p>	<ul style="list-style-type: none"> • Please make sure there is electricity in the electric socket • Please make sure the power cord is properly connected • Please check the power cord for damage • Please make sure the main power switch is turned on • Please make sure the DC power mode is working (the indicator light is lit when it works properly) • Please make sure the computer motherboard is working (the indicator light is on when it works properly)
<p>No sound is coming from the speakers</p>	<p>Please check whether the PC is in silent mode.</p>
<p>The touch screen does not work properly</p>	<p>Please make sure there is not too much dust or other stains on the screen's surface. Keep it clean for best results.</p>
<p>For other technical issues please contact your local distributor or customer service.</p>	

8.0 WARRANTY SERVICE

The warranty period for the digital signage is 1 year. During the warranty period you will receive a free repair or replacement for damage caused by non-human factors. For damage caused by other factors, or those which occur after the warranty period, you will still benefit from reasonable prices.

The loss/malfunction of the device caused by or due to one of factors below is not within the product maintenance and warranty, and no economical responsibility will be borne:

- Device disassembly by a non-specialized serviceman or a non-specialized engineer.
- Damage caused by fire, electric shock, foreign objects, collapse or natural disasters.

8.1 USER NOTICE

Thank you for choosing our product! This device is guaranteed from the date of sale. If the device breaks or is damaged due to defects in the original materials and manufacturing process within the warranty period, despite having properly followed the instruction sheet, we will offer free repair service according to the conditions of the warranty.

Even within the warranty period, certain maintenance costs will be charged to you in following cases:

1. The damage is caused by incorrect installation which does not meet the device requirements, standards and related specifications;
2. The damage is caused by the installation of accessories which do not meet the device requirements, standards and related specifications;
3. The malfunction and damage is caused by incorrect use, improper storage, or unauthorized disassembly and repair;
4. The damage is caused by natural disasters (such as earthquakes, floods, lightning strikes) or external disasters (such as fires, building collapse);
5. The malfunction or damage is caused by transportation and improper storage during a location change;
6. The warranty period is expired.

ATTENTION

1. In reference to malfunction, a device inspection will determine whether or not the device will be repaired or replaced with a new or equivalent device.
2. For devices that are beyond the warranty period or do not meet the warranty terms, the device will be inspected to determine whether to repair or replace the defective components. Relevant cost of repair and components replacement will be charged depending on the result of the inspection.



Colormetrics GmbH

Braugasse 5, 35390 Gießen, Germany

Phone: +49 (0) 641 580 97601

E-mail: info@colormetrics.info

Online: www.colormetrics.info